

(\*Ganancia Proporcional del PID (-10000 < P < +10000)\*)

TOP

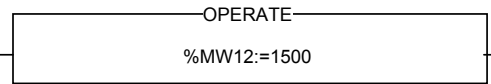

(\*Tiempo Integral del PID ( 0 < Ti < 20000)\*)

TOP+1

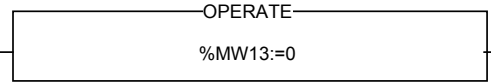

(\*Tiempo derivativo del PID ( 0 < Td < 10000)\*)

TOP+2

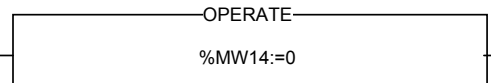

(\*Selector para indicar modo: Manual\*)

TOP+3



(\*Selector para indicar modo: Automático\*)

TOP+4



(\*Bombillo Modo Automático\*)

TOP+5



(\*Bombillo Modo Manual\*)

TOP+6



(\*Asignación valor SP o Salida Manual al cambiar de posición el selector\*)

TOP+7

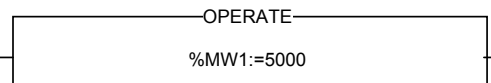

(\*Asignación valor SP o Salida Manual\*)

TOP+8

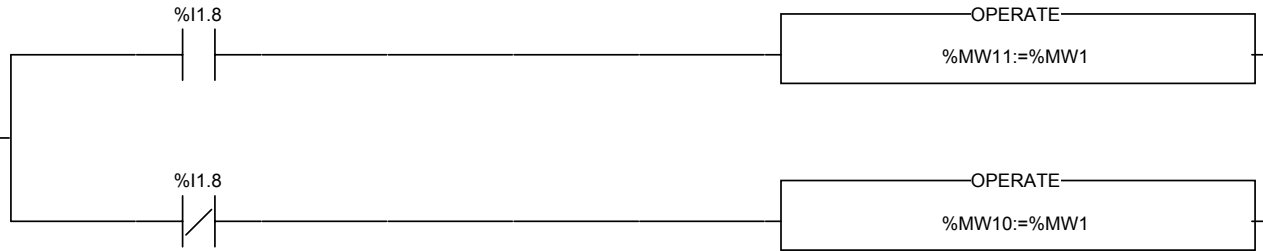

(\*Controlador PID para Lazo de Presión\*)

TOP+9

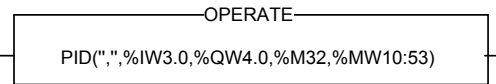

(\*Período de muestreo del PID ( 1 < Ts < 32000 )\*)

TOP+10

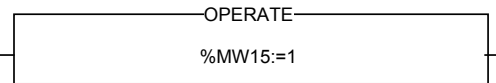

(\*Límite superior del PID en Modo Automático\*)

TOP+11

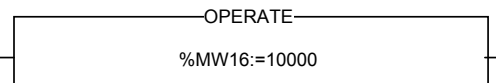

(\*Límite inferior del PID en Modo Automático\*)

TOP+12

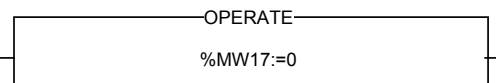

(\*Acción derivada ( 0 = Según medida; 1 = Según desviación )\*)

TOP+13

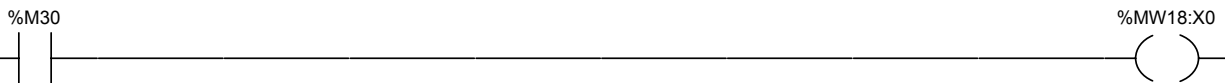

(\*Modo Perturbación ( 0 = Con Perturbación; 1 = Sin Perturbación )\*)

TOP+14

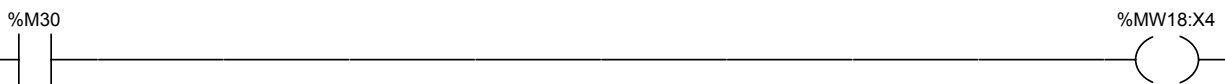

(\*Cónsola CCX17; ( 0 = Con CCX17; 1 = Sin CCX17 )\*)

TOP+15

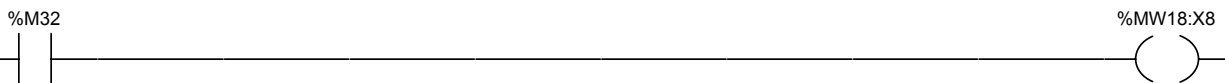

(\*Bombillo para Alarma de Presión Alta\*)

TOP+16

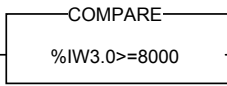

(\*Bombillo para Alarma de Presión Baja\*)

TOP+17

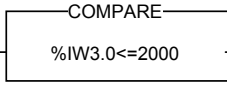

(\*Puesta a ceo de %mw30\*)

TOP+18



(\*Conteo de Unidades\*)

TOP+19

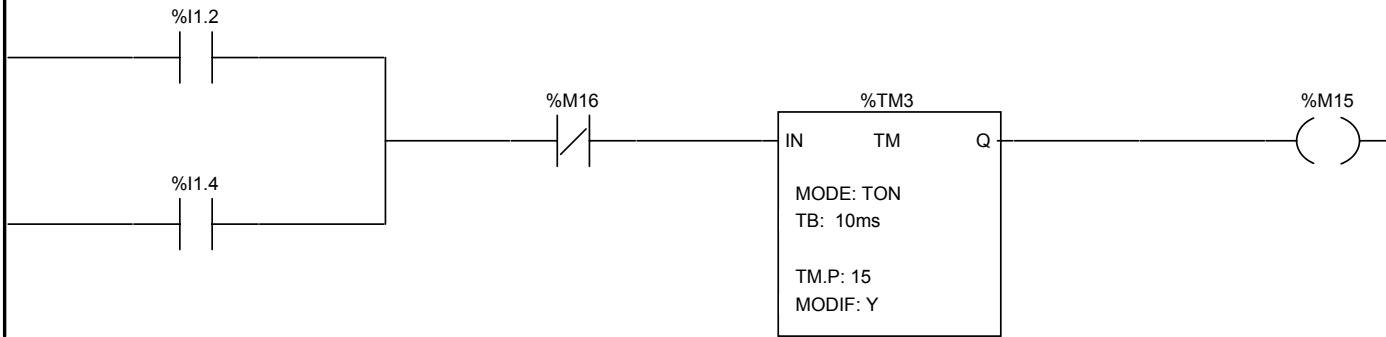

(\*Conteo de Unidades Continuación\*)

TOP+20

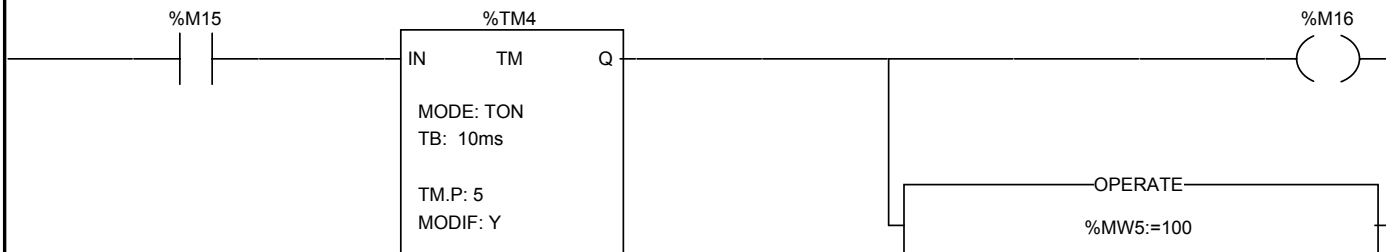

(\*Aumento de SP o S.Manual\*)

TOP+21

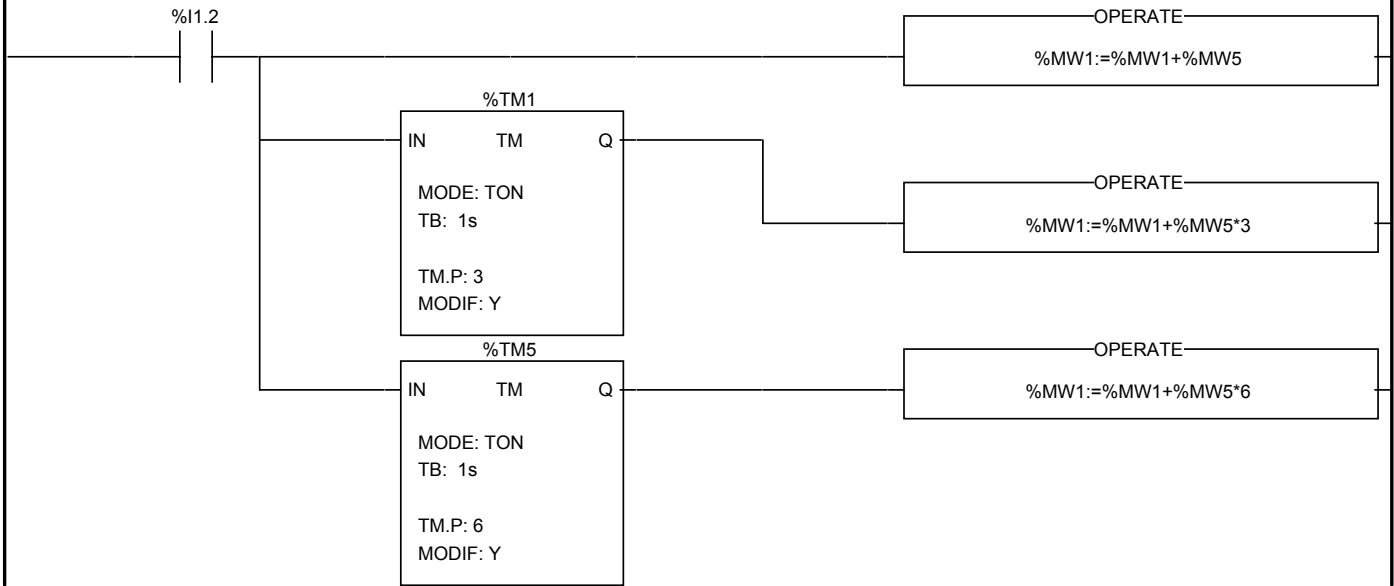

(\*Disminución de SP o S.Manual\*)

TOP+22

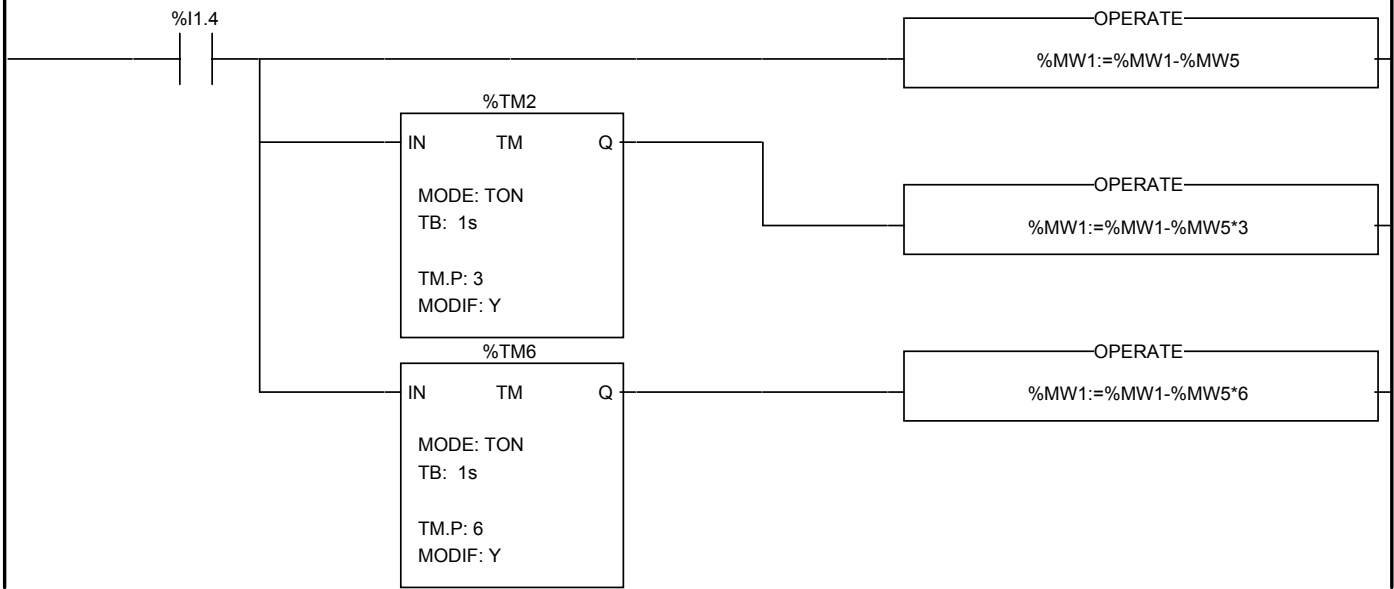

(\*Tope Superior de SP o S. Manual\*)

TOP+23

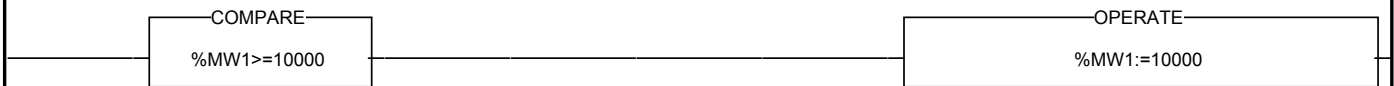

(\*Tope Inferior de SP o S. Manual\*)

TOP+24

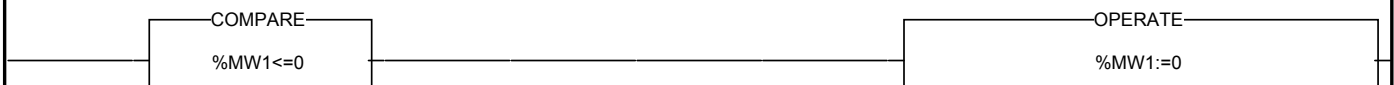

(\*Conversión escala para SP\*)

TOP+25

OPERATE

%MW60:=%MW10/100

(\*Conversión escala para Salida Manual\*)

TOP+26

OPERATE

%MW61:=%MW11/100