

TRABAJO ESPECIAL DE GRADO

DISEÑO EN DETALLE DE UN SISTEMA DE REGENERACIÓN DE REFRIGERANTES DE MEDIANA Y ALTA PRESIÓN

**Presentado ante la ilustre
Universidad Central de Venezuela
por los Brs.
Fariñas P. Elvis E.
Gonzalez R. Juan C.
Para optar al título de
Ingeniero Mecánico**

Caracas, 2001

Fariñas P. Elvis E.,

Gonzalez R. Juan C.,

DISEÑO EN DETALLE DE UN SISTEMA DE REGENERACIÓN DE REFRIGERANTES DE MEDIANA Y ALTA PRESIÓN.

Tutor Académico: Prof. Marcos Gedler. Tutor Industrial: Ing. Ivis Marquina. Tesis. Caracas, U.C.V. Facultad de Ingeniería. Escuela de Ingeniería Mecánica. 2001. 120 pág.

Diseño, sistema, regeneración, refrigerantes, presión.

En el presente trabajo se evaluó el proceso de regeneración de refrigerantes de mediana y alta presión, con este análisis se determinó un proceso más económico y el modo de diseñar un sistema portátil, con productos y equipos existentes en el mercado nacional.

El proceso de regeneración de refrigerantes consiste en la eliminación de los agentes contaminantes tales como partículas sólidas, humedad, aceite lubricante proveniente del compresor de los equipos de refrigeración y aire acondicionado, gases no condensables y ácidos que se producen mediante reacciones químicas entre el agua, el aceite lubricante y el refrigerante. Todos estos agentes contaminantes disminuyen la capacidad intercambio de calor del refrigerante y disminuyen el rendimiento de los sistemas de refrigeración y aire acondicionado, reduciendo el periodo de vida útil de dichos sistemas.

Esta regeneración se lleva a cabo mediante un proceso de destilación de la mezcla, el cual aprovecha las diferentes volatilidades de sus componentes. Mediante un proceso de calentamiento se separa el componente más volátil (el refrigerante), que luego es recuperado mediante su condensación. Antes y después del proceso de destilación la mezcla pasa a través de filtros que se encargan de eliminar posibles trazas remanentes de agentes contaminantes.

En el diseño del sistema de regeneración se analizaron las propiedades de los refrigerantes de trabajo, con estos parámetros se procedió al diseño de la cámara de destilación cálculo y selección de tuberías, compresor, condensador y selección de accesorios (válvulas, visores de líquido, filtros).

Para el proceso de destilación se determinó que el método más económico y funcional era la utilización de resistencias eléctricas como fuente de generación del calor necesario para la evaporación del refrigerante.

Los resultados obtenidos muestran que el uso de una tecnología sencilla, con productos de fácil adquisición en el país y con un costo muy por debajo de la tecnología extranjera se logra un buen término del proceso de regeneración de refrigerantes.

TRABAJO ESPECIAL DE GRADO

DISEÑO EN DETALLE DE UN SISTEMA DE REGENERACIÓN DE REFRIGERANTES DE MEDIANA Y ALTA PRESIÓN

**Presentado ante la ilustre
Universidad Central de Venezuela
por los Brs.
Fariñas P. Elvis E.
Gonzalez R. Juan C.
para optar al título de
Ingeniero Mecánico**

Tutor Académico: Prof. Marcos Gedler
Tutor Industrial: Ing. Ivis Marquina

Caracas, 2001

INDICE

	Pág.
INTRODUCCIÓN	1
CAPITULO 1. EL PROBLEMA	5
<i>Objetivo General</i>	5
<i>Objetivos Específicos</i>	5
CAPITULO 2. MARCO TEORICO	7
2.1 <i>Refrigerantes</i>	7
2.1.1 <i>Requerimientos de los refrigerantes</i>	7
2.1.2 <i>Características Generales</i>	7
2.1.3 <i>Clasificación según su composición</i>	10
2.1.4 <i>Efecto de los refrigerantes sobre los materiales de construcción</i>	12
2.1.5 <i>Factores que disminuyen la eficiencia de los refrigerantes</i>	13
2.1.6 <i>Norma ARI 700</i>	16
2.2 <i>Sistema de Regeneración de Refrigerantes</i>	19
2.2.1 <i>Regeneración</i>	16
2.2.2 <i>Métodos de Regeneración</i>	19
2.2.2.1 <i>Destilación</i>	19
2.2.2.2 <i>Segregación</i>	20
2.2.2.3 <i>Ebullición</i>	20
2.3 <i>Equipos que conforman el Sistema de Regeneración de Refrigerantes</i>	23
2.3.1 <i>Cámara de Destilación</i>	23
2.3.2 <i>Compresor</i>	23
2.3.3 <i>Condensador</i>	24
2.3.4 <i>Válvulas</i>	24
2.3.5 <i>Tuberías</i>	25
2.3.6 <i>Filtros</i>	26
CAPITULO 3. DEFINICIÓN DE PARÁMETROS DE DISEÑO	27
3.1 <i>Norma ARI 740</i>	27
3.2 <i>Parámetros de Diseño</i>	27
3.2.1 <i>Descripción del Proceso de Regeneración</i>	28
3.2.2 <i>Condiciones de la Cámara de Destilación</i>	29
3.2.3 <i>Criterio de selección de la Válvula de Expansión</i>	29
3.2.4 <i>Criterio de selección del Condensador</i>	30
3.2.5 <i>Criterio de selección del Compresor</i>	30
CAPITULO 4. DISEÑO Y SELECCIÓN DE EQUIPOS	33
4.1 <i>Cámara de Destilación</i>	33
4.1.1 <i>Balance Energético</i>	35
4.1.2 <i>Cálculo del Volumen</i>	39
4.1.3 <i>Cálculo del espesor de pared y selección del material</i>	42
4.1.4 <i>Cálculo de las silletas</i>	47
4.1.5 <i>Selección de accesorios de la Cámara de Destilación</i>	50

	Pág.
4.2 Compresor	50
4.3 Condensador	61
4.4 Estructura	64
CAPITULO 5. CALCULO DE TUBERÍAS Y SELECCIÓN DE ACCESORIOS	65
5.1 Líneas de Refrigerante	65
5.2 Dimensionamiento de la línea de liquido entre el recipiente contenedor y la cámara de destilación	67
5.3 Dimensionamiento de la línea de succión	70
5.4 Dimensionamiento de la línea de descarga	72
5.5 Válvulas	74
5.5.1 Selección de la válvula para el control de flujo hacia la Cámara de Destilación	74
5.5.2 Selección de la válvula solenoide	75
5.5.3 Selección de la válvula check	75
5.6 Filtro separadores de aceite	76
5.7 Filtros Secadores	76
5.8 Visores de liquido	77
CAPITULO 6. ESTRATEGIAS DE CONTROL Y AUTOMATIZACIÓN DEL SISTEMA	78
6.1 Sistema básico de control	78
6.2 Lógica de Funcionamiento	78
6.3 Selección de los dispositivos de control	79
6.3.1 Para las resistencias eléctricas	80
6.3.2 Para el motor	81
6.4 Selección de conductores	82
6.5 Selección del PLC	82
6.4 Diagrama de control del Sistema	83
CAPITULO 7. ANÁLISIS ECONÓMICO DEL SISTEMA	85
7.1 Comparación cualitativa entre el Sistema de Regeneración existente en el país y el Sistema diseñado	85
CAPITULO 8. MANUAL DE FUNCIONAMIENTO	87
8.1 Procedimiento de inicio del Proceso de Regeneración	87
8.2 Mantenimiento de la Unidad	88
8.3 Medidas de Seguridad	88
CAPITULO 9. CONCLUSIONES	89
CAPITULO 10. RECOMENDACIONES	90
BIBLIOGRAFÍA	91
ANEXOS	92
Apéndice N° 1. OZONO	93
Apéndice N° 2. CATALOGOS	105
Apéndice N° 3. PLANOS	

LISTA DE FIGURAS Y TABLAS

a.- LISTA DE FIGURAS

<i>Nº</i>	<i>Nombre</i>
1	Flujograma del Proceso de Regeneración
2	Eficiencias aproximadas del compresor para R22 y R12
3	Condiciones termodinámicas de la Cámara de Destilación
4	Diagrama Unifilar de la disposición de los equipos del Proceso de Regeneración
5	Diagrama eléctrico del sistema
6	Localización de la Capa de Ozono
7	Distribución de Energía Solar
8	Secuencia esquemática de la destrucción del ozono por el cloro activo liberado desde una molécula de CFC12
9	Melanoma producto por los rayos ultravioletas
10	Relación entre los Potenciales de Agotamiento del Ozono y el Calentamiento Global

b.- LISTA DE TABLAS

<i>Nº</i>	<i>Nombre</i>
1	Designación normalizada de los refrigerantes
2	Niveles máximos de contaminantes en los refrigerantes
3	Propiedades físicas de los refrigerantes Fluorocarbónicos
4	Capacidades del compresor Bitzer
5	Capacidades del compresor Bock
6	Relación entre las capacidades de los compresores Bock y Bitzer
7	Secciones de Bandas en V normalizadas
8	Circunferencias internas en Bandas V normalizadas
9	Conversiones de longitud de banda
10	Líneas de succión, descarga y liquido para refrigerante R22
11	Rango de velocidades en las líneas
12	Caída de presión en las líneas de liquido
13	Caída de presión en la línea de succión
14	Caída de presión de la Válvula termostática
15	Lista de materiales y equipos
16	Categorías de los contactores según su aplicación
17	Valores de Ozono Depletion Potential (ODP)
18	Valores de Global Warming Potential (GWP)

INTRODUCCIÓN.

La destrucción de la capa de ozono es uno de los problemas ambientales más graves que debemos enfrentar hoy en día. Este fenómeno es responsable de millones de casos de cáncer de la piel a escala mundial y de perjudicar la actividad agrícola. Esta problemática a motivado a la comunidad internacional a acordar medidas para protegerse de una amenaza común.

En 1987, los gobiernos de todos los países del mundo acordaron tomar las medidas necesarias para solucionar este grave problema firmando el *PROTOCOLO DE MONTREAL* relativo a las sustancias que agotan la Capa de Ozono. En este se acordó que los países desarrollados tomarían una acción inmediata.

Desde entonces, considerando la inestabilidad de este gas y su vulnerabilidad ante agentes naturales, nuevas pruebas científicas han demostrado que la destrucción del mismo esta ocurriendo más rápido, superando las estimaciones realizadas.

Durante medio siglo, las sustancias químicas más perjudiciales para la capa de ozono fueron consideradas milagrosas, de una utilidad incomparable para la industria y los consumidores e inocuas para los seres humanos y el medio ambiente. Inertes, muy estables, ni inflamables ni venenosas, fáciles de almacenar y de bajo costo de producción, los clorofluorocarbonos (CFC) parecían ideales para el mundo moderno. No sorprende, entonces, que su uso se haya generalizado más y más.

En los últimos años, el uso de varios productos sintéticos ampliamente distribuidos ha sido afectado por un nuevo requisito, llamado protección al ambiente. Las industrias que producen, usan, o consumen estos productos deben reconsiderar su utilización o incluso deben abandonarlos; éste es el caso de los productos CFC y HCFC, ya que ambos influyen en el agotamiento de la capa de ozono y contribuyen con el efecto invernadero.

La mayor parte de los CFC producidos en el mundo se utilizan en refrigeradores, congeladores, acondicionadores de aire, aerosoles y plásticos expansibles, que tienen múltiples usos en la construcción, la industria automotriz y la fabricación de envases.

Por todo lo expuesto anteriormente, los países desarrollados y los países en vía de desarrollo deben mancomunarse para controlar la utilización de estas sustancias destructoras de la capa de ozono, hasta lograr la erradicación total de las mismas.

Aunque todavía existe mucho debate sobre los fenómenos químicos que ocurren en la atmósfera ya que no son entendidos en su totalidad y sus consecuencias, se ha llegado a la decisión de eliminar la producción de los compuestos CFC y HCFC, y los sistemas que utilicen estos refrigerantes deben ser convertidos en sistemas que utilicen otros tipos de refrigerantes no contaminantes. Mientras se produce esa conversión, esos sistemas solo podrán usar refrigerantes CFC y HCFC regenerados mediante máquinas especiales que eliminan sus impurezas. Sin embargo los países en vía de desarrollo no poseen la capacidad de acción, bien sea logística y/o económica de los países desarrollados, para iniciar una campaña para la regeneración de refrigerantes; por lo tanto, considerando el costo que acarrea importar esta tecnología, es imperiosa la necesidad del desarrollo de la misma en el país.

Este trabajo tiene por objeto el diseño de un sistema de regeneración de refrigerantes de mediana y alta presión; el mismo tiene la finalidad de regenerarlos (hacerlos reutilizables); esto se logra mediante la eliminación de las impurezas y agentes contaminantes que puedan generarse en los sistemas de refrigeración y aire acondicionado. De este modo se evita que el refrigerante contaminado sea desechado a la atmósfera. El diseño de este sistema debe ser de fácil manejo, y con un costo relativamente bajo, utilizando equipos existentes en el mercado nacional.

Este proyecto forma parte de los programas de desarrollo de la Naciones Unidas (*UNDP*) que se denomina ***IMPLEMENTACIÓN DE UN PROGRAMA PARA LA RECUPERACIÓN Y REGENERACIÓN DE REFRIGERANTES.***

Una comisión bilateral entre Canadá y Venezuela está brindando soporte técnico y económico al esfuerzo venezolano para la reducción de la emisión de sustancias agotadoras del ozono mediante el establecimiento de centros de regeneración en el país. Estos centros deben suministrar los siguientes servicios:

- Provisión de equipos de regeneración de refrigerantes.

- Provisión de laboratorios analíticos con los equipos apropiados para el análisis y certificación del refrigerante regenerado de acuerdo con las norma ARI 700 o su equivalente ISO.

El ente gubernamental que coordina este trabajo es el Fondo Venezolano de Reconversión Industrial y Tecnológica (FONDOIN). El organismo privado que dirige el centro de regeneración nacional es la Empresa Ingeniería de Gases Refrigerantes y Sistemas, C.A. (INGARSICA). Este centro de regeneración nacional cuenta con un sistema de regeneración que tiene una capacidad de regeneración de 800 Toneladas métricas al año que no satisface la demanda nacional que se estima según cifras de FONDOIN en 10.000 Toneladas métricas al año.

Tomando como base todos estos argumentos, este trabajo representa el primer paso que da Venezuela en el desarrollo de una tecnología propia para complementar la capacidad de regeneración y de esta forma contribuir a controlar la emisión de las sustancias agotadoras del ozono.

Para el diseño de esta maquina se analizaron las propiedades físicas de los refrigerantes de mediana y alta presión. Con estos parámetros se selecciono el método de regeneración más conveniente de acuerdo con los requerimientos del diseño y se procedió al cálculo y selección de los materiales y equipos necesarios para la conclusión satisfactoria del proceso de regeneración de estos refrigerantes.

En el capítulo 1 se plantea el problema y los objetivos generales y específicos de este trabajo.

El capítulo 2 reseña los refrigerantes, su clasificación y sus características, además refiere los métodos de regeneración de los mismos.

En el capítulo 3 se definen los parámetros de diseño de la maquina, se describe el proceso de regeneración y los equipos que conforman el sistema de regeneración.

En los capítulos 4 y 5 se muestran los cálculos efectuados para el diseño y selección de los distintos equipos que conforman el sistema de regeneración, como son, la cámara de destilación, compresor, condensador, tuberías y accesorios.

El capítulo 6 se definen las estrategias de control y automatización del sistema de regeneración de refrigerantes, así como los criterios de selección de los equipos de automatización.

En el capítulo 7 se realiza un análisis comparativo entre regenerar refrigerante, reconvertir los equipos de refrigeración y aire acondicionado existentes o comprar refrigerante nuevo.

El capítulo 8 contiene el manual de funcionamiento de la maquina, además, muestra una guía para el mantenimiento del sistema y medidas de seguridad pertinentes al proceso de regeneración.

Los capítulos 9 y 10 contienen las conclusiones y recomendaciones de este trabajo.

En los anexos esta contemplado un apéndice que reseña el problema de la destrucción de la capa de ozono y como esta se ve afectada por la acción de los gases refrigerantes. El apéndice 2 contempla los catálogos referentes a los equipos seleccionados para el diseño del sistema.

CAPITULO 1. EL PROBLEMA.

Con la paralización de la producción de las sustancias agotadoras de la capa de Ozono, entre estas los refrigerantes CFC y HCFC; la industria se ha visto en la necesidad de crear una tecnología de forma de prolongar la vida útil de la existencia de estos gases, hasta tanto no se halle un sustituto de los mismos.

Con este fin se ha creado el proceso de regeneración. Este proceso tiene por objeto restaurar las propiedades termofísicas de los gases refrigerantes, de manera que puedan ser reutilizados en cualquier sistema de refrigeración o aire acondicionado sin perjudicar o disminuir la vida útil o la eficiencia de los mismos o de sus componentes.

Actualmente Venezuela cuenta con un sistema de regeneración el cual tiene una capacidad de regeneración de 800 toneladas métricas al año. Sin embargo este sistema no satisface el mercado nacional el cual se estima según cifras de FONDOIN en 10.000 toneladas métricas. Otro problema significativo es la ubicación del centro de regeneración, ya que el único que existe en el país se encuentra en la zona industrial de Mampote, por esta razón cualquier refrigerante que necesite ser regenerado independientemente de donde se encuentre tiene que ser trasladado a este centro, lo que acarrea una pérdida de tiempo y de capital.

Por todo esto es necesario la creación de un sistema de regeneración versátil de forma que se puedan crear centros de regeneración en puntos estratégicos del país y de esta forma lograr satisfacer la demanda nacional.

Objetivo General.

Diseñar en detalle un sistema de regeneración de refrigerantes de mediana y alta presión, para los refrigerantes R-12, R-22 y R-134a.

Objetivos Específicos.

- Establecer condiciones de operación para una producción de 400 TM/año.

- Diseñar y/o seleccionar cada uno de los equipos principales que conforman el sistema de regeneración.
- Especificar todas las tuberías y accesorios.
- Diseño de las estrategias de control y selección de cada uno de los accesorios que lo conforman.

CAPITULO 2. MARCO TEORICO.

2.1 Refrigerantes.

2.1.1 Requerimientos de los refrigerantes.

Propiamente no existe un refrigerante ideal y por las grandes diferencias en las condiciones y necesidades de las distintas aplicaciones, no hay un solo refrigerante que sea universalmente adaptable a todas las aplicaciones. El diseño de sistemas y equipos de refrigeración depende en gran medida de las propiedades y características del refrigerante.

El refrigerante debe satisfacer muchos requerimientos, algunos de estos no están directamente relacionados con la propiedad de transferir calor. La característica más importante de un refrigerante es la estabilidad química bajo condiciones de trabajo, otros requerimientos están relacionados con costos, disponibilidad, eficiencia y compatibilidad con el lubricante del compresor y con los materiales que constituyen el sistema. Otra característica importante es el calor latente de vaporización. Las propiedades como conductividad térmica y viscosidad afectan la eficiencia en el intercambio de calor y diseño de tuberías. Se prefiere baja conductividad térmica y baja viscosidad.

2.1.2 Características generales.

Los refrigerantes son el fluido de trabajo en los sistemas de refrigeración y aire acondicionado. Estos se encargan de absorber calor de un recinto y llevarlo a otro o al exterior, todo esto mediante evaporación y condensación respectivamente. Estos cambios de fase ocurren en sistemas mecánicos de absorción y compresión de vapor. La búsqueda de un refrigerante completamente seguro, con buenas propiedades térmicas condujo al desarrollo de los refrigerantes fluorocarburos en la última parte de la década de los años 20. Inventados casi por casualidad en 1928, se los usó inicialmente como líquido frigorífico de los refrigeradores. A partir de 1950, fueron usados como gases propulsores en los aerosoles. La revolución informática permitió que se usaran como solventes de gran eficacia, debido a que pueden limpiar los circuitos delicados sin dañar sus bases de plástico.

Estos gases en su mayoría están compuestos por moléculas que poseen átomos de Cloro (Cl), Flúor (F), Hidrógeno (H) y Carbono (C). De estos compuestos el Cloro contribuye con el agotamiento del Ozono y el Carbono con el calentamiento global o efecto invernadero. La tabla N° 1 de muestra la designación normalizada de los refrigerantes así como su formula química según ASHRAE.

Los fluorocarburos (hidrocarburos fluoronados) son un grupo de una familia de compuestos conocidos como halocarburos (hidrocarburos halogenados). La familia de compuestos halocarburos son sintetizados reemplazando uno o más de los átomos de hidrógeno en moléculas de metano (CH_4) o de etano (C_2H_6), los cuales ambos son hidrocarburos puros con átomos de Cloro, Fluor y/o Bromo, siendo el ultimo grupo de la familia de los halógenos. Los halocarburos desarrollados a partir de la molécula de metano son conocidos como “halocarburos de metano” así mismo aquellos desarrollados de la molécula etano son referidos como “halocarburos de la serie del etano”.

TABLA N° 1. Designación Normalizada de los Refrigerantes.

Refrigerant Number	Chemical Name or Composition (% by mass)	Chemical Formula	Refrigerant Number	Chemical Name or Composition (% by mass)	Chemical Formula
Methane Series			Zeotropes (Continued)		
10	tetrachloromethane (carbon tetrachloride)	CCl ₄	403A	R-290/22/218 (5/75/20)	
11	trichlorofluoromethane	CCl ₃ F	403B	R-290/22/218 (5/56/39)	
12	dichlorodifluoromethane	CCl ₂ F ₂	404A	R-125/143a/134a (44/52/4)	
12B1	bromochlorodifluoromethane	CBrClF ₂	405A	R-22/152a/142b/C318 (45/7/5.5/42.5)	
12B2	dibromodifluoromethane	CBr ₂ F ₂	406A	R-22/600a/142b (55/4/41)	
13	chlorotrifluoromethane	CClF ₃	407A	R-32/125/134a (20/40/40)	
13B1	bromotrifluoromethane	CBrF ₃	407B	R-32/125/134a (10/70/20)	
14	tetrafluoromethane (carbon tetrafluoride)	CF ₄	407C	R-32/125/134a (23/25/52)	
20	trichloromethane (chloroform)	CHCl ₃	407D	R-32/125/134a (15/15/70)	
21	dichlorofluoromethane	CHCl ₂ F	408A	R-125/143a/22 (7/46/47)	
22	chlorodifluoromethane	CHClF ₂	409A	R-22/124/142b (60/25/15)	
22B1	bromodifluoromethane	CHBrF ₂	409B	R-22/124/142b (65/25/10)	
23	trifluoromethane	CHF ₃	410A	R-32/125 (50/50)	
30	dichloromethane (methylene chloride)	CH ₂ Cl ₂	410B	R-32/125 (45/55)	
31	chlorofluoromethane	CH ₂ ClF	411A	R-1270/22/152a (1.5/87.5/11.0)	
32	difluoromethane (methylene fluoride)	CH ₂ F ₂	411B	R-1270/22/152a (3/94/3)	
40	chloromethane (methyl chloride)	CH ₃ Cl	412A	R-22/218/142b (70/5/25)	
41	fluoromethane (methyl fluoride)	CH ₃ F	Azeotropic Blends (% by mass)		
50	methane	CH ₄	500	R-12/152a (73.8/26.2)	
Ethane Series			501	R-22/12 (75.0/25.0)*	
110	hexachloroethane	CCl ₃ CCl ₃	502	R-22/115 (48.8/51.2)	
111	pentachlorofluoroethane	CCl ₃ CCl ₂ F	503	R-23/13 (40.1/59.9)	
112	1,1,2,2-tetrachloro-1,2-difluoroethane	CCl ₂ FCCl ₂ F	504	R-32/115 (48.2/51.8)	
112a	1,1,1,2-tetrachloro-2,2-difluoroethane	CCl ₃ CClF ₂	505	R-12/31 (78.0/22.0)*	
113	1,1,2-trichloro-1,2,2-trifluoroethane	CCl ₂ FCClF ₂	506	R-31/114 (55.1/44.9)	
113a	1,1,1-trichloro-2,2,2-trifluoroethane	CCl ₃ CF ₃	507A	R-125/143a (50/50)	
114	1,2-dichloro-1,1,2,2-tetrafluoroethane	CClF ₂ CClF ₂	508A	R-23/116 (39/61)	
114a	1,1-dichloro-1,2,2,2-tetrafluoroethane	CCl ₂ FCF ₃	508B	R-23/116 (46/54)	
114B2	1,2-dibromo-1,1,2,2-tetrafluoroethane	CBrF ₂ CBrF ₂	509A	R-22/218 (44/56)	
115	chloropentafluoroethane	CClF ₂ CF ₃	Miscellaneous Organic Compounds		
116	hexafluoroethane	CF ₃ CF ₃	<i>Hydrocarbons</i>		
120	pentachloroethane	CHCl ₂ CCl ₃	600	butane	CH ₃ CH ₂ CH ₂ CH ₃
123	2,2-dichloro-1,1,1-trifluoroethane	CHCl ₂ CF ₃	600a	2-methyl propane (isobutane)	CH(CH ₃) ₃
123a	1,2-dichloro-1,1,2-trifluoroethane	CHClFCClF ₂	<i>Oxygen Compounds</i>		
124	2-chloro-1,1,1,2-tetrafluoroethane	CHClFCF ₃	610	ethyl ether	C ₂ H ₅ OC ₂ H ₅
124a	1-chloro-1,1,2,2-tetrafluoroethane	CHF ₂ CClF ₂	611	methyl formate	HCOOCH ₃
125	pentafluoroethane	CHF ₂ CF ₃	<i>Sulfur Compounds</i>		
133a	2-chloro-1,1,1-trifluoroethane	CH ₂ ClCF ₃	620	(Reserved for future assignment)	
134a	1,1,1,2-tetrafluoroethane	CH ₂ F ₂ CF ₃	Nitrogen Compounds		
140a	1,1,1-trichloroethane (methyl chloroform)	CH ₃ CCl ₃	630	methyl amine	CH ₃ NH ₂
141b	1,1-dichloro-1-fluoroethane	CCl ₂ FCH ₃	631	ethyl amine	C ₂ H ₅ NH ₂
142b	1-chloro-1,1-difluoroethane	CClF ₂ CH ₃	Inorganic Compounds		
143a	1,1,1-trifluoroethane	CF ₃ CH ₃	702	hydrogen	H ₂
150a	1,1-dichloroethane	CHCl ₂ CH ₃	704	helium	He
152a	1,1-difluoroethane	CHF ₂ CH ₃	717	ammonia	NH ₃
160	chloroethane (ethyl chloride)	CH ₃ CH ₂ Cl	718	water	H ₂ O
170	ethane	CH ₃ CH ₃	720	neon	Ne
Propane Series			728	nitrogen	N ₂
216ca	1,3-dichloro-1,1,2,2,3,3-hexafluoropropane	CClF ₂ CF ₂ CClF ₂	732	oxygen	O ₂
218	octafluoropropane	CF ₃ CF ₂ CF ₃	740	argon	Ar
245cb	1,1,1,2,2-pentafluoropropane	CF ₃ CF ₂ CH ₃	744	carbon dioxide	CO ₂
290	propane	CH ₃ CH ₂ CH ₃	744A	nitrous oxide	N ₂ O
Cyclic Organic Compounds			764	sulfur dioxide	SO ₂
C316	1,2-dichloro-1,2,3,3,4,4-hexafluorocyclobutane	C ₄ Cl ₂ F ₆	Unsaturated Organic Compounds		
C317	chloroheptafluorocyclobutane	C ₄ ClF ₇	1112a	1,1-dichloro-2,2-difluoroethene	CCl ₂ =CF ₂
C318	octafluorocyclobutane	C ₄ F ₈	1113	1-chloro-1,2,2-trifluoroethene	CClF=CF ₂
Zeotropic Blends (% by mass)			1114	tetrafluoroethene	CF ₂ =CF ₂
400	R-12/114 (must be specified)		1120	trichloroethene	CHCl=CCl ₂
401A	R-22/152a/124 (53/13/34)		1130	1,2-dichloroethene (trans)	CHCl=CHCl
401B	R-22/152a/124 (61/11/28)		1132a	1,1 difluoroethene (vinylidene fluoride)	CF ₂ =CH ₂
401C	R-22/152a/124 (33/15/52)		1140	1-chloroethene (vinyl chloride)	CHCl=CH ₂
402A	R-125/290/22 (60/2/38)		1141	1-fluoroethene (vinyl fluoride)	CHF=CH ₂
402B	R-125/290/22 (38/2/60)		1150	ethene (ethylene)	CH ₂ =CH ₂
			1270	propene (propylene)	CH ₃ CH=CH ₂

*The exact composition of this azeotrope is in question.

2.1.3 Clasificación según su composición.

Clorofluorocarbonos (CFC).

Estos refrigerantes son usados extensamente en equipos de aire acondicionado y refrigeración; entre los más usados esta el CFC-11, CFC-12, CFC-114, CFC-115. Estos gases refrigerantes poseen un valor de Potencial de Agotamiento del Ozono (ODP) distinto de cero. El Protocolo de Montreal que gobierna la eliminación de las sustancias agotadoras del Ozono en acuerdo internacional confirmo la paralización total de la producción de estos gases en el día 01 de Enero de 1996 para los países desarrollados y para el año 2010 para los países en vías de desarrollo.

Hidrofluorocarbonos (HCFC).

Estos refrigerantes poseen un tiempo de vida en la atmósfera y un valor de ODP menor que el de los CFC, sin embargo El Protocolo de Montreal acordó paralizar totalmente su producción para la misma fecha en que lo harán para los CFC. De estos el más usado es el CFC-22 y por su parte el CFC-123 esta siendo utilizado como sustituto del CFC-11.

Hidrofluorocarbonos (HFC).

Estos refrigerantes no poseen átomos de Cloro por lo que su valor de ODP es cero, esta característica los hace sustitutos potenciales de los CFC y los HCFC.

Fluorometanos.

Estos refrigerantes son producto de mezclas entre refrigerantes HFC por lo tanto su valor de ODP es cero y al igual que los HFC son sustitutos potenciales de los CFC y CFC.

Fluoroetanos.

Entre estos el más usado es el R-134a . Estos poseen un valor de ODP igual a cero y se utilizan como sustitutos del R-22 y R-12.

Fluoropropanos.

Este tipo de refrigerantes aun se encuentra en periodo de investigación y se espera sustituya al R-11.

Hidrocarbonos.

Entre estos se considera el Propano, el n-Butano (R-600), el isobutano (R-600a). Estos refrigerantes poseen un valor de ODP igual a cero y un valor bajo de Potencial de Calentamiento Global (GWP) pero son altamente inflamables, característica que significa un inconveniente para su utilización como gases refrigerantes.

Amonia (R-717).

Este es utilizado en compresores abiertos, posee una alta capacidad de refrigeración, poca reactividad con los lubricantes minerales.

Refrigerantes de mediana y alta presión.

El criterio para esta clasificación es la presión que presentan estos refrigerantes a una temperatura de 70 °F

Refrigerante R-12 (CCl₂F₂).

Es un refrigerante bastante seguro en el sentido de que no es toxico, no es inflamable y no es explosivo. Además es un compuesto altamente estable que es muy difícil

que falle aun bajo condiciones extremas de operación. Este refrigerante tiene la propiedad de que condensa a una presión moderada bajo condiciones atmosféricas normales y tiene una temperatura de ebullición de $-21,6^{\circ}\text{F}$ ($-29,8^{\circ}\text{C}$) a la presión atmosférica, esto hace que sea muy apropiado para usarse en aplicaciones de alta, media y baja temperatura y con cualquier tipo de compresor.

Entre las desventajas que presenta este refrigerante destaca su miscibilidad con aceite bajo cualquier condición, sin embargo esta condición tiende a aumentar la eficiencia y capacidad del sistema siempre y cuando se toman las precauciones del caso. Otra desventaja es su relativamente bajo efecto refrigerante por libra de refrigerante en comparación con otros.

Refrigerante R-22 (CHClF_2).

Originalmente fue desarrollado como refrigerante para temperatura baja. Se le usa extensamente en congeladores domésticos, sistemas industriales y comerciales de temperatura baja; por sus características se usa en acondicionadores de aire tipo paquete.

Posee un punto de ebullición a la presión atmosférica de -41.4°F ($-4^{\circ},8^{\circ}\text{C}$).

Refrigerante R-134a.

Este es un refrigerante del tipo HFC con propiedades similares a las del R-12. Se ha convertido en un nuevo estándar para la industria del aire acondicionado de automóviles, en aparatos de enfriamiento y refrigeración. El desempeño de este refrigerante no es el mejor a bajas temperaturas del evaporador; no se aplica a temperaturas por debajo de -10°F .

2.1.4 Efecto de los refrigerantes sobre los materiales de construcción.

Los refrigerantes halogenados pueden ser usados satisfactoriamente bajo condiciones normales con los metales más comunes como lo son; acero, latón, cobre, estaño y aluminio. Bajo condiciones extremas varios metales promueven cambios en las propiedades, hidrólisis y descomposición térmica.

El efecto de hidrólisis es similar para todos los metales. La tendencia a la descomposición térmica de los halogenados bajo ciertos metales sigue la siguiente relación:

INCONEL < 18 – 8 ACERO MICROALEADO < NICKEL < COBRE < ACERO 1340 < ALUMINIO < BRONCE < LATÓN < ZINC < PLATA.

2.1.5 Factores que disminuyen la eficiencia de los refrigerantes.

Los refrigerantes son productos químicos manufacturados bajo estrictas normas y especificaciones que satisfacen los requerimientos exigidos por los componentes de los sistemas de refrigeración.

Un contaminante es cualquier elemento o sustancia inherente o no al refrigerante que este fuera de los niveles de concentración o aceptación requeridos o normalizados.

La contaminación del refrigerante se puede llevar a cabo dentro del sistema de refrigeración o durante la manipulación del mismo para la carga o recuperación.

La ausencia de agentes contaminantes garantiza una mayor vida útil de los equipos, esto es, porque los contaminantes son la causa de la mayoría de las fallas a corto y largo plazo, además, la presencia de éstos incrementa los periodos de intervención de los sistemas, aumentando el tiempo fuera de servicio.

De los agentes contaminantes se debe considerar:

- Su fuente u origen.
- Las fallas que producen en el sistema de refrigeración.
- Las concentraciones o niveles de aceptación para el buen funcionamiento del equipo.

Los agentes contaminantes más comunes son:

- Aceite.
- Agua.
- Ácidos.

- Partículas sólidas.
- Gases no condensables.

Aceite.

El aceite puede ser un agente contaminante agresivo o no agresivo. Un aceite nuevo escogido de forma adecuada para el refrigerante es un contaminante no agresivo, sin embargo este puede convertirse en un cúmulo de agentes contaminantes agresivos, como lo son ácidos y partículas sólidas.

De allí que un aceite con muchas horas de funcionamiento no produce los mismos efectos que otro nuevo o en un refrigerante nuevo. El aceite y el refrigerante se mezclan en la mayoría de los sistemas de refrigeración. Esta propiedad de los refrigerantes de atrapar aceite hace estricto el control de la concentración de aceite en el refrigerante de rehusó. El exceso de aceite en el refrigerante produce una película que se adhiere a las paredes de la tubería del evaporador y el condensador disminuyendo la capacidad de transferencia de calor de estos equipos.

Existen dos formas de manejar aceite en un sistema de refrigeración:

1. Separar el aceite del refrigerante en la fase vapor a la salida del compresor. El aceite y el refrigerante deben ser no miscibles. El aceite retorna al compresor mediante métodos mecánicos o térmicos de separación. El contenido de aceite en el refrigerante es bajo.
2. El aceite circula por todo el sistema de refrigeración, la miscibilidad del aceite y el refrigerante debe ser suficiente en el rango de temperatura de uso tal que el aceite sea capaz de regresar al compresor. La cantidad de aceite en el circuito debe representar entre 1 y 5% de la cantidad de refrigerante.

Agua.

El agua es un contaminante que puede crear serias consecuencias en algunos sistemas. El agua puede solidificarse y obstruir las válvulas y pequeños orificios.

El agua puede generar una serie de reacciones catalíticas (a través del radical OH), estas reacciones de descomposición involucran al refrigerante y a los metales presentes en el circuito, promoviendo la formación de óxidos y ácidos corrosivos. Esto también causa deterioro del lubricante y la formación de sedimentos que tienden a obstruir los conductos de aceite, a rayar la superficie de las chumaceras, en general a reducir la vida del equipo. Por otra parte contribuye con el deterioro del aislamiento del devanado del motor en los equipos herméticos lo que acarrea el atterramiento del motor o corto circuito.

Por todo lo expuesto la cantidad de agua debe mantenerse lo más baja posible.

La fuente del agua es principalmente el aire y se distingue de dos formas:

1. Agua estancada en los equipos; esto es debido al manejo de los equipos (almacenamiento, tiempo en almacén, etc.).
2. Vapor de agua contenido en el aire que se encuentra inicialmente en los equipos.

Gases no condensables.

Estos se encuentran generalmente en el aire y son básicamente Nitrógeno y Oxígeno. Otra forma de que se hagan presentes en los sistemas es mediante reacciones químicas.

Estos gases producen efectos diferentes; el Oxígeno es un agente contaminante agresivo, ya que contribuye a la formación de óxidos y ácidos al participar en las reacciones químicas. Por su parte el Nitrógeno es un gas inerte y no tiene una acción agresiva directa.

Estos gases disminuyen la eficiencia del sistema, afectan la relación de compresión, dificultan la transferencia de calor en el condensador e incrementan la temperatura a la salida del compresor, lo que aumenta el peligro de descomposición de la mezcla refrigerante-aceite.

Ácidos.

Los ácidos que generalmente se producen por reacciones con refrigerantes halogenados son Hidroclóricos e Hidroflúricos, los cuales son altamente agresivos a los metales.

Estos ácidos se forman por la descomposición del refrigerante, la que se produce por la presencia de agua y óxidos mediante reacciones catalíticas.

Partículas sólidas.

Existe variedad en las fuentes de estos agentes contaminantes, estos pueden ser producto del proceso de soldadura, de corte de las tuberías y del proceso de instalación.

Otra fuente se genera cuando no existe suficiente compatibilidad entre el refrigerante, el aceite y los metales que conforman el sistema. Estas partículas se depositan en el compresor en el circuito de lubricación particularmente en los rodamientos del cigüeñal y en el plato de soporte de válvulas.

Estas partículas causan daños severos, por ejemplo, ocasionan un sello pobre de las válvulas.

Otra fuente es generada por las partes móviles.

2.1.6 Norma ARI 700.

El objetivo de esta norma es evaluar y aceptar o rechazar refrigerantes independientemente de su origen (ya sean nuevos, regenerados y/o reacondicionados) con miras a su uso en equipos nuevos y existentes de refrigeración y aire acondicionado, que corresponden a la esfera de alcance de la ARI (Air Conditioning and Refrigeration Institute). Esta norma busca orientar a la industria, en particular los fabricantes, empresas de regeneración de refrigerantes, profesionales del reacondicionamiento, distribuidores, instaladores, técnicos de mantenimiento y reparación, contratistas y consumidores.

En esta norma se especifican los niveles aceptables de contaminantes (requisitos de pureza) para diversos refrigerantes fluorocarbónicos y otros refrigerantes, independientemente de su origen, y se describen los métodos de prueba aceptables.

En el tabla N° 2 se muestran los niveles máximos aceptables de agentes contaminantes según la norma ARI 700.

TABLA N° 2. Niveles máximos de contaminantes en algunos refrigerantes.

	R11	R12	R13	R22	R23	R32	R113	R114	R123	R124	R125	R134a	R143a
Caracterización													
Punto de ebullición	74,9	-21,6	-114,6	-41,4	-115,7	-61,1	117,6	38,8	82,6	12,2	-55,3	-15,1	-52,6
°F @ 76 cm Hg.	[23,8]	[-29,8]	[-81,4]	[-40,8]	[-82,1]	[-51,7]	[47,6]	[3,8]	[27,9]	[-11,0]	[-48,5]	[-26,2]	[-47,0]
[EC @ 1,00 atm]	0,5	0,5	0,9	0,5	0,9	0,5	0,5	0,5	0,5	0,5	0,5	0,5	0,5
Gama de puntos de ebullición	[0,28]	[0,28]	[0,5]	[0,28]	[0,5]	[0,28]	[0,28]	[0,28]	[0,28]	[0,28]	[0,28]	[0,28]	[0,28]
°F[K]													
Contenido de isomero característico							0-1% R113a	0-30% R114a	0-8% R123a	0-5% R124a	N/A	0-5000 ppm R134	0-100 ppm R143
Impurezas													
Contaminantes en fase vapor (% máx. en volumen a 24° C)	N/A	1,5	1,5	1,5	1,5	1,5	N/A	1,5	N/A	1,5	1,5	1,5	1,5
Contenido de agua (liquido)	20	10	10	10	10	10	20	10	20	10	10	10	10
(ppm en peso)													
Iones de cloruro	3	3	3	3	3	3	3	3	3	3	3	3	3
(ppm máx. en peso)													
Acidez	1,0	1,0	1,0	1,0	1,0	1,0	1,0	1,0	1,0	1,0	1,0	1,0	1,0
(ppm máx. en peso)													
Residuo de alta ebullición	0,01	0,01	0,05	0,01	0,01	0,01	0,03	0,01	0,01	0,01	0,01	0,01	0,01
(máx. % en volumen)													
Partículas / Sólidos	OK	OK	OK	OK	OK	OK	OK	OK	OK	OK	OK	OK	OK
(Limpieza aceptable a simple vista)													
Todas las demás impurezas orgánicas incluidos refrigerantes	0,50	0,50	0,50	0,50	0,50	0,50	0,50	0,50	0,50	0,50	0,50	0,50	0,50
(máx. % en peso)													

2.2 Sistema de regeneración de refrigerantes.

2.2.1 Regeneración.

El Proceso de Regeneración se basa en reprocesar un refrigerante para darle las características de uno nuevo o virgen por diversos medios, en particular la destilación. (Norma ARI 740)

Según la norma ISO 11650R regeneración es procesar refrigerantes usados hasta llegar a las especificaciones de un producto nuevo.

2.2.2 Métodos de regeneración.

Existen dos métodos principales para la recuperación de refrigerantes, se entiende por recuperación la extracción completa de refrigerante de un sistema de refrigeración o aire acondicionado.

- Método de reutilización.
- Método de desecho.

La definición de estos métodos genera criterios para la reutilización de refrigerantes, definir lo que se denomina refrigerante “puro”, determinar los agentes contaminantes más comunes y las concentraciones aceptables de los mismos.

Destilación, Segregación y Ebullición son procesos utilizados en la separación de agentes contaminantes de refrigerantes; el uso de uno u otro depende de las características así como de la naturaleza de la separación.

2.2.2.1 Destilación.

Proceso que consiste en calentar un líquido hasta que sus componentes más volátiles pasan a la fase de vapor y a continuación, enfriar el vapor para recuperar dichos componentes en forma líquida por medio de la condensación.

El objetivo principal de la destilación es separar una mezcla de varios componentes aprovechando sus distintas volatilidades, o bien separar los materiales volátiles de los no volátiles. En la evaporación y en el secado, normalmente el objetivo es obtener el componente menos volátil; el componente más volátil, casi siempre agua, se desecha. Sin embargo, la finalidad principal de la destilación es obtener el componente más volátil en forma pura. Por ejemplo, la eliminación del agua de la glicerina evaporando el agua, se llama evaporación, pero la eliminación del agua del alcohol evaporando el alcohol se llama destilación, aunque se usan mecanismos similares en ambos casos.

Si la diferencia en volatilidad (y por tanto en punto de ebullición) entre los dos componentes es grande, puede realizarse fácilmente la separación completa en una destilación individual, en cambio si los puntos de ebullición de los componentes de una mezcla sólo difieren ligeramente, no se puede conseguir la separación total en una destilación individual. Por lo tanto debe repetirse el proceso de destilación varias etapas.

2.2.2.2 Segregación.

Proceso en el cual dos componentes en estado líquido pueden ser separados mediante enfriamiento ó cambio de presión. Luego los dos componentes pueden ser identificados y separados por una interfase; el componente menos denso se queda en la superficie. Este proceso no es de fácil implementación.

2.2.2.3 Ebullición.

Este es el método más simple para separar aceite y refrigerante, básicamente por la gran diferencia en los puntos de ebullición y presión de vapor de ambos componentes. Los refrigerantes de uso frecuente poseen un punto de ebullición a presión ambiente comprendido entre $-50\text{ }^{\circ}\text{C}$ y $25\text{ }^{\circ}\text{C}$ y los lubricantes utilizados en los sistemas de refrigeración poseen un punto de ebullición de $200\text{ }^{\circ}\text{C}$ a presión ambiente. El proceso de ebullición se puede realizar por:

- Calentamiento.
- Despresurización.
- Ambos métodos combinados.

La ebullición puede ocurrir por la reducción de la presión que produce la succión del compresor, que a su vez esta acompañada por el calor absorbido por el tanque que contiene el refrigerante contaminado. Sin embargo este calor cedido por el ambiente es pobre y a medida que el proceso continua la presión y temperatura del tanque contenedor tiende a caer y en consecuencia la tasa de refrigerante que ebulle. En consecuencia el método más eficiente para el proceso de ebullición es combinar el calentamiento con la despresurización.

Analizando estos métodos se opto por el uso del proceso de destilación, por ser este el más factible tanto técnico como económicamente. La tabla N° 3 muestra las propiedades físicas de los refrigerantes.

TABLA N° 3. Propiedades físicas de los Refrigerantes Fluorocarbónicos

No.	Refrigerant Chemical Name or Composition (% by mass)	Chemical Formula	Molecular Mass	Boiling Pt. (NBP) at 14.696 psia, °F	Freezing Point, °F	Critical Tempera- ture, °F	Critical Pressure, psia	Critical Volume, ft ³ /lb	Refractive Index of Liquid ^{b,c}
704	Helium	He	4.0026	-452.1	None	-450.3	33.21	0.2311	1.021 (NBP) 5461 Å
702p	Hydrogen, para	H ₂	2.0159	-423.2	-434.8	-400.3	187.5	0.5097	1.09 (NBP) ^f
702n	Hydrogen, normal	H ₂	2.0159	-423.0	-434.5	-399.9	190.8	0.5320	1.097 (NBP) 5791 Å
720	Neon	Ne	20.183	-410.9	-415.5	-379.7	493.1	0.03316	—
728	Nitrogen	N ₂	28.013	-320.4	-346.0	-232.4	492.9	0.05092	1.205 (83 K) 5893 Å
729	Air	—	28.97	-317.8	—	-220.95	548.9	0.0530	—
						-221.1	546.3	0.05007	
740	Argon	Ar	39.948	-302.55	-308.7	-188.48	704.9	0.0301	1.233 (84 K) 5893 Å
732	Oxygen	O ₂	31.9988	-297.332	-361.8	-181.424	731.4	0.03673	1.221 (92 K) 5893 Å
50	Methane	CH ₄	16.04	-258.7	-296	-116.5	673.1	0.099	—
14	Tetrafluoromethane	CF ₄	88.01	-198.3	-299	-50.2	543	0.0256	—
1150	Ethylene	C ₂ H ₄	28.05	-154.7	-272	48.8	742.2	0.070	1.363(-148) ^l
744A ²	Nitrous oxide	N ₂ O	44.02	-129.1	-152	97.7	1048	0.0355	—
170	Ethane	C ₂ H ₆	30.07	-127.85	-297	90.0	709.8	0.0830	—
503	R-23/13 (40.1/59.9)	—	87.5	-127.6	—	67.1	607	0.0326	—
23	Trifluoromethane	CHF ₃	70.02	-115.7	-247	78.1	701.4	0.0311	—
13	Chlorotrifluoromethane	CClF ₃	104.47	-114.6	-294	83.9	561	0.0277	1.146 (77) ⁴
744	Carbon dioxide	CO ₂	44.01	-109.2 ^d	-69.9 ^e	87.9	1070.0	0.0342	1.195 (59)
13B1	Bromotrifluoromethane	CBrF ₃	148.93	-71.95	-270	152.6	575	0.0215	1.239 (77) ⁴
504	R-32/115 (48.2/51.8)	—	79.2	-71.0	—	151.5	690.5	0.0324	—
32	Difluoromethane	CH ₂ F ₂	52.02	-61.1	-213	173.14	845.6	0.03726	—
125	Pentafluoroethane	C ₂ HF ₅	120.03	-55.43	-153.67	151.34	526.57	—	—
1270	Propylene	C ₃ H ₆	42.09	-53.86	-301	197.2	670.3	0.0720	1.3640 (-58) ^l
502 ⁵	R-22/115 (48.8/51.2)	—	111.63	-49.8	—	179.9	591.0	0.0286	—
290	Propane	C ₃ H ₈	44.10	-43.76	-305.8	206.1	616.1	0.0726	1.3397 (-43)
22	Chlorodifluoromethane	CHClF ₂	86.48	-41.36	-256	204.8	721.9	0.0305	1.234 (77) ⁴
115	Chloropentafluoroethane	CClF ₂ CF ₃	154.48	-38.4	-159	175.9	457.6	0.0261	1.221 (77) ⁴
500	R-12/152a (73.8/26.2)	—	99.31	-28.3	-254	221.9	641.9	0.0323	—
717	Ammonia	NH ₃	17.03	-28.0	-107.9	271.4	1657	0.068 ^d	1.325 (61.7)
12	Dichlorodifluoromethane	CCl ₂ F ₂	120.93	-21.62	-252	233.6	596.9	0.0287	1.288 (77) ⁴
134a	Tetrafluoroethane	CF ₂ CH ₂ F	102.03	-15.08	-141.9	214.0	589.8	0.029	—
152a	Difluoroethane	CHF ₂ CH ₃	66.05	-13.0	-178.6	236.3	652	0.0439	—
40 ²	Methyl chloride	CH ₃ Cl	50.49	-11.6	-144	289.6	968.7	0.0454	—
124	Chlorotetrafluoroethane	CHClF ₂ CF ₃	136.47	8.26	-326.47	252.5	530.84	—	—
600a	Isobutane	C ₄ H ₁₀	58.13	10.89	-255.5	275.0	529.1	0.0725	1.3514 (-13) ^l
764 ⁶	Sulfur dioxide	SO ₂	64.07	14.0	-103.9	315.5	1143	0.0306	—
142b	Chlorodifluoroethane	CClF ₂ CH ₃	100.5	14.4	-204	278.8	598	0.0368	—
630 ⁶	Methyl amine	CH ₃ NH ₂	31.06	19.9	-134.5	314.4	1082	—	1.432 (63.5)
C318	Octafluorocyclobutane	C ₄ F ₈	200.04	21.5	-42.5	239.6	403.6	0.0258	—
600	Butane	C ₄ H ₁₀	58.13	31.1	-217.3	305.6	550.7	0.0702	1.3562 (5) ^l
114	Dichlorotetrafluoroethane	CClF ₂ CClF ₂	170.94	38.8	-137	294.3	473	0.0275	1.294 (77)
21 ⁷	Dichlorofluoromethane	CHCl ₂ F	102.92	47.8	-211	353.3	750	0.0307	1.332 (77) ⁴
160 ²	Ethyl chloride	C ₂ H ₅ Cl	64.52	54.32	-216.9	369.0	764.4	0.0485	—
631 ⁶	Ethyl amine	C ₂ H ₅ NH ₂	45.08	61.88	-113	361.4	815.6	—	—
11	Trichlorofluoromethane	CCl ₃ F	137.38	74.87	-168	388.4	639.5	0.0289	1.362 (77) ⁴
123	Dichlorotrifluoroethane	CHCl ₂ CF ₃	152.93	82.17	-160.87	362.82	532.87	—	—
611 ⁶	Methyl formate	C ₂ H ₄ O ₂	60.05	89.2	-146	417.2	870	0.0459	—
141b	Dichlorofluoroethane	CCl ₂ FCH ₃	116.95	89.6	—	399.6	616.4	—	—
610 ⁶	Ethyl ether	C ₄ H ₁₀ O	74.12	94.3	-177.3	381.2	523	0.0607	1.3526 (68)
216ca	Dichlorohexafluoropropane	C ₃ Cl ₂ F ₆	220.93	96.24	-193.7	356.0	399.5	0.0279	—
30 ⁶	Methylene chloride	CH ₂ Cl ₂	84.93	104.4	-142	458.6	882	—	1.4244 (68) ³
113	Trichlorotrifluoroethane	CCl ₂ FCClF ₂	187.39	117.63	-31	417.4	498.9	0.0278	1.357 (77) ⁴
1130 ⁸	Dichloroethylene	CHCl=CHCl	96.95	118	-58	470	795	—	—
1120 ⁶	Trichloroethylene	CHCl=CCl ₂	131.39	189.0	-99	520	728	—	1.4782(68) ³
718 ⁶	Water	H ₂ O	18.02	212	32	705.18	3200	0.0498	—

Notes:

^aData from ASHRAE *Thermodynamic Properties of Refrigerants* (Stewart et al. 1986) or from McLinden (1990), unless otherwise noted.^bTemperature of measurement (°F, unless kelvin is noted) shown in parentheses. Data from CRC *Handbook of Chemistry and Physics* (CRC 1987), unless otherwise noted.^cFor the sodium D line.^dSublimes.^eAt 76.4 psia.^fDielectric constant data.

References:

¹Kirk and Othmer (1956).²Matheson Gas Data Book (1966).³Electrochemicals Department, E.I. duPont de Nemours & Co.⁴Bulletin B-32A (duPont).⁵Bulletin T-502 (duPont 1980).⁶Handbook of Chemistry (1967).⁷Bulletin G-1 (duPont).⁸CRC Handbook of Chemistry and Physics (CRC 1987).

2.3 Equipos que conforman el Sistema de Regeneración de Refrigerantes.

El sistema de regeneración de refrigerantes esta conformado por los siguientes equipos:

- Cámara de destilación.
- Compresor.
- Condensador.
- Válvulas de control de flujo.
- Tuberías.
- Visores y Filtros.

2.3.1 Cámara de destilación.

La cámara de destilación es un equipo donde el refrigerante sufre un cambio de fase desde liquido saturado a vapor ligeramente sobrecalentado, a través de un proceso de calentamiento, esto con la finalidad de destilar principalmente la mezcla refrigerante-lubricante del refrigerante contaminado. Este proceso de destilación se denomina destilación individual o destilación flash debido a la diferencia entre los puntos de ebullición del aceite y el refrigerante. El proceso de calentamiento se puede realizar de distintas formas, por ejemplo el uso de un intercambiador de calor utilizando como fluido de calentamiento agua o cualquier otra sustancia o mezcla. Como nuestro sistema debe ser un equipo portátil, optamos por el uso de una resistencia eléctrica como dispositivo para suministrar el calor necesario en la evaporación del refrigerante contaminado, además de ser esta la opción más económica.

2.3.2 Compresor.

El compresor en un sistema de refrigeración tiene como función bombear el refrigerante del evaporador incrementando su presión, y este incremento de presión debe

ser el necesario para producir condensación a la temperatura estipulada por la capacidad y rata de flujo del medio condensante en el condensador.

Para nuestro propósito optamos por el uso de un compresor reciprocante del tipo abierto, ya que este tiene los implementos de compresión totalmente desligados del sistema motor y por esto el refrigerante solo entra en contacto con el sistema de compresión lo que significa en un proceso más limpio y desde el punto de vista del mantenimiento ideal.

2.3.3 Condensador.

El condensador es una superficie de transferencia de calor. El calor del vapor refrigerante caliente pasa a través de las paredes del condensador para su condensación. Como resultado de su pérdida de calor hacia el medio condensante, el vapor refrigerante es primero enfriado hasta saturación y después condensado hasta su fase de estado líquido. En la mayoría de los casos el medio condensante empleado es aire o agua o una combinación de ambos.

El calor total rechazado en el condensador incluye el calor absorbido en el evaporador y la energía equivalente del trabajo de compresión, además de cualquier sobrecalentamiento que absorba el vapor refrigerante. El calor rechazado por el condensador depende de las condiciones de operación del sistema, por ejemplo el calor de compresión varía con el diseño del compresor siendo mayor este en un compresor hermético que en un compresor tipo abierto.

2.3.4 Válvulas.

Existen cinco tipos básicos de válvulas para el control del flujo de refrigerante:

- Válvula de expansión manual.
- Válvula de expansión automática.
- Válvula de expansión termostática.
- Válvula de flotador.
- Válvula solenoide.

Independientemente del tipo, estos equipos de control de flujo tienen dos funciones:

- Medir el refrigerante líquido en la tubería de líquido que va hacia el evaporador con una rapidez que sea proporcional a la cual está ocurriendo la evaporación.
- Mantener un diferencial de presión entre los lados de alta y baja presión del sistema con el fin de vaporizar el refrigerante bajo las condiciones de baja presión deseadas en el evaporador y al mismo tiempo efectuar la condensación a la presión alta que se tiene en el condensador.

2.3.5 Tuberías.

Para el diseño de las tuberías en un sistema en el que el fluido es refrigerante se debe considerar:

- Costos de instalación
- Pérdidas por fricción (caídas de presión)

Entre los análisis de costos de instalación se toman en cuenta el material de las tuberías y las dimensiones de las mismas para que las pérdidas por fricción sean aceptables de manera que el funcionamiento sea óptimo.

En cuanto a las pérdidas por fricción estas repercuten en el consumo de energía.

Los materiales más frecuentemente utilizados en las tuberías que transportan refrigerante son acero, hierro, cobre y latón. Todos estos materiales son apropiados para utilizarse con los refrigerantes más comunes, excepto el cobre y el latón que no pueden ser utilizados con amoníaco como refrigerante, debido a que en presencia de humedad el amoníaco ataca a los metales no ferrosos.

La tubería de cobre tiene la ventaja de ser de peso ligero, más resistente a la corrosión y de fácil instalación. Tuberías de diámetro exterior hasta 100mm (4 1/8 pulg.)

pueden ser de cobre o de acero, para diámetros mayores deben ser de acero. El hierro dulce es muy resistente a la corrosión pero su precio es elevado.

Las tuberías de cobre pueden ser de temple duro o suave. Para tubos usados en refrigeración sólo son apropiados los tipos K y L.

Las tuberías de cobre de temple suave pueden usarse en trabajos de refrigeración hasta un diámetro externo de 7/8 pulg. (20 mm) y se recomienda usarlos donde sea necesario hacer flexiones o vueltas, donde la tubería esté oculta y/o donde se usan conexiones con otros tubos. Las tuberías de temple duro deberán usarse para tamaños mayores de 7/8 pulg. de diámetro exterior (22 mm) y para tamaños menores donde se desea tener rigidez.

2.3.6 Filtros.

Son dispositivos que protegen los sistemas por medio de la absorción y retención de la humedad presente en los refrigerantes y aceites lubricantes, además, filtran y acumulan los agentes ácidos y las partículas sólidas. Con estos se evita el deterioro de las válvulas, tubo capilar y demás componentes de los sistemas. Los filtros deberán colocarse inmediatamente enfrente de todas las válvulas. Se recomienda usar secadores de refrigerantes para todos los sistemas de refrigeración que emplean refrigerante halocarburos. Para la selección de estos dispositivos se deben tomar en consideración factores tales como, tipo de sistema, tamaño de las líneas de conexión, capacidad de flujo, capacidad de filtración, material de construcción, presiones de trabajo.

CAPITULO 3. DEFINICIÓN DE LOS PARÁMETROS DE DISEÑO.

3.1 Norma ARI 740.

La presente norma se aplica a los equipos de recuperación y/o regeneración de refrigerantes puros, azeotropos de los sistemas frigoríficos y a los contaminantes que éstos suelen contener. No atañe a la recuperación y/o regeneración de mezclas de refrigerantes de los sistemas de aire acondicionado o refrigeración o que existen en contenedores de almacenamiento. En términos generales, no existe una tecnología que permita separar refrigerantes mediante equipos de recuperación y/o regeneración.

La presente norma tiene por objeto establecer los métodos de prueba para estimar y evaluar la eficacia de la regeneración de refrigerantes, así como las condiciones generales aplicables a los equipos en términos de contaminantes o de pureza, de capacidad, velocidad y pérdidas durante la purga, a fin de reducir al mínimo la pérdida de refrigerante a la atmósfera.

3.2 Parámetros de diseño.

De acuerdo con los requerimientos de la empresa *INGARSICA C.A.*, se tienen las siguientes especificaciones para el diseño del sistema de regeneración de refrigerantes de mediana y alta presión:

- El sistema debe regenerar refrigerantes de mediana y alta presión.
- Debe ser capaz de satisfacer una capacidad de producción de 400 toneladas métricas por año.
- Debe ser compacta y de fácil transportación.

3.2.1 Descripción del Proceso de Regeneración.

En el sistema de regeneración de refrigerantes el refrigerante contaminado entra desde un recipiente a presión en el cual este se encuentra a la presión de saturación a temperatura ambiente que para nuestros cálculos fue establecida en 40 °C. De este recipiente pasa a través de una serie de filtros con el fin de eliminar agentes contaminantes tales como partículas sólidas, humedad, aceite lubricante hasta llegar a la cámara de destilación; las condiciones en esta son las de liquido saturado a 10 °C. En la cámara de destilación el refrigerante sufre un cambio a la fase de vapor mediante un proceso de destilación hasta una condición de vapor saturado seco. De la salida de la cámara de destilación pasa a través de unos filtros para llegar al compresor con una condición de $T = 25\text{ °C}$. El compresor eleva la presión del gas a un nivel en el cual la condensación puede ocurrir a una temperatura dada. Para nuestro caso esta temperatura es de 50 °C. Este condensado finalmente es confinado en un recipiente a presión para su respectivo control de calidad y despacho. En la figura N° 1 se muestra un flujograma del proceso, en donde se pueden observar las condiciones de operación del mismo.



Figura N° 1. Flujograma del Proceso de Regeneración.

3.2.2 Condiciones de la cámara de destilación.

La cámara de destilación es un recipiente a presión en donde el refrigerante será destilado con el fin de efectuar la separación de la mezcla refrigerante-agentes contaminantes. Este proceso se denomina destilación simple por el hecho de que la mezcla consta de dos componentes, por otra parte debido a la gran diferencia entre los puntos de ebullición de ambos componentes de la mezcla se denomina destilación individual. El proceso de destilación consiste en la evaporación del componente más volátil y su posterior recuperación por medio de su condensación. De acuerdo con estudios efectuados el proceso de calentamiento del refrigerante en la cámara de destilación debe realizarse en un rango de temperaturas entre 10 y 50 °C.

Para la realización del proceso optamos por el uso de resistencias eléctricas como medio para la generación del calor necesario para la evaporación.

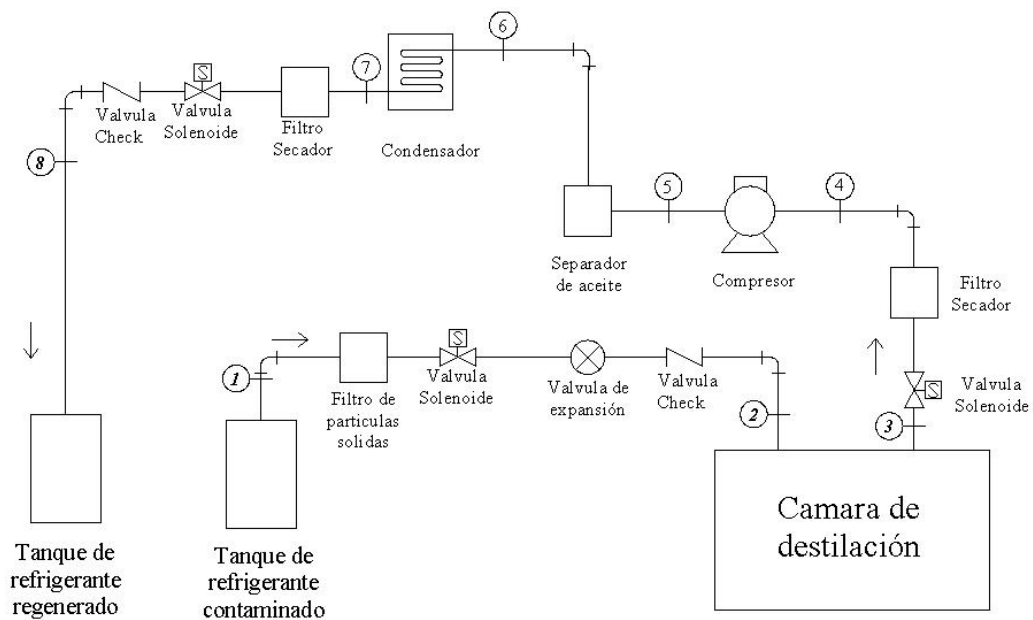
Esta cámara consta además de dispositivos de control de nivel para la regulación de flujo hacia la misma, así como para el control del encendido de las resistencias.

3.2.3 Criterio de selección de la válvula de expansión.

Para la selección de la válvula de expansión se deben tener definidos parámetros como, límite de presión de trabajo, tamaño de las conexiones, temperatura en el evaporador, capacidad del sistema, para con esto determinar la razón de flujo necesario a través de la válvula. Luego de definir estos parámetros se determina cual es el tipo de válvula con mejor desempeño en los catálogos de los distintos fabricantes. Las válvulas de expansión vienen especificadas según la carga en toneladas de refrigeración (Btu/hr) para diferentes condiciones de operación.

Para nuestro propósito y por el hecho de trabajar con varios refrigerantes los cuales poseen características de trabajo diferentes (presión, densidad), debemos utilizar válvulas individuales para cada tipo de refrigerante.

3.2.4 Criterios de selección del condensador.

Las especificaciones de las capacidades de los condensadores generalmente se dan en calor transferido por unidad de tiempo (Btu/hr) para varias condiciones de operación. Con el área superficial y el valor U fijados por el fabricante, la capacidad del condensador dependerá únicamente de la diferencia de temperatura media entre el aire y el refrigerante. La mayoría de los condensadores vienen equipados con ventiladores, la cantidad de aire que circula por el condensador esta previamente establecida por esto la temperatura del medio condensante depende solamente de la temperatura de bulbo seco del aire de la entrada y de la carga del condensador. En estos casos la capacidad del condensador es directamente proporcional a la diferencia de temperatura entre la temperatura de bulbo seco del aire de la entrada y la temperatura del refrigerante.

En la practica los rangos de diferencia de temperatura en el condensador son de 15 a 35° F. Esta diferencia en el rango alto deberán ser limitadas a aquellas aplicaciones de temperatura de temperatura alta y/o a lugares donde la temperatura de bulbo seco de diseño exterior sea relativamente baja.

3.2.5 Criterios de selección del compresor.

Para la selección del compresor se debe definir el refrigerante a utilizar y la capacidad del mismo. Esta se define como el volumen de refrigerante evaporado que el compresor puede comprimir y llevar a el condensador en un tiempo dado.

La capacidad teórica de un compresor es determinada al encontrar el desplazamiento de un solo pistón, en términos de pies cúbicos, y luego multiplicando este valor por el número de cilindros y la velocidad del compresor en revoluciones por minuto (rpm). Este calculo nos da la capacidad teórica del compresor en pies cúbicos de desplazamiento por minuto (cfm de sus siglas en ingles), o viéndolo de otra forma, el volumen de refrigerante evaporado que el compresor es capaz de bombear en un minuto, si este fuera 100 % eficiente.

Sin embargo, hay ciertos factores que influyen en la capacidad del compresor, el principal factor es la relación de compresión. Esta se obtiene de la división entre la presión de descarga absoluta y la presión de succión.

De la figura N° 2, se puede observar que a medida que la relación de compresión aumenta, disminuye la eficiencia volumétrica, o sea la habilidad de el compresor para bombear vapor refrigerante.



Figura N° 2. Eficiencias aproximadas del compresor para R22 y R12

Si por ejemplo, 10 pies cúbicos de refrigerante evaporado deben ser bombeados cada minuto, entonces un compresor que opere con una relación de compresión de 3, tendrá una eficiencia volumétrica del 82%.

La eficiencia volumétrica de un compresor puede determinarse mediante la siguiente ecuación:

$$n_{vol} = \frac{D_{real}}{D_{teorico}} \quad (1)$$

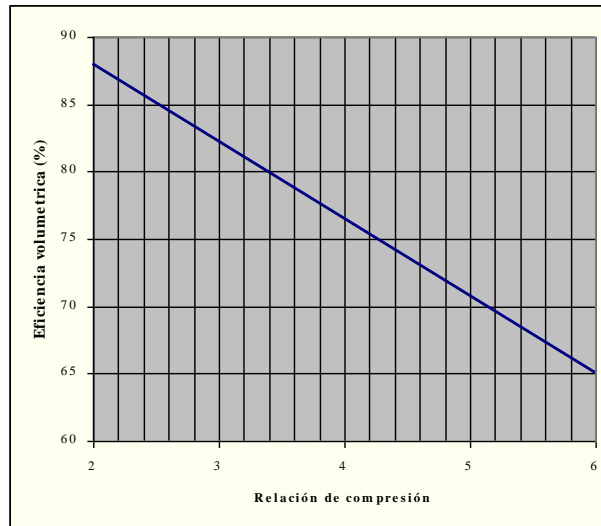
donde:

n_{vol} = eficiencia volumétrica del compresor.

D_{real} = desplazamiento real del compresor.

$D_{teórico}$ = desplazamiento teórico del compresor.

Para eliminar el tiempo requerido para hacer tales cálculos cada vez que un compresor va a ser seleccionado, los fabricantes publican tablas de capacidad de compresores, en donde ya se toman en cuenta los factores nombrados anteriormente que influyen en la capacidad del compresor.

CAPITULO 4. DISEÑO Y SELECCIÓN DE EQUIPOS.

4.1 Cámara de destilación.

Las condiciones del tanque de refrigerante contaminado y la cámara de destilación pueden verse en la siguiente figura:



Figura N° 3. Condiciones termodinámicas de la cámara de destilación.

Estas condiciones corresponden en el diagrama de flujo de la figura N° 1 a los puntos (1) y (2). La cantidad de calor que se debe suministrar al refrigerante para evaporarlo es determinado aplicando la primera ley de la termodinámica:

$$\dot{Q} + \sum \dot{m}_i \left(h_i + \frac{V_i^2}{2} + gz_i \right) = \dot{W} + \sum \dot{m}_e \left(h_e + \frac{V_e^2}{2} + gz_e \right) \quad (2)$$

despreciando los términos de energía potencial y energía cinética, tenemos:

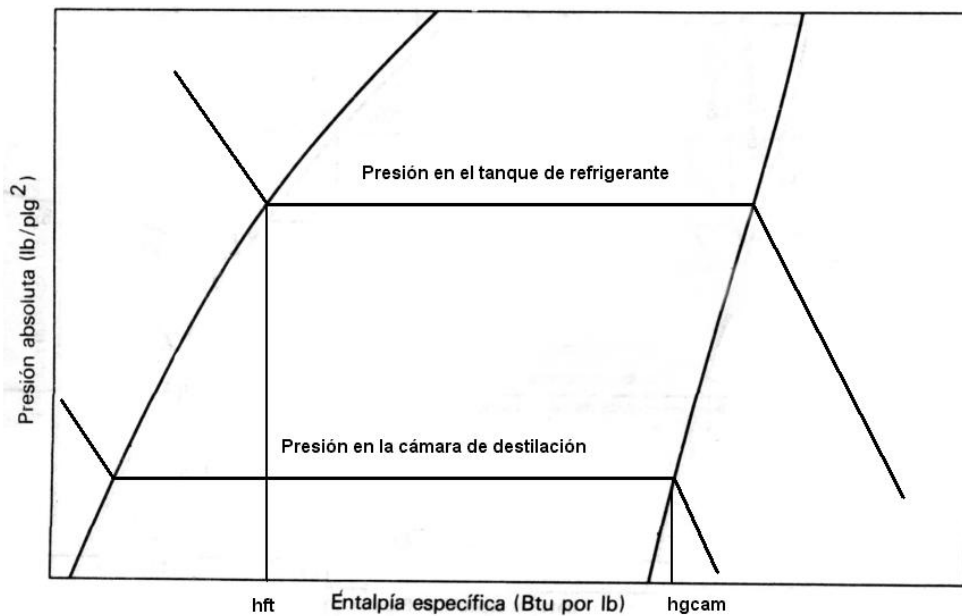
$$\dot{Q} + \sum \dot{m}_i (h_i) = \dot{W} + \sum \dot{m}_e (h_e) \quad (3)$$

como no se realiza ningún trabajo, entonces nos queda, despejando \dot{Q} la siguiente expresión:

$$\dot{Q}_{cam} = \dot{m}_{ref} (h_{gcam} - h_{ft}) \quad (4)$$

donde:

\dot{Q}_{cam} = tasa de calor necesario para evaporar el refrigerante en (Btu/h).

\dot{m}_{ref} = flujo másico de refrigerante que recorre el sistema en (lb/h.).

h_{gcam} = entalpía del refrigerante a la salida de la cámara de destilación en (Btu/lb).

h_{ft} = entalpía del refrigerante a la entrada de la cámara de destilación en (Btu/lb).

Del diagrama de presión versus entalpía, se observa que a medida que la presión en la cámara de destilación disminuye, la diferencia de entalpías entre la entrada y la salida disminuye, por lo tanto el calor que se debe suministrar al refrigerante también se reduce.

Sin embargo, cuando se disminuye la presión en la cámara, hay un aumento en el trabajo de compresión como se observa en la figura N° 2. Además, existe el problema de que a la entrada del compresor, al disminuir la presión de succión, disminuye la densidad del vapor, esto quiere decir que por cada volumen unitario de vapor comprimido en el compresor, la masa de refrigerante que circula por el compresor para un mismo desplazamiento del pistón disminuye, en consecuencia la capacidad requerida del compresor es menor.

Desde el punto de vista de la miscibilidad del aceite y el refrigerante, al aumentar la temperatura del refrigerante, la miscibilidad aumenta, pero si la temperatura es muy baja el aceite tiende a congelarse y se hace mas viscoso, por lo que podría formarse una capa de aceite en las resistencias, reduciendo la capacidad de estas para transferir calor.

De lo anterior, se observa que se debe mantener la temperatura de evaporación en un cierto rango. Investigaciones recomiendan que este rango de temperatura sea de 10 a 50° C.

Para determinar el flujo másico que pasa por el sistema, tomamos como base los siguientes datos suministrados por la empresa:

- La maquina debe estar en capacidad de manejar una producción total anual de 400 toneladas métricas como mínimo.
- Los días hábiles que trabajará la maquina en un año lo estiman en 300.
- El ritmo de trabajo de la maquina es de 6 horas diarias.

$$\dot{m} = 400 \frac{TM}{año} * 1000 \frac{kg}{TM} * \frac{1 \text{ año}}{300 \text{ días}} * \frac{1 \text{ día}}{6 \text{ horas}} \quad (5)$$

Entonces, el flujo másico mínimo es:

$$\dot{m}_{\min} = 222.22 \frac{kg}{hora} = 488.89 \frac{lb}{hora}$$

4.1.1 Balance energético.

La condición de entrada del refrigerante a la cámara de destilación la tomamos de las condiciones de saturación del refrigerante a la temperatura ambiente. Entonces de las tablas de propiedades para liquido y vapor saturado, tenemos que para R22 a una temperatura de 40 °C (105 °F):

Presión (P_t) = 225.53 psia.

Densidad del liquido (ρ_{ft}) = 70.29 lb/pie³.

Volumen específico del vapor (v_{gt}) = 0.2379 pie³/lb.

Entalpía del líquido (h_{ft}) = 41.119 Btu/lb.

Entalpía del vapor (h_{gt}) = 112.278 Btu/lb.

La condición del refrigerante dentro de la cámara se especifican para una temperatura de evaporación de 10 °C (50 °F), por lo tanto:

Presión (P_{cam}) = 98.8 psia.

Densidad del líquido (ρ_{fcam}) = 77.84 lb/pie³.

Volumen específico del vapor (v_{gcam}) = 0.5548 pie³/lb.

Entalpía del líquido (h_{fcam}) = 24.544 Btu/lb.

Entalpía del vapor (h_{gcam}) = 108.997 Btu/lb.

El calor necesario para evaporar el refrigerante es, de la ecuación N° 4 igual a:

$$Q_{evapR22} = 488.89 \frac{lb}{hora} * (108.997 - 41.119) \frac{Btu}{lb} * \frac{1Kw}{3412 \frac{Btu}{hr}}$$

$$\Rightarrow Q_{evapR22} = 9.73Kw$$

entonces, el calor que deben aportar las resistencias eléctricas es de 9.73 Kw.

Haciendo lo mismo para los otros refrigerantes tenemos que:

Para R134a a una temperatura de 40 °C (105 °F):

$$\text{Presión (P}_t\text{)} = 149.63 \text{ psia.}$$

$$\text{Densidad del liquido (}\rho_{ft}\text{)} = 71.43 \text{ lb/pie}^3.$$

$$\text{Volumen especifico del vapor (}v_{gt}\text{)} = 0.3153 \text{ pie}^3/\text{lb.}$$

$$\text{Entalpía del liquido (}h_{ft}\text{)} = 46.725 \text{ Btu/lb.}$$

$$\text{Entalpía del vapor (}h_{gt}\text{)} = 116.694 \text{ Btu/lb.}$$

La condición del refrigerante dentro de la cámara se especifican para una temperatura de evaporación de 10 °C (50 °F), por lo tanto:

$$\text{Presión (P}_{cam}\text{)} = 60.116 \text{ psia.}$$

$$\text{Densidad del liquido (}\rho_{fcam}\text{)} = 78.67 \text{ lb/pie}^3.$$

$$\text{Volumen especifico del vapor (}v_{gcam}\text{)} = 0.7925 \text{ pie}^3/\text{lb.}$$

$$\text{Entalpía del liquido (}h_{fcam}\text{)} = 27.994 \text{ Btu/lb.}$$

$$\text{Entalpía del vapor (}h_{gcam}\text{)} = 110.058 \text{ Btu/lb.}$$

Luego, el calor necesario para evaporar el refrigerante es, de la ecuación N° 4 igual a:

$$Q_{evapR134a} = 488.89 \frac{\text{lb}}{\text{hora}} * (110.058 - 46.725) \frac{\text{Btu}}{\text{lb}} * \frac{1\text{Kw}}{3412 \frac{\text{Btu}}{\text{hr}}}$$

$$\Rightarrow Q_{evapR134a} = 9.07 \text{ Kw}$$

entonces, el calor que deben aportar las resistencias eléctricas es de 9.07 Kw.

Para R12 a una temperatura de 40 °C (105 °F):

Presión (P_t) = 141.01 psia.

Densidad del liquido (ρ_{ft}) = 78.16 lb/pie³.

Volumen especifico del vapor (v_{gt}) = 0.2901 pie³/lb.

Entalpía del liquido (h_{ft}) = 32.474 Btu/lb.

Entalpía del vapor (h_{gt}) = 88.059 Btu/lb.

La condición del refrigerante dentro de la cámara se especifican para una temperatura de evaporación de 10 °C (50 °F), por lo tanto:

Presión (P_{cam}) = 61.316 psia.

Densidad del liquido (ρ_{fcam}) = 85.08 lb/pie³.

Volumen especifico del vapor (v_{gcam}) = 0.6621 pie³/lb.

Entalpía del liquido (h_{fcam}) = 19.501 Btu/lb.

Entalpía del vapor (h_{gcam}) = 82.927 Btu/lb.

El calor necesario para evaporar el refrigerante es, de la ecuación N° 4 igual a:

$$Q_{evapR12} = 488.89 \frac{lb}{hora} * (82.927 - 32.474) \frac{Btu}{lb} * \frac{1Kw}{3412 \frac{Btu}{hr}}$$

$$\Rightarrow Q_{evapR12} = 7.23Kw$$

entonces, el calor que deben aportar las resistencias eléctricas es de 7.23 Kw.

4.1.2 Cálculo del volumen.

En este caso se debe tomar en cuenta el volumen específico de la mezcla líquido-vapor de refrigerante que esta dentro de la cámara, así como también la cantidad de máxima de masa que va a estar dentro de la misma.

Se requiere que el refrigerante en estado líquido que este dentro de la cámara ocupe 60% del volumen de la misma, entonces tenemos:

$$v = 0.6v_f + 0.4v_g \quad (6)$$

Tomando en cuenta que el volumen específico es el inverso de la densidad, entonces nos queda:

$$v_{cam} = 0.6 \frac{1}{\rho_{fcam}} + 0.4v_{gcam} \quad (7)$$

donde:

v_{cam} = volumen específico de la mezcla líquido-vapor dentro de la cámara.

ρ_{fcam} = densidad del refrigerante líquido dentro de la cámara.

v_{gcam} = volumen específico del refrigerante en forma de vapor en la cámara.

Entonces, para el R22:

$$v_{cam} = \left(0.6 \frac{1}{77.84 \frac{lb}{pie^3}} + 0.4 * 0.5548 \frac{pie^3}{lb} \right) * \frac{1 \frac{m^3}{kg}}{16 \frac{pie^3}{lb}}$$

$$\Rightarrow v_{cam} = 0.01435 \frac{m^3}{kg}$$

La cantidad de masa que va estar dentro de la cámara se puede fijar en 10 Kg. ya que la bombona mas pequeña de refrigerante almacena 12 Kg, esto asegura que la cámara se va a llenar hasta el máximo nivel antes de comenzar el proceso.

Entonces el volumen de la cámara será:

$$V_{cam} = m_{cam} * v_{cam} \tag{8}$$

donde:

m_{cam} = masa dentro de la cámara en (kg).

Calculando:

$$V_{cam} = 10 * 0.01435$$

$$V_{cam} = 0.1435 m^3$$

Para un tanque cilíndrico, el volumen viene dado por la siguiente expresión:

$$V_{cam} = \frac{\pi}{4} (D_{cam})^2 L_{cam} \quad (9)$$

de esta ecuación, despejando L_{cam} queda:

$$L_{cam} = \frac{4}{\pi} (D_{cam})^{-2} V_{cam} \quad (10)$$

donde:

L_{cam} = longitud de la cámara de destilación.

D_{cam} = diámetro de la cámara de destilación.

V_{cam} = Volumen de la cámara de destilación.

Sí se toma inicialmente un diámetro de 0.50 metros y un volumen de 0.1435 m^3 , la longitud es:

$$L_{cam} = \frac{4}{\pi} (0.5m)^{-2} * 0.1435m^3$$

$$\Rightarrow L_{cam} = 0.73m.$$

Por lo tanto se selecciona una longitud de 73 cm.

Para calcular el nivel hasta donde va a llegar el liquido en la cámara de destilación, de los anexos tenemos la formula:

$$\text{volumen total} * \text{coeficiente} = \text{volumen parcial} \quad (11)$$

pero en nuestro caso, ya el coeficiente se tiene, debido a que la cámara debe tener 60 % de liquido, el coeficiente vale 0.6, entonces de la tabla del anexo se tiene que el valor de la relación H/D es 0.58.

De esta relación se obtiene que la altura del nivel de liquido debe ser de:

$$H = 0.58 * 0.5 \text{ m.}$$

$$H = 0.29 \text{ m.}$$

4.1.3 Cálculo del espesor de pared y selección del material.

Basados en las normas de Calderas y recipientes sujetos a presión de la ASME, se trabaja con una presión de diseño de trabajo de 30 lbs/pulg² o 10% más de la presión de trabajo. Utilizando como presión de trabajo la presión de saturación del R22 a 10 °C:

$$P_{\text{cam}} = 98.8 \text{ psia}$$

La presión de diseño puede ser:

$$P_d = P_{\text{cam}} + 0.1P_{\text{cam}} = 98.8 \text{ psia} + 0.1 * 98.8 \text{ psia} = 108.7 \text{ psia}$$

O también:

$$P_d = P_{cam} + 30 \text{ psia} = 98.8 \text{ psia} + 30 \text{ psia} = 128.8 \text{ psia}$$

tomando el valor mayor, se tiene que la presión de diseño es:

$$P_d = 130 \text{ psia}$$

El espesor requerido de pared para tuberías se calcula con la siguiente formula:

$$t = \frac{PR}{SE - 0.6P} \quad (12)$$

en la cual:

t = espesor de pared mínimo requerido en el tubo en (pulg).

P = presión interna de diseño en (lb/pulg² man).

S = 15000 lb/pulg², valor de esfuerzo del material de uso mas común para tubería, el SA-53B a temperaturas de -20 a 650 °F para servicio general, (ver anexo).

E = eficiencia de la junta de soldadura.

R = radio interior de la tubería en (pulg).

Entonces tenemos los siguientes datos:

P = se usará la presión absoluta, lo cual nos da un factor de seguridad.

R = 0.25 metros = 10 pulgadas de radio nominal.

E = 1.

Por lo tanto de la ecuación N° 12 :

$$t = \frac{130 \frac{lb}{pulg^2} * 10 pulg}{15000 \frac{lb}{pulg^2} * 1 - 0.6 * 130 \frac{lb}{pulg^2}}$$

$$\Rightarrow t = 0.087 pulg$$

tomando un margen por corrosión (C.A.) de 0.125 pulg., nos queda que el espesor real es de:

$$t_{casco} = t + C.A = 0.087 + 0.125 \quad (13)$$

$$\Rightarrow t_{casco} = 0.212 pulg.$$

Se toma un valor nominal de espesor igual a ¼ de pulgada, o sea un tubo de 20 pulgadas de diámetro nominal con Schedule 10 (ver anexo), entonces el espesor es:

$$\Rightarrow t_{casco} = 0.00635m.$$

Para las cabezas del tanque, se seleccionan del tipo circular plano, debido a que en ellas van a ir colocadas las resistencias y los controladores de nivel. El espesor de estas cabezas viene expresado por las siguientes ecuaciones (ver anexo):

$$t = d\sqrt{0.13P/SE} \quad (14)$$

Esta formula se aplica cuando:

1. d no exceda de 24 pulgadas.
2. t/d no sea menor de 0.05 ni mayor de 0.25.
3. El espesor de la cabeza (t_h), no sea menor que el espesor del casco (t_s).

Si algunas de las condiciones anteriores no se cumple, se utiliza esta otra formula:

$$t = d\sqrt{CP/SE} \quad (15)$$

$$C = 0.33\frac{t_r}{t_s} \quad (16)$$

donde:

t_r = espesor mínimo requerido, por presión, del casco sin costura en (pulg).

t_s = espesor real del casco, excluyendo el margen por corrosión en (pulg).

Entonces con los siguientes datos:

$t_r = 0.087$ pulgadas.

$t_s = 0.125$ pulgadas.

$P = 130$ lb/pulg².

$S = 15000 \text{ lb/pulg}^2$, valor de esfuerzo del material para la placa, el SA-516-60 a temperaturas de -20 a 650 °F para servicio a temperaturas moderada y baja, (ver anexo).

$$E = 0,6.$$

De la ecuación N° 14:

$$t = 20 \text{ pulg} \sqrt{0.13 * 130 \frac{\text{lb}}{\text{pulg}^2} / 15000 \frac{\text{lb}}{\text{pulg}^2} * 0,6}$$

$$\Rightarrow t = 0.87 \text{ pulg}$$

Verificando la limitación de:

$$t_h/d = 0.87/20 = 0.0435.$$

este es un valor menor de 0.05, por lo tanto la relación del espesor de la cabeza al diámetro del casco no es satisfactoria, por lo tanto se usa la ecuación N° 15:

$$C = 0.33 \frac{0.087}{0.125} = 0.2297$$

$$t = 20 \text{ pulg} \sqrt{0.2297 * 130 \frac{\text{lb}}{\text{pulg}^2} / 15000 \frac{\text{lb}}{\text{pulg}^2} * 0.6}$$

$$\Rightarrow t = 1,15 \text{ pulg}.$$

tomando un margen por corrosión (C.A.) de 0.125 pulg., nos queda que el espesor real es de la ecuación N° 13:

$$t' = t + C.A = 1,15 + 0.125$$

$$\Rightarrow t' = 1.275 \text{ pulg} = 0.0324 \text{ m}$$

Se selecciona una placa de espesor nominal 32 mm.

4.1.4 Cálculo de las silletas.

Las silletas son los apoyos donde va a descansar la cámara de destilación. En nuestro caso la cantidad de apoyos va es dos. Para su cálculo se necesita saber el peso de la cámara de destilación llena de refrigerante.

Dicho peso viene dado por la siguiente expresión.

$$W_{cam} = \rho_{mat} * V_{mat} \quad (17)$$

donde:

W_{cam} = peso de la cámara en kg.

ρ_{mat} = densidad del material en kg/m^3 .

V_{mat} = volumen que ocupa dicho material en m^3 .

Para la densidad del material, se toma como valor la del acero común, igual a $0.282 \text{ lb/pulg}^3 = 7805.7 \text{ kg/m}^3$.

El volumen se calcula por medio de esta expresión:

$$V_{mat} = 2V_{cabezal} + V_{casco} \quad (18)$$

$$V_{mat} = 2 \frac{\pi D^2}{4} t_{cabezal} + \left[\frac{\pi D^2}{4} - \frac{\pi (D - 2t_{casco})^2}{4} \right] L_{tanque} \quad (19)$$

$$V_{mat} = \frac{\pi 0.5^2}{2} 0.0324 + \left[\frac{\pi 0.5^2}{4} - \frac{\pi (0.5 - 2 * 0.00635)^2}{4} \right] 0.73$$

$$\Rightarrow V_{mat} = 0.0199m^3$$

de la ecuación N° 17, el peso de la cámara vacía es:

$$W_{cam} = 7805.7 \frac{Kg}{m^3} * 0.0199m^3$$

$$W_{cam} = 155kg$$

a este valor se le suma el peso del refrigerante, resistencias y accesorios. Este valor se puede estimar en 20 kg (aproximadamente 45 lbs). Entonces el peso del tanque es 175 kg.

La fuerza que debe soportar la silleta es, del anexo:

$$F = K_{11}Q \quad (20)$$

donde:

K_{11} = constante que depende del ángulo de contacto, para un ángulo igual a 120° , K_{11} es 0.204.

Q = carga sobre la silleta, o sea, $175/2 = 87,5$ lbs.

Tenemos entonces:

$$F = 0.204 * 87,5kg.$$

$$\Rightarrow F = 17,85kg.$$

El material a utilizar para la silleta es el acero SA-283C, con un valor de esfuerzo de 12700 lb/pulg².

El espesor del alma de la silleta viene dado por la siguiente expresión:

$$t_{alma} = \frac{4.5F}{RS} \quad (21)$$

con $R = 0.25$ m, el radio del tanque.

$$t_{alma} = \frac{4.5 * 17,85kg.}{0.25m * 12700 \frac{lbs}{pulg^2} * \frac{8928983.66 \frac{kg}{m^2}}{1 \frac{lb}{pul^2}}}$$

$$\Rightarrow t_{alma} = 2,833 * 10^{-9} m$$

Este es un valor sumamente pequeño, lo cual quiere decir que cualquier espesor comercial sirve, por lo que se toma una placa de espesor 3 mm, e incluso puede ser de otro material con un valor de esfuerzo menor y mas barato.

En el plano M-04 esta representada la Cámara de destilación.

4.1.5 Selección de accesorios de la cámara de destilación.

El calor en la cámara lo van a suministrar cuatro resistencias de inmersión marca IES modelo CMAT-1007 con una capacidad de generar 3000 W cada una. Sus características pueden observarse en los anexos.

Tres niveles de pozo marca Inelce.

El nivel máximo de la cámara será controlado por dos bulbos, estos controlaran la válvula de expansión termostática. Las características de este dispositivo se muestran en los anexos.

4.2 Compresor.

Las especificaciones del compresor corresponden a las de los puntos (5) y (6) del diagrama de flujo de la figura N° 6. Para su cálculo, hay que tomar en cuenta que las capacidades que vienen en las tablas de compresores varían de acuerdo con el refrigerante para un mismo tipo de compresor fijando el desplazamiento volumétrico, por lo es necesario hacer un análisis de la capacidad de los compresores para los tres tipos de refrigerante para los que estamos trabajando, como lo son el R22, R12 y R134a.

Inicialmente, se calculó el desplazamiento volumétrico teórico del compresor para cada tipo de refrigerante, a una temperatura de evaporación de 10 °C mediante la siguiente ecuación:

$$Dvol_{teor} = \dot{m}_{ref} * v_{gcam} \quad (22)$$

donde:

$Dvol_{teor}$ = desplazamiento volumétrico teórico del compresor en (pie³/min).

\dot{m}_{ref} = tasa de flujo de refrigerante en (lb/min).

v_{gcam} = volumen específico del refrigerante en forma de vapor en la cámara en (pie³/lb).

Para el R22:

$$Dvol_{teor} = 488.89 \frac{lb}{hora} * 0.5548 \frac{pie^3}{lb}$$

$$\Rightarrow Dvol_{teor} = 271.24 \frac{pie^3}{hora} = 7.68 \frac{m^3}{hora}$$

Para el R134a:

$$Dvol_{teor} = 488.89 \frac{lb}{hora} * 0.7925 \frac{pie^3}{lb}$$

$$\Rightarrow Dvol_{teor} = 387.45 \frac{pie^3}{hora} = 10.97 \frac{m^3}{kg}$$

Para el para R12:

$$Dvol_{teor} = 488.89 \frac{lb}{hora} * 0.6621 \frac{pie^3}{lb}$$

$$\Rightarrow Dvol_{teor} = 323.69 \frac{pie^3}{hora} = 9.17 \frac{m^3}{kg}$$

Al comparar los tres resultados anteriores, se concluye que para una misma tasa de flujo de refrigerante, el compresor de R134a requiere desplazar mayor cantidad de refrigerante, es decir, este compresor debe ser mas grande que los compresores de R12 y R22, por lo tanto el compresor de R134a será nuestro patrón de trabajo.

Como el desplazamiento volumétrico del compresor es proporcional a su capacidad, entonces para un mismo desplazamiento volumétrico, el compresor de R134a va a dar una capacidad menor cuando utilice R22 y R12.

Para un valor de eficiencia volumétrica de 70 %, se tiene que:

$$Dvol_{real} = \frac{Dvol_{teor}}{n_{vol}}$$

$$Dvol_{real} = \frac{10.97 \frac{m^3}{hora}}{0.7}$$

$$\Rightarrow Dvol_{real} = 15.67 \frac{m^3}{hora}$$

La tabla N° 4 muestra las capacidades de los compresores marca Bitzer, para un desplazamiento volumétrico de 19 m³/h y temperatura de condensación igual a 50 °C:

Tabla N° 4. Capacidades del Compresor Bitzer.

Tevap (°C)	QR22 (Kcal/h)	QR12 (Kcal/h)	QR12/QR22
-5	9235	5840	0.632376827
-10	7500	4730	0.630666667
-15	6080	3755	0.617598684

La tabla N° 5 muestra las capacidades de los compresores marca Bock (ver anexo), para un desplazamiento volumétrico de 16.78 m³/h y temperatura de condensación igual a 50 °C:

Tabla N° 5. Capacidades del Compresor Bock.

Tevap (°C)	QR22 (Kw)	QR134a (Kw)	QR134a/QR22
10	17.4	11.66	0.670114943
5	14.7	9.6	0.653061224
0	12.2	7.8	0.639344262
-5	10.1	6.24	0.617821782
-10	8.2	4.91	0.598780488
-15	6.58	3.79	0.575987842

Para calcular la relación entre la capacidad del compresor usando R134a y usando R12, se divide:

$$\frac{\frac{Q_{R134a}}{Q_{R22}}}{\frac{Q_{R12}}{Q_{R22}}} = \frac{Q_{R134a}}{Q_{R12}}$$

entonces:

Tabla N° 6. Relación entre las capacidades de los compresores Bock y Bitzer.

Tevap (°C)	QR12/QR22	QR134a/QR22	QR134a/QR12
-5	0.632376827	0.617821782	0.976983589
-10	0.630666667	0.598780488	0.94944052
-15	0.617598684	0.575987842	0.932624788

de lo anterior se puede concluir:

$$\frac{Q_{R134a}}{Q_{R22}} = 0.67$$

$$\frac{Q_{R134a}}{Q_{R12}} = 0.97$$

$Q_{\text{evap}R134a} = 9.07 \text{ Kw}$, entonces del las tablas de capacidades del compresor marca Bock para R134a con una temperatura de evaporación igual a 10 °C. y temperatura de condensación igual a 50 °C. se seleccionó el modelo FX3, el cual tiene las siguientes características:

- Capacidad (\dot{Q}_o) = 9.34 Kw.
- Potencia en el eje (P_e) = 2.28 Kw.
- Velocidad del compresor (n) = 950 rpm.
- Desplazamiento volumétrico (\dot{V}_{th}) = 13.28 m³/h.
- Temperatura de succión (T_s) = 25 °C.

Con la capacidad del compresor, se recalcula la tasa de flujo de refrigerante:

$$\dot{m}_{ref} = \frac{\dot{Q}_o}{(h_{gcam} - h_{ft})} \quad (23)$$

$$\dot{m}_{ref} = \frac{9.34 \text{ Kw} * 3412 \frac{\text{Btu}}{\text{Kw} * \text{hora}} * \frac{1 \text{ kg}}{2.2 \text{ lb}}}{(110.058 - 46.725) \frac{\text{Btu}}{\text{lb}}}$$

$$\dot{m}_{ref} = 228.7 \frac{\text{kg}}{\text{hora}} = 503.14 \frac{\text{lb}}{\text{hora}}$$

este valor se puede aproximar a 500 lb/hora, entonces recalculando los valores de Q_{evap} para cada refrigerante se tiene:

Para R134a:

$$Q_{evapR134a} = 500 \frac{lb}{hora} * (110.058 - 46.725) \frac{Btu}{lb} * \frac{1Kw}{3412 \frac{Btu}{hr}}$$

$$\Rightarrow Q_{evapR134a} = 9.28Kw$$

Para R12:

$$Q_{evapR12} = 500 \frac{lb}{hora} * (82.927 - 32.474) \frac{Btu}{lb} * \frac{1Kw}{3412 \frac{Btu}{hr}}$$

$$\Rightarrow Q_{evapR12} = 7.39Kw$$

Para R22:

$$Q_{evapR22} = 500 \frac{lb}{hora} * (108.997 - 41.119) \frac{Btu}{lb} * \frac{1Kw}{3412 \frac{Btu}{hr}}$$

$$\Rightarrow Q_{evapR22} = 9.95Kw$$

La capacidad del compresor cuando utiliza R12 queda se determina como sigue:

$$Q_{R12} = \frac{Q_{R134a}}{0.97} = \frac{9.34Kw}{0.97}$$

$$\Rightarrow Q_{R12} = 9.63Kw$$

La capacidad del compresor cuando utiliza R22 se determina como sigue:

$$Q_{R22} = \frac{Q_{R134a}}{0.67} = \frac{9.34Kw}{0.67}$$

$$\Rightarrow Q_{R22} = 13.94Kw$$

La reducción de capacidad del compresor cuando utiliza R12 y R22 es:

$$Redq = \left(1 - \frac{Q_{evap}}{Capcomp}\right) * 100 \quad (24)$$

donde:

Capcomp = capacidad del compresor en (Kw).

Qevap = calor necesario para evaporar el refrigerante en (Kw).

Redq = reducción de capacidad del compresor en (%).

Para el R22:

$$Redq = \left(1 - \frac{9.95Kw}{13.94Kw}\right) * 100$$

$$\Rightarrow Redq = 28.6\%$$

Para el R12:

$$Redq = \left(1 - \frac{7.39Kw}{9.63Kw}\right) * 100$$

$$\Rightarrow Redq = 23.3\%$$

Esta pérdida de capacidad es inevitable si se requiere el uso de un solo compresor para los tres tipos de refrigerantes; sin embargo no afecta el proceso ya que la misma se produce solo cuando no existe flujo de refrigerante a la cámara de destilación.

Para el accionamiento del compresor, de las especificaciones del compresor marca Bock, se observa que este es accionado por 2 bandas en V que se colocan sobre una polea de doble ranura con un ancho de 12.7 milímetros (1/2 pulgada) y un ángulo de 38 °.

Las secciones de bandas en V se muestran en la siguiente tabla:

Tabla N° 7. Secciones de bandas en V normalizadas.

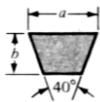

Sección	Ancho a, pulg.	Espesor b, pulg.	Mínimo Diámetro de polea, pulg.	Potencias para una o mas bandas, Hp.
A	1/2	11/32	3	1/4 a 100
B	21/32	7/16	5.4	1 a 25
C	7/8	17/32	9	15 a 100
D	1 1/4	3/4	13	50 a 250
E	1 1/2	1	21.6	100 o mayor

De la tabla anterior se observa que las correas que usa el compresor seleccionado es una de sección A.

Para especificar una banda en V, se indica la letra de sección de la banda, seguida de la circunferencia interior en pulgadas (las circunferencias normalizadas se muestran en la tabla N° 8).

Tabla N° 8. Circunferencias internas de bandas en V normalizadas.

SECCIÓN	CIRCUNFERENCIA, in
A	26, 31, 33, 35, 38, 42, 46, 48, 51, 53, 55, 57, 60, 62, 64, 66, 68, 71, 75, 78, 80, 85, 90, 96, 105, 112, 120, 128
B	35, 38, 42, 46, 48, 51, 53, 55, 57, 60, 62, 64, 65, 66, 68, 71, 75, 78, 79, 81, 83, 85, 90, 93, 97, 100, 103, 105, 112, 120, 128, 131, 136, 144, 158, 173, 180, 195, 210, 240, 270, 300
C	51, 60, 68, 75, 81, 85, 90, 96, 105, 112, 120, 128, 136, 144, 158, 162, 173, 180, 195, 210, 240, 270, 300, 330, 360, 390, 420
D	120, 128, 144, 158, 162, 173, 180, 195, 210, 240, 270, 300, 330, 360, 390, 420, 480, 540, 600, 660
E	180, 195, 210, 240, 270, 300, 330, 360, 390, 420, 480, 540, 600, 660

El cálculo de la longitud de la banda se basa en la longitud de paso. Para determinada sección de banda, la longitud mencionada se obtiene agregando una cantidad a la circunferencia interior de la banda (tablas N° 8 y N° 9).

Tabla N° 9. Conversiones de longitud de banda.

Sección de banda	A	B	C	D	E
Cantidad a sumar	1.3	1.8	2.9	3.3	4.5

La longitud de paso de una banda en V viene dada por la ecuación:

$$L_p = 2C + 1.57(D + d) + \frac{(D - d)^2}{4C} \quad (25)$$

donde:

C = distancia entre centros.

D = diámetro de paso de la polea mayor.

d = diámetro de paso de la polea menor.

L_p = longitud de paso de la banda.

El cálculo del diámetro de paso de la polea menor esta dado por la siguiente ecuación:

$$d = D \frac{n_1}{n_2} \quad (26)$$

donde:

n_1 = revoluciones de la polea mayor.

n_2 = revoluciones de la polea menor.

El diámetro de la polea mayor es igual a el diámetro de la polea del compresor, cuyo valor es de 210 mm y tiene una velocidad de 950 rpm.

Las revoluciones de la polea menor son las del motor eléctrico, si se toman como 1750 rpm, el diámetro de la polea menor es, de la ecuación N° 26 :

$$d = 210 \frac{950}{1750}$$
$$\Rightarrow d = 114mm$$

Si la distancia entre centros es 300 mm, entonces la longitud de paso de la correa es, de la ecuación N° 25:

$$L_p = 2 * 300 + 1.57(210 + 114) + \frac{(210 - 114)^2}{4 * 500}$$

$$\Rightarrow L_p = 1113.3mm$$

llevando esto a pulgadas:

$$\Rightarrow L_p = 43,83 pulg$$

Tomando una valor nominal de longitud de circunferencia interna de la banda igual a 46 pulgadas, entonces de la tabla N° 9, se obtiene que la longitud de paso es de 47,3 pulgadas. La nueva distancia entre centros es de 327 mm.

Para mover al compresor, se utilizará un motor eléctrico con una velocidad de 1750 rpm y una potencia mayor de 2.3 Kw.

Por lo tanto, se selecciono un motor marca Siemens modelo 1LA5 111-4YB60 cuyas especificaciones técnicas son las siguientes:

- Velocidad = 1800 rpm (4 polos).
- Potencia = 3 Kw.
- Intensidad de corriente nominal = 13,5 A.
- Voltaje = 220 V. Trifásico.
- El tipo de arranque es directo.
- Factor de potencia = 1.15.

El aumento de velocidad de 1750 a 1800 rpm no representa ningún inconveniente, ya que lo único que acarrea es que el compresor aumente su capacidad.

4.3 Condensador.

Las condiciones del condensador corresponden a las condiciones entre los puntos (6) y (7) del diagrama de flujo de la figura N° 1. La capacidad del condensador esta basada en el calor total rechazado del sistema, el cual es la suma del calor necesario para evaporar el refrigerante en la cámara de destilación y el calor de compresión añadido al mismo por el compresor. Lo anterior queda representado en la siguiente ecuación:

$$Q_{\text{cond}} = Q_{\text{evap}} + Q_{\text{comp}} \quad (27)$$

donde:

Q_{evap} = calor necesario para evaporar el refrigerante en (Kw).

Q_{comp} = calor de compresión en (Kw).

Como el refrigerante mas critico desde el punto de vista térmico, es el R22 (tiene un Q_{evap} . mayor), la capacidad del condensador se calcula para el R22.

El calor de compresión viene siendo la potencia en el eje del compresor multiplicado por un factor que me lleve ese valor a Kw. En nuestro caso, como en las tablas de capacidad del compresor la potencia en el eje viene en Kw, no hay que utilizar ningún factor de conversión. Para el cálculo de la potencia en el eje (Pe), se utilizo un análisis similar al realizado para el cálculo del compresor tomando en cuenta que la capacidad del compresor es proporcional a la potencia en el eje:

$$\frac{Pe_{R134a}}{Pe_{R22}} = 0.67 \quad (28)$$

de donde se despeja la potencia en el eje para R22, entonces:

$$Pe_{R22} = \frac{Pe_{R134a}}{0.67} = \frac{2.28Kw}{0.67}$$

$$\Rightarrow Pe_{R22} = 3.4Kw$$

entonces la capacidad del condensador queda:

$$Q_{cond} = 9.95 Kw + 3.4 Kw$$

$$\Rightarrow Q_{cond} = 13.35 Kw$$

La temperatura de condensación se calcula a través de la siguiente ecuación:

$$T_{cond} = TBS_{aire} + DT \quad (29)$$

donde:

T_{cond} = temperatura de condensación del refrigerante.

TBS_{aire} = temperatura de bulbo seco del aire exterior.

DT = diferencia de entre la temperatura del aire exterior y la temperatura de condensación.

De lo anterior, el condensador se selecciona con los siguientes parámetros:

Capacidad = 13.35 Kw.

$$TBS_{\text{aire}} = 40 \text{ }^{\circ}\text{C}.$$

$$DT = 10 \text{ }^{\circ}\text{C}.$$

De la ecuación N° 29:

$$T_{\text{cond}} = 40 \text{ }^{\circ}\text{C} + 10 \text{ }^{\circ}\text{C} = 50 \text{ }^{\circ}\text{C}.$$

Hay que tomar en cuenta que:

$$Q_{\text{tabla}} \geq Q_{\text{cond}} * F_{\text{corr}} \quad (30)$$

de la tabla de capacidades del condensador (ver anexo), para una temperatura de condensación igual a 50 °C (122 °F) y una temperatura de evaporación de 10 °C (50 °F), se obtiene un factor de corrección (Fcorr) igual a 1.178.

Entonces el valor de capacidad de la tabla (Q_{tabla}) es:

$$Q_{\text{tabla}} \geq 13.35 * 1.178 = 15.73 \text{ Kw}$$

Para entrar a las tablas de capacidades la diferencia de temperatura TD debe estar en °F y Q_{tabla} en Btu/hora, por lo tanto tenemos:

$$TD = (10 \text{ }^{\circ}\text{C}) * 1.8 = 18 \text{ }^{\circ}\text{F}.$$

$$Q_{\text{tabla}} = 15.73 \text{ Kw} * 3412 \text{ Btu/hr} * \text{Kw} = 53671 \text{ Btu/hora}.$$

Entonces se selecciona el condensador tamaño 006 (con un subenfriamiento de 5 °F y un circuito) de la marca Carrier modelo 09AWV006, cuyas características son:

- Capacidad = 66280 Btu/hora = 19.43Kw.
- Voltaje = 208/230 V-60Hz.

- Numero de ventiladores = 2.
- Velocidad de los ventiladores = 1140 rpm.
- Potencia del motor de cada ventilador = 1/2 Hp.

En los planos M-01 y M-02 se aprecia el sistema en conjunto y la proyección ortogonal del mismo respectivamente.

4.4 Estructura.

La estructura esta constituida en su totalidad de perfiles angulares Sidor L50x50x4 y L 35x35x4. Para la unión de los mismos se ha empleado soldadura manual al arco de 4 mm de espesor y electrodos del tipo E-6013. Véase plano M-03.

CAPITULO 5. CALCULO DE TUBERÍAS Y SELECCIÓN DE ACCESORIOS.

5.1 Líneas de refrigerante.

Para la determinación de las líneas de refrigerantes nos basamos en el método de calculo contemplado en el manual del ASHRAE. En este mediante el uso de tablas construidas para ciertas condiciones de funcionamiento y formulas para equivalencias con otras condiciones, se determinan las dimensiones de las líneas de liquido, succión y descarga de un equipo de refrigeración o acondicionamiento de aire. Considerando que nuestro sistema de regeneración presenta condiciones de funcionamiento similares a las de estos equipos, los métodos de dimensionamiento de las líneas de refrigerante se pueden utilizar sin ningún inconveniente.

Las tablas utilizadas están basadas en la relación de Darcy-Weisbach y los factores de fricción han sido calculados tomando una rugosidad del cobre de 0,000005 ft. También las perdidas por accesorios han sido tomadas del ASHRAE.

Si los parámetros de diseño no están contemplados en la tabla se utilizan las siguientes formulas de equivalencia:

$$\Delta T = \Delta T_{\text{tabla}} * \left(\frac{L_{e_real}}{L_{e_tabla}} \right) * \left(\frac{\text{Capacidad}_{\text{real}}}{\text{Capacidad}_{\text{tabla}}} \right)^{1,8} \quad (31)$$

$$\text{Capacidad}_{\text{real}} = \text{Capacidad}_{\text{tabla}} * \left(\frac{L_{\text{etabla}} * \Delta T_{\text{real}}}{L_{\text{ereal}} * \Delta T_{\text{tabla}}} \right)^{0,55} \quad (32)$$

Tabla N°10. Líneas de succión, descarga y liquido para refrigerante R22.

Tamaño de la línea Tubo de Cobre tipo L Diám. Externo	Línea de succión (DT=2°F)					Línea de descarga		Línea de liquido
	Temperatura de saturación en succión, °F					(DT= 1°F, DP= 3,05 psi)		DT=1°F, DP=3,05psi
	-40	-20	0	20	40	Temperatura de saturación en la succión, °F		
	DP correspondiente, psi/100ft.							
	0,79	1,15	1,6	2,22	2,91	-40	40	
1/2	-	-	-	0,4	0,6	0,75	0,85	3,6
5/8	-	0,32	0,51	0,76	1,1	1,4	1,6	6,7
7/8	0,52	0,86	1,3	2	2,9	3,7	4,2	18,2
1-1/8	1,1	1,7	2,7	4	5,8	7,5	8,5	37
1-3/8	1,9	3,1	4,7	7	10,1	13,1	14,8	64,7
1-5/8	3	4,8	7,5	11,1	16	20,7	23,4	102,5
2-1/8	6,2	10	15,6	23,1	33,1	42,8	48,5	213
2-5/8	10,9	17,8	27,5	40,8	58,3	75,4	85,4	376,9
3-1/8	17,5	28,4	44	65	92,9	120,2	136,2	601,5
3-5/8	26	42,3	65,4	96,6	137,8	178,4	202,1	895,7
4-1/8	36,8	59,6	92,2	136,3	194,3	251,1	284,4	1263,2

DP = caída de presión debido a la fricción en la línea, psi por 100 ft de longitud equivalente.

DT = cambio en la temperatura de saturación, °F por 100 ft de longitud equivalente.

Las capacidades están dadas en ton. de refrigeración.

Para el calculo de las líneas se tomo como refrigerante patrón el R22 por ser este el que presenta mayor caída de presión en las líneas.

Por otra parte debemos tomar en consideración como parámetro el rango de velocidades permitidas en las líneas. Estos están contemplados en la tabla siguiente:

Tabla N° 11. Rango de velocidades en las líneas.

Línea	Velocidad mínima(fpm)	Velocidad máxima(fpm)
Succión	900	4000
Descarga	2000	3500
Liquido	-----	300

Estos rangos de velocidades han sido determinados para los equipos de refrigeración y aire acondicionado de manera que aseguren el retorno del aceite al compresor. Para nuestro sistema esto no es un inconveniente ya que este se encarga de eliminar el aceite del refrigerante contaminado, sin embargo los hemos tomado como patrones para el dimensionamiento de nuestro sistema.

5.2 Dimensionamiento de la línea de liquido entre el recipiente contenedor y la cámara de destilación.

Estos cálculos obedecen a las condiciones entre los puntos (1) y (2) de la figura N° 1. En el diseño de esta línea se debe asegurar que no ocurra cambio de fase en la misma. Los sistemas de refrigeración y aire acondicionado son diseñados de manera que la caída de presión en la línea de liquido corresponda a un cambio en la temperatura de saturación entre 1 y 2 °F. Como punto de referencia para los cálculos de esta se tiene que la caída de presión en la línea de liquido para un cambio en la temperatura de saturación de 1 °F a una temperatura de condensación de 100 °F son aproximadamente:

Tabla N° 12. Caída de presión en la línea de liquido.

<i>Refrigerante</i>	<i>ΔP(psi)</i>
R22	2,9
R134a	2,1

Parámetros a considerar:

- $\dot{m} = 504 \text{ lbm/h} = 0,14 \text{ lbm/s}$
- $D_{\text{nominal}} = 5/8 \text{ pulg.}$
- Velocidad en la línea $< 300 \text{ fpm.}$
- $\rho_{(T=50^{\circ}\text{F})} = 0,04067 \text{ lbm/pulg.}^3$
- Temperatura de evaporación de 50°F
- Temperatura de condensación de 122°F
- Capacidad_{real} = 3 ton de refrigeración.
- Longitud de la línea de $2\text{m} = 6,56 \text{ ft.}$
- 2 codo de $90^{\circ} = 4 \text{ ft.}$
- 1 válvula check = 8 ft.
- 1 válvula solenoide = 8 ft.
- 1 filtro de partículas sólidas = 1 psi
- 1 válvula termostática = 8 ft.
- $L_{\text{e_real}} = 6,56 + 4 + 8 + 8 + 8 = 34,56 \text{ ft.}$

De la formula:

$$\dot{m} = \rho * U * A \quad (33)$$

se obtiene un valor de $U = 11,22 \text{ pulg/s} = 56,119 \text{ fpm.}$

De la tabla N° 10 se tiene:

Para un diámetro de tubería de 5/8 pulg.

- $\Delta T_{\text{tabla}} = 1 \text{ } ^\circ\text{F}$
- $\Delta P = 3,05 \text{ psi}$
- Capacidad_{tabla} = 6,7 ton de refrigeración.

Utilizando la formula N° 31 se obtiene:

$$\Delta T = 0,0813 \text{ } ^\circ\text{F.}$$

Considerando la tabla N° 12 las perdidas por fricción se calculan de la siguiente forma:

$$0,0813 * 2,9 * (122/100) = 0,29 \text{ psi}$$

Con este valor y considerando las perdidas debida a los filtros se tiene una caída de presión total en la línea igual a:

$$\Delta P_{\text{total}} = 0,29 + 1 + 1 = 2,29 \text{ psi.}$$

Luego la presión en la válvula de expansión será:

$$222,56 - 2,29 \text{ psi} = 220,27 \text{ psi}$$

A este valor de presión le corresponde una temperatura de saturación de 104 °F por lo que no se tendrá problema alguno en esta línea. Estos resultados pueden ser extrapolados sin temor a cometer un error significativo para el dimensionamiento de la línea de líquido entre el condensador y el recipiente receptor de refrigerante regenerado.

5.3 Dimensionamiento de la línea de succión.

Estos cálculos condicionan el tramo entre los puntos (3) y (4) representados en la figura N° 1. En el dimensionamiento de esta línea para un sistema de refrigeración o aire acondicionado se debe procurar la menor caída de presión, ya que un alto valor de esta disminuiría la presión de succión del compresor aumentando la relación de compresión y en consecuencia el trabajo del compresor. En nuestro caso solo se presentara este inconveniente cuando no haya flujo de refrigerante contaminado hacia la cámara de destilación, esto solo sucederá cuando se acabe el refrigerante en el recipiente contenedor lo que acarrea un aumento en el trabajo del compresor por poco tiempo esto se traducirá en un desperdicio de energía. Por otro en la mayor parte del proceso habrá presión positiva y bastante mayor que en la succión del compresor en la cámara de destilación.

Para esta línea y una temperatura de saturación en la succión de 40 °F se tienen la caída de presión.

Tabla N° 13. Caída de presión en la línea de succión.

<i>Refrigerante</i>	<i>ΔP(psi)</i>
R22	2,91
R134a	1,93

Para el sistema tenemos los siguientes parámetros:

- $\dot{m} = 504 \text{ lbm/h}$
- $D_{\text{nominal}} = 1 \frac{1}{8} \text{ pulg.}$
- Velocidad en la línea $900 \text{ fpm} < V < 4000 \text{ fpm.}$
- $\rho_{(T=50^{\circ}\text{F})} = 0,0010428 \text{ lbm/pulg.}^3$
- Temperatura de evaporación de 50°F.
- Temperatura de condensación de 122°F.
- Capacidad_{real} = 3 ton de refrigeración.
- 1 filtro secador = 1 psi
- Longitud de la línea de $1,5 \text{ m} = 4,92 \text{ ft.}$
- 4 codo de $90^{\circ} = 8 \text{ ft.}$
- 1 válvula solenoide = 8 ft.
- $L_{e_real} = 4,92 + 8 + 8 = 20,92$

De la formula N° 33 se obtiene un valor de:

$$U = 437,6 \text{ pulg/s} = 2188 \text{ fpm.}$$

De las tabla N° 10 se tiene:

Para un diámetro de tubería de $1 \frac{1}{8} \text{ pulg.}$

- $\Delta T_{\text{tabla}} = 2 \text{ } ^\circ\text{F}$
- $\Delta P = 2,91 \text{ psi}$
- Capacidad_{tabla} = 5,8 ton de refrigeración.

Utilizando la formula N° 31 se obtiene:

$$\Delta T = 0,13 \text{ } ^\circ\text{F}.$$

Considerando la tabla N° 13 las perdidas por fricción se calculan de la siguiente forma:

$$0,13 * 2,91 * (50/40) = 0,5 \text{ psi}.$$

Luego el valor de la caída de presión en la succión es:

$$\Delta P_{\text{total}} = 0,5 + 1 = 1,5 \text{ psi}$$

5.4 Dimensionamiento de la línea de descarga.

Estos cálculos condicionan el tramo entre los puntos (5) y (6) representados en la figura N° 1. En esta línea se tiene como referencia que la caída de presión corresponda a una variación de temperatura entre 1 y 2 °F.

Para el dimensionamiento de esta línea se consideraron los siguientes parámetros:

- $\dot{m} = 504 \text{ lbm/h}$
- $D_{\text{nominal}} = 7/8 \text{ pulg.}$
- Velocidad en la línea $2000 < V < 3500 \text{ fpm.}$
- $\rho_{(T=122^{\circ}\text{F})} = 0,0031 \text{ lbm/pulg.}^3$
- Temperatura de evaporación de 50°F.
- Temperatura de condensación de 122°F.
- Capacidad del equipo de 3 ton de refrigeración.
- Longitud de la línea de $2 \text{ m} = 6,56 \text{ ft.}$
- 3 codo de $90^{\circ} = 6 \text{ ft.}$
- 1 válvula solenoide = 8 ft.
- 1 válvula check = 8 ft.
- 1 Filtro separador de aceite = 1 psi
- $L_{e_real} = 6,56 + 6 + 8 + 8 = 28,56$

De la formula N° 33 se obtiene:

$$U = 230 \text{ pulg/s} = 1150 \text{ fpm.}$$

De la tabla N° 10 se tiene:

Para un diámetro de tubería de $7/8 \text{ pulg.}$

- $\Delta T_{\text{tabla}} = 1 \text{ }^\circ\text{F}$
- $\Delta P = 3,05 \text{ psi}$
- Capacidad_{tabla} = 4,2 ton de refrigeración.

Utilizando la formula N° 31 se obtiene:

$$\Delta T = 0,16 \text{ }^\circ\text{F.}$$

5.5 Válvulas.

5.5.1 Selección de la válvula para el control de flujo hacia la cámara de destilación.

Para la alimentación de refrigerante a la cámara de destilación se opto por el uso de una válvula de expansión termostática equipada con un controlador de nivel del tipo capacitivo (bulbo). El bulbo se instalara en la cámara de destilación de manera de controlar el nivel máximo de refrigerante dentro de la misma.

Esta válvula se determina mediante los datos de capacidad del sistema y la diferencia entre las presiones que se requieren.

Tabla N° 14. Caída de presión de la Válvula Termostática.

Presión (psia)	R22	R134a	R12
P_{tanque}	225,53	149,63	141,01
$P_{\text{evaporador}}$	98,8	60,116	61,316
ΔP	126,73	89,514	79,694

Con los datos de la tabla vamos a el catalogo anexo de LMC y obtenemos:

- Para R22 con $\Delta P = 125$ psia una válvula LMC del tipo P-H, la cual tiene una capacidad nominal de 5 ½ ton de refrigeración.
- Para R12 y R134a con una $\Delta P = 80$ psia una válvula LMC del tipo P-H, la cual tiene una capacidad nominal de 4 ton de refrigeración.

5.5.2 Selección de la válvulas solenoide.

Para la selección de esta válvula se necesita la capacidad del sistema. Por esto para nuestro sistema se opto por:

- 3 Válvulas de la casa Parker modelo S81 para un tamaño de puerto de 3/8 de pulgada, la cual tiene una capacidad nominal de 6 ton de refrigeración. Esta válvula da la misma caída de presión para el R12, R22 y R134a.

5.5.3 Selección de la válvula check.

Se recomienda el uso de una válvula check que cumpla con los requerimientos del sistema en lo que a capacidad. Una opción es la válvula check tipo *Copper Ball Check Valve* de la casa Parker modelo CV7-10FS-10FS.

5.6 Separadores de aceite.

Estos filtros tienen la finalidad de proteger al sistema de aceite contaminado con partículas sólidas, ácidos y humedad. Estos filtros se seleccionan según la capacidad del sistema, por esto se debe escoger un filtro para una capacidad de 3 ton o mayor ya que el sistema funciona con refrigerantes contaminados. De la casa Parker se selecciono el modelo POS-321.

5.7 Filtros Secadores.

Estos filtros tienen la función de absorber la humedad presente en el sistema así como ácidos y partículas sólidas. Para la selección de estos filtros se debe tomar en consideración el tipo de sistema, las dimensiones de las líneas, la capacidad de flujo, material de construcción, capacidad de filtración.

Para el sistema tomando en cuenta parámetros como:

- Se va a trabajar con refrigerante contaminado, lo que conlleva a unas condiciones de trabajo especiales.
- Las presiones de trabajo son mayores que las presentadas en un equipo de refrigeración o aire acondicionado convencional.

Por todo lo expuesto anteriormente se opto por los modelos P485, P487 y P489 con elemento filtrante del tipo PCK-48HH de la casa Parker.

5.8 Visores de liquido.

Para la adquisición de los visores de liquido solo se necesita el diámetro de la línea. Para el sistema tenemos un diámetro de línea de liquido de 5/8 de pulgada, por lo que se seleccionan los visores Parker modelo PSG-5

CAPITULO 6. ESTRATEGIAS DE CONTROL Y AUTOMATIZACIÓN DEL SISTEMA.

6.1 Sistema básico de control.

El sistema de regeneración será controlado mediante un PLC, el cual se encargará de los siguientes dispositivos:

- 2 válvula de control termostatica con bulbo para control de nivel.
- 4 resistencias eléctricas.
- 4 dispositivos para el control de nivel del tipo capacitivo.
- 4 válvulas solenoide.
- Motor eléctrico y condensador

6.2 Lógica de funcionamiento.

El funcionamiento del sistema de regeneración obedece a la siguiente lógica de funcionamiento:

Para el control del nivel máximo de llenado de la cámara de destilación se utilizara una válvula de expansión termostática que consta de un bulbo sensor de nivel. Este bulbo accionara la válvula cuando cambie su temperatura debido al contacto con el refrigerante liquido. La válvula de expansión termostatica esta normalmente abierta (N.O), de allí cuando el bulbo de control de nivel de la válvula sense el nivel la misma se cerrara. Al sensar nivel el dispositivo energiza los contactores de las resistencias, encendiéndolas. El dispositivo de control de más bajo nivel se encargara de gobernar tanto la resistencia asociada a él, como al motor que activa el compresor y el ventilador

del condensador. Este lazo se mantendrá mientras permanezca lleno hasta su máximo nivel la cámara de destilación.

Cuando ya no exista alimentación del recipiente contenedor de refrigerante, comenzara el descenso del nivel del tanque; a medida que los sensores asociados a cada una de las resistencias dejen de sensar nivel desenergizaran su respectiva resistencia y por ultimo se desenergizara el motor del compresor y del ventilador del condensador dando por terminado el ciclo de regeneración.

6.3 Selección de los dispositivos de control.

Para la selección de los elementos de control se tomaron en consideración los siguientes parámetros:

- Tipo de corriente (AC, DC), tensión y frecuencia de alimentación de la bobina.
- Tensión nominal de la carga.
- Tipo de maniobra a realizar.
- Frecuencia de maniobras.
- Categoría de empleo o carga a manejar.

En la siguiente tabla se muestran la categoría de los contactores según la aplicación en corriente alterna.

Tabla N° 16. Categorías de los contactores según la aplicación.

<i>Aplicaciones</i>	<i>Categorías</i>	<i>Cierre</i>			<i>Corte</i>		
		<i>I</i>	<i>V</i>	<i>F</i>	<i>I</i>	<i>V</i>	<i>F</i>
<i>Resistencias</i>	AC1	In	Vn	> 0,95	In	Vn	> 0,95
<i>Motor de rotor devanado</i>							
<i>Corte en marcha</i>	AC2	2,5 In	Vn	0,65	In	0-1 Vn	0,65
<i>Corte en arranque</i>	AC2	2,5 In	Vn	0,65	2,5 In	Vn	0,65
<i>Motor jaula de ardilla</i>							
<i>Corte en marcha</i>	AC3	6 In	Vn	0,35	In	0,2 Vn	0,35
<i>Corte en arranque</i>	AC4	6 In	Vn	0,35	6 In	Vn	0,35

6.3.1 Para las resistencias eléctricas.

La variación entre el estado frío y el caliente es de tal magnitud que la corriente de punta (I_p) no excede nunca de 2 a 3 veces la corriente nominal (I_n). Como raramente se producirán sobrecargas esta solo pueden protegerse contra cortocircuito; se requieren pocas maniobras, se interrumpen a corriente nominal y su factor de potencia (F) es muy cercano a la unidad.

Para la selección consideraron los siguientes parámetros:

- Voltaje = 220 V trifásico.
- Potencia = 3000 W
- $F = 0,95 = \cos \theta$
- $I_p = 3 I_n$.

Luego de la formula:

$$I_n = \frac{W}{V * \sqrt{3} * \cos \theta} \quad (34)$$

se tiene que $I_n = 8,3 \text{ A}$.

Con este valor de I_n vamos a la tabla de contactores Siemens y seleccionamos un contactor modelo 3RT1015-1AN21 el cual soporta en categoría AC1 una corriente nominal de 18 A.

6.3.2 Para el motor.

Para la selección consideraron los siguientes parámetros:

- Voltaje = 220 V trifásico.
- Potencia = 5 Hp = 3728,5 W.

Mediante la formula N° 34 se obtiene:

$$I_n = 10.31 \text{ A}.$$

Con estos datos se selecciono un contactor 3RT1025-1AN24, el cual soporta en categoría AC3 una corriente nominal de 17 A.

Se selecciono un contactor categoría AC3, debido a que este es el que se utiliza con motores del tipo jaula de ardilla (motores de rotor en cortocircuito). En el arranque el contactor debe poder establecer la corriente de arranque, del orden de 5 a 7 veces la corriente nominal del motor. Al abrir, el contactor debe poder cortar la corriente nominal del motor bajo una tensión del orden del 20% de la tensión de la red.

6.4 Selección de conductores.

Los conductores son seleccionados de acuerdo al amperaje que circula a través de ellos, por lo tanto tenemos:

Para la alimentación del motor, con la intensidad de 17 amperios se selecciona el conductor TW calibre 12 que soporta una intensidad de 25 amperios.

Para la alimentación de resistencias se selecciona el conductor TW calibre 12.

Para los demás dispositivos, como las válvulas solenoides, controladores de nivel y entradas salidas del PLC se selecciona conductores TW calibre 14.

Todos los conductores van a través de conduits de media pulgada de diámetro.

6.5 Selección del PLC.

Debido a las exigencias de nuestro automatismo, se debe seleccionar un PLC que cumpla con los requerimientos expuestos en el diagrama de control del sistema, una opción es el modelo TSX Nano 24 I/O del grupo Schneider.

6.6 Diagrama de control del sistema.

A continuación se muestra el diagrama escalera del sistema.

Figura N° 5. Diagrama de control del Sistema.

Leyenda.

VS1 = válvula solenoide de la línea de liquido 1.

VS2 = válvula solenoide de la línea de liquido 2.

VS3 = válvula solenoide de la línea de succión del compresor.

VS4 = válvula solenoide a la salida del condensador.

A = arranque del sistema.

LM1 = válvula termostática de control de nivel 1.

LM2 = válvula termostática de control de nivel 2.

LC1 = controlador de nivel 1.

LC2 = controlador de nivel 2.

LC3 = controlador de nivel 3.

R1= Contactor de resistencia eléctrica 1.

R2= Contactor de resistencia eléctrica 2.

R3= Contactor de resistencia eléctrica 3.

R4= Contactor de resistencia eléctrica 4.

1M = Contactor de arranque del motor.

2M = Contactor de arranque del condensador.

Res1 = Resistencia eléctrica 1.

Res2 = Resistencia eléctrica 2.

Res3 = Resistencia eléctrica 3.

Res4 = Resistencia eléctrica 4.

CAPITULO 7. ANÁLISIS ECONÓMICO DEL SISTEMA.

Este análisis hace una comparación de costos entre regenerar, comprar refrigerante nuevo y reconvertir los sistemas para la utilización de las nuevas generaciones de refrigerantes “ecológicos”.

Como primer argumento a favor de la regeneración vale decir que una de las medidas para la que los entes involucrados regeneren los refrigerantes es el alza en los precios de los mismos.

Existen algunos sistemas cuya reconversión es simplemente insostenible económicamente hablando, esto se refiere a la magnitud de los equipos.

Por otra parte la medida gubernamental de fijación de precios es la siguiente:

- El refrigerante contaminado se compra al 15% del valor del refrigerante nuevo.
- El refrigerante regenerado se vende al 75% del valor del refrigerante nuevo.

Este análisis pretendía establecer además una comparación de costos entre el sistema de regeneración que se encuentra en estos momentos en el país y el sistema de regeneración que ha sido diseñado. El análisis comparativo de costos fue imposible de realizar debido a que el sistema de regeneración existente en el país fue donado por la UNOPS por lo que no se tiene información acerca del precio del equipo; por otra parte existen diferencias significativas que hacen poco consistente una comparación entre ambas maquinas. Sin embargo se pueden realizar una comparación cualitativa entre ambos sistemas de manera de tener una visión de la capacidad de servicio de ambas maquinas.

7.1 Comparación cualitativa entre el sistema de regeneración existente en el país y el sistema diseñado.

- El sistema de regeneración existente en el país ha sido diseñado para una capacidad de producción de 800 ton. métricas al año; la capacidad del nuestro es de 400 ton. métricas al año.

- El sistema de regeneración existente en el país puede regenerar refrigerantes de baja, mediana y alta presión; el nuestro ha sido diseñado para la regeneración de refrigerantes de mediana y alta presión.
- El sistema de regeneración existente en el país usa como medio para el calentamiento del refrigerante en la cámara de destilación una mezcla de agua y glicol por lo que amerita un sistema de bombeo y un sistema de precalentamiento para este fluido (caldera); el sistema nuestro utiliza resistencias eléctricas para el calentamiento del refrigerante, esto lo hace más compacto.
- El sistema de regeneración existente en el país no es portátil, luego para la regeneración es indispensable trasladar el refrigerante al sitio donde se encuentra el equipo; nuestro sistema es un equipo portátil por lo que se puede realizar la regeneración en el sitio o lugar donde se amerite.
- El sistema de regeneración existente en el país ha sido concebido con tecnología extranjera, lo que conlleva a que muchos sino todos los equipos que la conforman, tengan poco o ningún mercado en nuestro país, esto puede significar un incremento en los costos de mantenimiento y reparación, de la misma; el sistema nuestro ha sido diseñado con productos existentes en el nuestro mercado.

CAPITULO 8. MANUAL DE FUNCIONAMIENTO.

Antes de iniciar cualquier sesión de regeneración de refrigerante se deben asegurar o cumplir las siguientes condiciones:

- Verificar que todas las válvulas en el sistema estén en posición correcta.

<i>Válvula</i>	<i>Posición</i>
Válvula Solenoide de línea de liquido 1 y 2	Normalmente Cerrada
Válvula Termostática	Normalmente Abierta
Válvula Solenoide de línea de succión	Normalmente Cerrada
Válvulas de servicio del compresor	Abierta
Válvula solenoide de la línea de descarga del condensador	Normalmente Cerrada
Válvulas de servicio de la cámara de destilación	Abierta

- Asegurarse de que el botón principal del panel de control se encuentra en la posición OFF.
- Verificar que el nivel de aceite del compresor es el indicado para su funcionamiento

8.1 Procedimiento de inicio del proceso de regeneración.

- Conecte el sistema a la toma de energía.
- Conecte el recipiente de refrigerante regenerado a la línea de descarga del condensador. Este recipiente de tener un vacío de aproximadamente 400μ.
- Conecte el recipiente de refrigerante contaminado a la línea de liquido 1 o 2, dependiendo del tipo de refrigerante que se este regenerando.
- Lleve el botón principal del panel de control a la posición ON.

- Abra las válvulas tanto del recipiente contaminado como la del recipiente de refrigerante regenerado.

8.2 Mantenimiento de la unidad.

- Después de periodos largos de regeneración, debe verificarse que el nivel de aceite sea el adecuado.
- Se recomienda que todos los filtros sean reemplazados cada vez que se hayan regenerado entre 3.000 y 4.000 libras de refrigerante.
- Para cambios de refrigerante se debe realizar un buen vacío al sistema (aproximadamente 400 μ), para así garantizar que no queden restos de refrigerante en el mismo, y con esto evitar una posible mezcla de refrigerantes.

8.3 Medidas de seguridad.

La medida de seguridad más importante con respecto a la operación del sistema de regeneración es asegurarse que las válvulas estén en la posición correcta para el tipo de refrigerante que se esté procesando.

También se debe asegurar una buena conexión de los recipientes a las líneas correspondientes a cada uno de ellos.

CAPITULO 9. CONCLUSIONES.

Una vez obtenidos los resultados del diseño de un Sistema de Regeneración para refrigerantes de alta y mediana presión se llegaron a las siguientes conclusiones:

- Para obtener una separación óptima entre el refrigerante y los agentes contaminantes el método a utilizar es la Destilación simple o flash.
- Se puede utilizar como sistema de calentamiento en la Cámara de Destilación resistencias eléctricas en vez de un intercambiador de calor como el del sistema original.
- La reducción de capacidad del compresor al cambiar de refrigerante 134a a refrigerante 12 y 22 es de 24% y 29% respectivamente.
- Las pérdidas en las tuberías son despreciables, esto se debe a la poca distancia existente entre los equipos que conforman el sistema.
- Es factible construir una Máquina de Regeneración para refrigerantes de alta y mediana presión en Venezuela.

CAPITULO 10. RECOMENDACIONES.

Tomando en cuenta los resultados obtenidos se recomienda:

- Realizar pruebas pilotos con el sistema diseñado para verificar los resultados teóricos obtenidos.
- Con la construcción de este Sistema se puede ampliar la funcionalidad del Programa de Recuperación y Regeneración de Refrigerantes a nivel nacional.
- Realizar una campaña de concientización acerca de los problemas ocasionados por la emisión de refrigerantes a la atmósfera, con el fin de involucrar a los consumidores de refrigerantes (Industrias, Empresas de Mantenimiento, etc) para que los reutilicen y con esto impulsar la regeneración en el país.
- Realizar estudios similares para refrigerantes de baja presión.

BIBLIOGRAFÍA

- 📖 **Dossat, Roy J.** “Principios de Refrigeración”. Décima Octava Edición, México, 1998. 594 pág.
- 📖 **ASHRAE Handbook.** “Refrigeration”. 1998.
- 📖 **ASHRAE Handbook.** “Fundamentals”. 1997.
- 📖 **ASHRAE Handbook.** “HVAC Systems and Equipment”. 1996.
- 📖 **ASHRAE Handbook.** “HVAC Applications”. 1995.
- 📖 **Shigley, Joseph E.** “Diseño en Ingeniería Mecánica”. Quinta Edición, México, 1990. 883 pág.
- 📖 **Protocol Resource Management Inc.** Manual de Operaciones e Instrucciones para la Planta de recuperación de Refrigerantes. 100 pág.
- 📖 **Hans, Garcia.** “Concepción de un Automatismo”. Caracas, 78 pág.
- 📖 **Bradley, Allen.** “Manual de Controles Eléctricos Industriales”. /s.c/, 1990. 150 pág.
- 📖 **Megyesy, Eugene F.** “Manual de Recipientes a Presión”. México, 1992. 482 pág.
- 📖 **Publicación de las Naciones Unidas.** “ Salvar la capa de Ozono: cada acción cuenta”. Francia, 48 pág.
- 📖 **Norma Venezolana, COVENIN 200:1999.** Código Eléctrico Nacional 6ª Revisión.

ANEXOS

APÉNDICE N° 1. OZONO.**A-1.1 Que es el Ozono.**

El ozono es una forma triatómica de oxígeno, es decir, su molécula tiene tres átomos, en vez de los dos del oxígeno común. El tercer átomo hace que esta sustancia sea venenosa y mortal, si se aspira una pequeña porción de la misma. Se forma naturalmente en las capas superiores de la atmósfera de la Tierra a partir de las radiaciones ultravioletas de alta energía del Sol. Por medio de procesos atmosféricos naturales, las moléculas de ozono se crean y se destruyen continuamente.

Cuando se absorbe energía de los rayos ultravioletas a las altas altitudes en la atmósfera, algunos enlaces moleculares de oxígeno (O_2) son rotos, dejando así átomos libres (Ec. 35). Estos átomos se recombinan con moléculas de oxígeno (Ec. 36), llevando a la formación de moléculas de ozono (O_3), el cual actúa como un filtro muy eficaz de rayos ultravioletas UV emitidos por el sol, impidiendo particularmente que los rayos de UVB (que son los más dañinos) alcancen la tierra.



donde

h = la constante de Planck,

ν = la frecuencia de radiación electromagnética,

$M = N_2, O_2$.

Las moléculas de ozono se disocian por la radiación solar (Ecuaciones 37 y 38) y por reacciones naturales con otras moléculas. La intensidad de formación del ozono, por consiguiente depende directamente de la intensidad de la radiación solar ($h\nu$). La concentración de ozono también varía como una función de la latitud y de la estación ya

que es transportado por circulación atmosférica a gran escala. De esta manera el ozono forma un escudo protector alrededor de la tierra.(ver figura N° 6)



Figura N° 6. Localización de la capa de ozono.

Un 90% de todo el ozono de la atmósfera se forma de esta manera, en una franja situada entre los 15 y 55 Km. arriba de la superficie de la Tierra.

A-1.2 Proceso de destrucción del ozono y el medio ambiente.

La capa de ozono estratosférico se redujo aproximadamente 1% entre 1976 y 1991 y entre 2% y 3% en la latitud norte durante los años de 1992 y 1993. Este resultado es basado en datos obtenidos del espectrómetro ultravioleta Dobson en el hemisferio norte. Esto ha sido confirmado en observaciones hechas por el instrumento TOMS (Espectrómetro del mapa total de ozono) a bordo del satélite Nimbus. Mientras que en el hemisferio sur, el agotamiento observado por el TOMS es más marcado y muestra una variación estacional más alta con la aparición de los agujeros en la capa de ozono sobre el Antártico en la primavera del sur. En esta región, un vórtice enorme se crea durante la larga noche polar en

la que las masas de aire están muy frías y permanecen relativamente aisladas de aquéllas en latitudes templadas. Cuando los primeros rayos solares llegan tempranamente en Septiembre, el ozono disminuye rápidamente, y al final de octubre este decaimiento puede alcanzar 50% a 60% dentro del vórtice. Este patrón se ha repetido prácticamente cada año desde 1980. en los años de 1985, 1987, 1989, 1991, y 1992 se observaron marcadamente valores mínimos de ozono que oscilaban entre 100 y 150 unidades *Dobson*¹ comparado con el nivel normal de 300 unidades en los años setenta.

La campaña de medida del NOZE (National Ozone Experiment) comenzada en 1986 por la NOAA (Administración Nacional Oceánica y Atmosférica) en la estación McMurdo de la Antártica hizo las primeras medidas de los constituyentes menores involucrados en la química del ozono en el vórtice polar. Este experimento reveló la desaparición casi completa del ozono en una capa relativamente delgada entre 14 y 27 Km. y la preponderancia de la química del cloro, que produce una concentración anormalmente alta del radical ClO^\cdot (óxido del cloro).

Para confirmar y aclarar el fenómeno de agotamiento, una segunda campaña que involucró el uso de aerotransportadores y equipo del satélite se llevó a cabo en 1987. Todos estos resultados mostraron claramente que la química de cloro es la causa principal de la destrucción del ozono. En particular, medidas de la concentración del radical ClO^\cdot fueron cien veces mayor que las medidas correspondientes a las latitudes medias.

Las condiciones meteorológicas extremas encontradas en el vórtice polar – temperaturas muy bajas cercanas de los -148°F (-100°C) y la presencia de nubes polares estratosféricas son todos factores que aumentan la eficacia de los ciclos de destrucción del ozono químico.

El cloro es considerado por consiguiente como el elemento esencial en la destrucción catalítica del ozono. Este se origina de las emisiones naturales y actividades humanas (antropogénica).

¹ Unidad Dobson: Si la atmósfera entera es considerada como una columna a una presión uniforme de 1 bar, el ozono ocuparía una capa de 3 mm de espesor; 100 Dobsons representan 1 mm de este espesor. El contenido "normal" es 300 Dobsons.

Se estima que las emisiones del cloro debido a la descomposición en la estratosfera de gases provenientes de fuentes naturales y de erupciones volcánicas resultan en un contenido de cloro de 0.6 partes por mil millones en 1950. Estas emisiones naturales son relativamente estables con el tiempo y contribuyen a mantener el equilibrio de la concentración del ozono. El contenido del cloro atmosférico en 1980 era de dos partes por mil millones y alcanza las tres partes por mil millones en 1988. Este aumento en el valor promedio del cloro en la estratosfera fue causado por la producción humana del cloro. Algunas de las sustancias involucradas son los clorofluorocarbonos o CFC's. El contenido de cloro aumenta conforme aumenta el contenido de atmosférico de CO₂ y metano.

El efecto invernadero es causado por radiación infrarroja de la tierra que es atrapada por ciertos gases atmosféricos. Este es un fenómeno natural sin el cual sería imposible la vida sobre la tierra ya que el clima estaría demasiado frío, con una Temperatura promedio de -0.4 °F(-180 °C) comparado con +59 °F; (+15°C), que son las condiciones actuales (Figura N° 7).



Figura N° 7. Distribución de energía solar.

Los componentes que causan el efecto invernadero son:

- Vapor de agua
- CO₂
- Otros gases llamados gases de "efecto invernadero".

Estos gases permiten que la radiación solar incidente pase absorbiendo radiación infrarroja de onda larga que regresa de la superficie de la tierra, impidiendo así que pueda escapar al espacio. Un incremento de la temperatura del aire también contribuye a aumentar el contenido de vapor de agua en la atmósfera, lo que crea un efecto invernadero mayor.

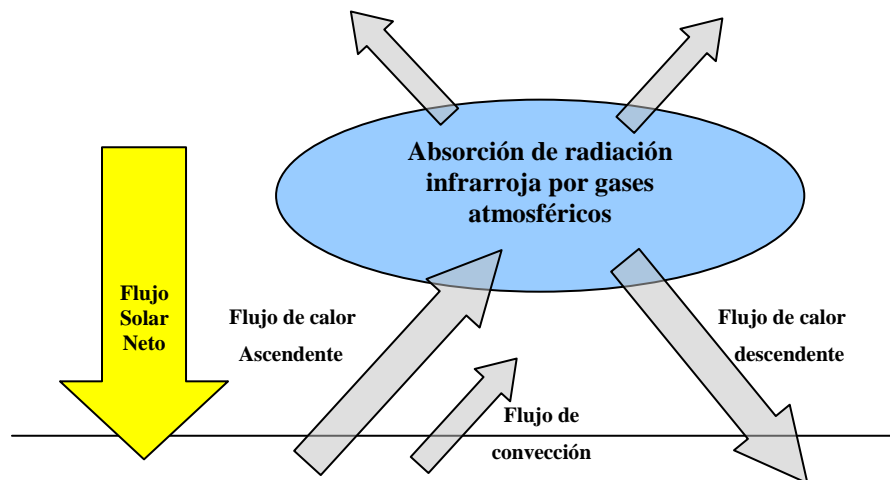
Las actividades humanas incrementan las concentraciones de estos gases, particularmente la combustión de combustibles fósiles para industria, calefacción, o transporte.

Aunque las proyecciones acerca del calentamiento atmosférico debido al CO₂ son sumamente variables en los diferentes modelos, todos predicen que doblando la concentración atmosférica de CO₂, aumentaría la temperatura promedio de la tierra entre 2.7 °F (1.5 °C) y 8.1 °F(4.5 °C), causando un gran número de inciertas consecuencias en los niveles del océano y la fauna, flora, recursos de agua, etc.

A-1.2.1 Influencia de los CFC's.

La estructura estable de los CFC's, les permite atacar la capa de ozono. Sin cambio alguno, flotan lentamente hasta la estratosfera, donde la intensa radiación ultravioleta rompe sus enlaces químicos. Así se libera el cloro, que captura un átomo de la molécula de ozono y lo convierte en oxígeno común. El cloro actúa como catalizador y provoca esta destrucción sin sufrir ningún cambio permanente él mismo, de modo que puede repetir el proceso. En estas condiciones, cada molécula de CFC destruye miles de moléculas de ozono. El CFC 11 dura en la atmósfera un promedio de setenta y cuatro años, el CFC 12 tiene una vida media de ciento once años, y el CFC 113 permanece durante unos noventa

años. Esto les da tiempo suficiente para ascender a la estratosfera y permanecer allí, destruyendo el ozono.

En la figura N° 8 se muestra el mecanismo de destrucción del ozono a causa del cloro en los gases refrigerantes halogenados.



Figura N° 8. Secuencia esquemática de la destrucción del ozono por el cloro activo liberado desde una molécula de CFC-12

La acción del cloro liberado por los CFC's es la principal teoría usada para explicar el rápido agotamiento de la capa de ozono

- Como los CFC's no son solubles en agua, contrario a la mayoría de los compuestos naturales de cloro, ellos no se enjuagan fuera de la troposfera.

- Las moléculas de CFC son sumamente estables y no descomponen en la atmósfera pero ascienden a la estratosfera.
- En la estratosfera, sus enlaces químicos son rotos debido a la acción de los rayos ultravioletas, liberando así átomos de cloro.
- Este cloro actúa como un catalizador para la destrucción de ozono transformando dos moléculas de ozono en tres moléculas de oxígenos.

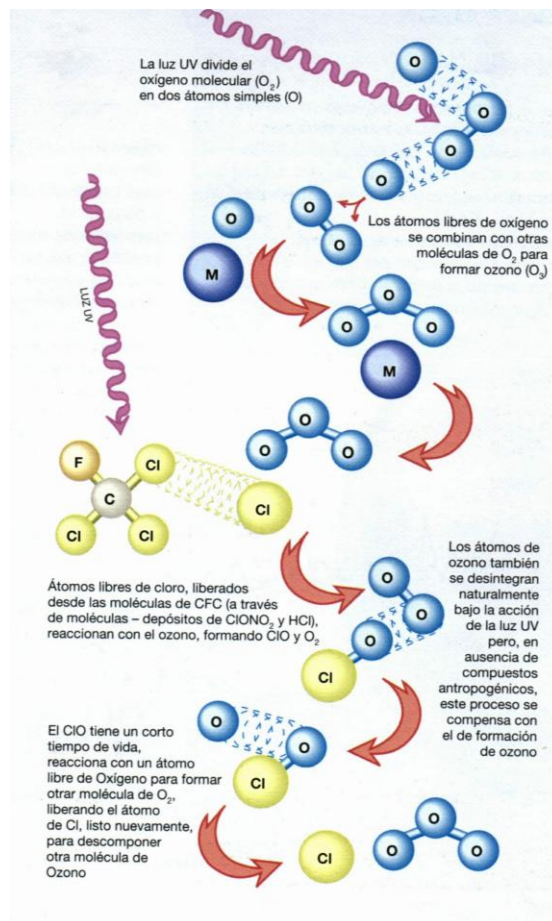
Para tener una medida del agotamiento del Ozono y del efecto invernadero que producen los refrigerantes se utilizan los siguientes parámetros:

- Potencial de Agotamiento del Ozono (ODP).
- Potencial de Calentamiento Global (GWP).

El ODP es un indicador de la reducción calculada del ozono bajo condiciones de estado estable por unidad de masa de gas emitida por año a una tasa uniforme en la atmósfera, comparado con una unidad de masa de CFC-11. Este es un coeficiente que expresa la acción sobre la capa de ozono de los productos que contienen cloro, incluso CFC's y HCFC's.²

Los valores del ODP, tomados del informe técnico del Programa Medioambiental de las Naciones Unidas en 1991 se muestran en la tabla siguiente:

² Productos de HCFC contienen hidrógeno que considerablemente reducen la vida del cloro en la atmósfera debido a las reacciones hidrolíticas. Cantidades de cloro agregadas a la estratosfera por estos productos son por consiguiente mucho más bajo que aquéllas agregados por productos de CFC.

TABLA N° 17. Valores de Ozono Depletion Potential (ODP).

<i>Refrigerante</i>	<i>Vida en la atmósfera (años)</i>	<i>ODP</i>
CFC-11	60	1
CFC-12	130	1
CFC-13	400	1
CFC-113	90	1,07
CFC-114	130	0,8
CFC-115	400	0,52
HCFC-22	15	0,055
HCFC-123	2	0,02
HCFC-124	7	0,022
HCFC-141b	18	0,11
HCFC-142B	19	0,065
HCFC-134a	--	0

Los ambientalistas prefieren refrigerantes que se caractericen por tener valores bajos de ODP y GWP y brinden buena eficiencia al sistema. Los refrigerantes que tienen átomos de Hidrógeno en sus moléculas tienen un tiempo de vida en la atmósfera relativamente corto en comparación con los que no tienen átomos de Hidrógeno; esto sucede porque una gran cantidad de estos refrigerantes se destruye en la baja atmósfera por reaccionar con los radicales OH, luego poseen valores bajos tanto de ODP como de GWP.

Los productos CFC tienen una muy alta capacidad de absorción de infrarrojo y son por lo tanto gases que contribuyen con el efecto invernadero. El índice GWP (potencial de calentamiento global) el cual mide la capacidad de atrapar energía radiante, caracteriza esta contribución con respecto al CO₂. El GWP puede ser definido como el efecto integrado de la contribución adicional de un kilogramo de este gas durante un tiempo dado comparado con la contribución de un kilogramo de CO₂.

Su valor es, por consiguiente, bastante variable dependiendo del tiempo de integración considerado, y esta duración siempre debe especificarse. Estos datos se reflejan en la tabla siguiente:

TABLA N° 18. Valores de Global Warming Potential (GWP).

<i>Gas</i>	<i>20 años</i>	<i>50 años</i>	<i>100 años</i>	<i>200 años</i>	<i>500 años</i>
CO₂	1	1	1	1	1
CFC-11	4500	4100	3400	2400	1400
CFC-12	7100	7400	7100	6200	4100
CFC-113	4600	4700	4500	3900	2500
CFC-114	6100	6700	7000	7000	5800
CFC-115	5500	6200	7000	7800	8500
HCFC-123	330	150	90	55	30
HCFC-134a	3100	1900	1200	730	400
CFC-113	4200	2600	1600	970	540

(Cuadro internacional del Cambio de Clima, 1992)

Otro factor que aumenta la complejidad de estimar la contribución de los CFC`s al efecto invernadero, es la contribución indirecta debido al consumo de energía de los sistemas refrigerantes. La mayoría de este consumo de energía es eléctrico para los sistemas de compresión de vapor. Esta contribución indirecta representa que el número de kilogramos de CO₂ expulsado a la atmósfera por la producción de cada kilovatio-hora eléctrico usado para producir enfriamiento.

Varios experimentos y cálculos han mostrado que la contribución indirecta de los sistemas termodinámicos al efecto invernadero es significativamente más alto que la contribución directa asociada con la expulsión de CFC`s.

Por ejemplo, para el refrigerador de una casa que usa CFC-12 y aislado con espuma de poliuretano que contiene CFC-11, la contribución indirecta (CO₂ expulsado por la

combustión en estaciones generadoras de potencia eléctrica³) representa el 80% de la contribución del sistema termodinámico al efecto invernadero, y CFC's expulsados a la atmósfera representan el restante 20%

Debe darse prioridad al diseño de nuevos sistemas termodinámicos y al mantenimiento o mejoramiento de su eficiencia energética para que el calentamiento global se minimice.

A-1.2.2 Efectos de la destrucción de la capa de Ozono.

Especialistas predicen que una pequeña reducción de este ozono estratosférico podría causar un aumento en el número de cánceres de piel (figura N° 9) y cataratas en los humanos; el debilitamiento y posible desaparición de algunas especies de granos, árboles, y animales; y un incremento de la tasa de degradación de algunos materiales (tales como plásticos). Cualquier cambio en la capa de ozono debido a causas naturales o causas antropogénicas (relacionadas a la actividad del hombre) tendrán por consiguiente, repercusiones en el clima y la vida de la superficie de la tierra.



Figura N° 9. Melanoma producido por los rayos ultravioleta.

³ Estos cálculos se llevaron a cabo para varias estaciones de potencia típicas en los Estados Unidos, incluyendo varias alimentadas por carbón y petróleo. En otros países donde la hidroelectricidad o la potencia nuclear dominan en la generación de electricidad, la contribución indirecta del CO₂ es por consiguiente más baja.

Otro efecto de los CFC es el calentamiento de la tierra, ya que estos contribuyen al efecto invernadero, y pueden causar el calentamiento de la Tierra. Teóricamente, una molécula de CFC11 ó 12 es más de 10.000 veces más efectiva que una molécula de bióxido de carbono, en su aporte al calentamiento del planeta. Sin embargo, se desconoce el efecto neto sobre el calentamiento de la Tierra de la emisión a la atmósfera de las sustancias dañinas para el ozono y la destrucción ulterior de la capa de ozono. En la figura N° 10 se muestra gráficamente el poder destructivo de las sustancias agotadoras de la capa de ozono que a su vez contribuyen con el efecto invernadero.



Figura N° 10. Relación entre los Potenciales de Agotamiento del Ozono y el Calentamiento Global

A-1.3 Principales acciones para la solución del problema.

En Septiembre de 1987 se firmó un acuerdo internacional llamado protocolo de Montreal, el cual contiene una lista de sustancias cuya producción y consumo deberá discontinuarse, así como también una lista de medidas de control para la fabricación, exportación e importación de productos químicos que deterioran la capa de ozono.

Lo ideal sería eliminar completamente el uso de estas sustancias en el mundo, sin embargo esto no es económicamente factible, sobre todo para los países en vías de desarrollo, por la gran cantidad de sistemas que manejan grandes cantidades de estos

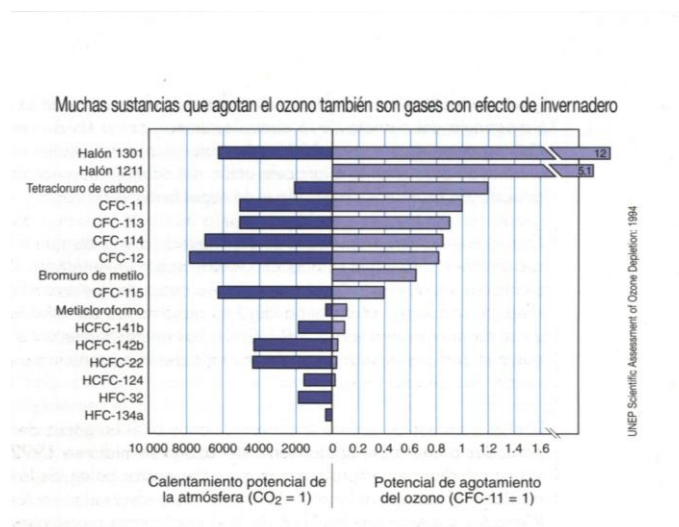
refrigerantes, lo que implicaría una gran inversión para convertir estos sistemas a otros que utilicen refrigerantes menos dañinos a la capa de ozono como lo son los Hidroclorofluorocarbonos (HCFC).

Por esto se han implementado políticas de reciclaje y regeneración de los CFC para no expulsarlos a la atmósfera. En este sentido, Venezuela en estos momentos es uno de los países pioneros en Latinoamérica en cuanto al desarrollo de programas de concientización de los entes involucrados en este problema, entiéndase técnicos en refrigeración, empresas de aire acondicionado y en general cualquier empresa o corporación que maneje este tipo de gases refrigerantes, en la implementación de políticas de recuperación, regeneración y reutilización de estos gases. Por esta razón es necesario, como primer paso, abastecer al territorio nacional de la tecnología necesaria para lograr este propósito.

APÉNDICE N° 2. CATÁLOGOS



Refrigeration & Air Conditioning System Protectors

Catalog RAC-1 USA
October 2000



Typical Heat Pump System

System protectors manufactured by Parker Hannifin highlighted in yellow.

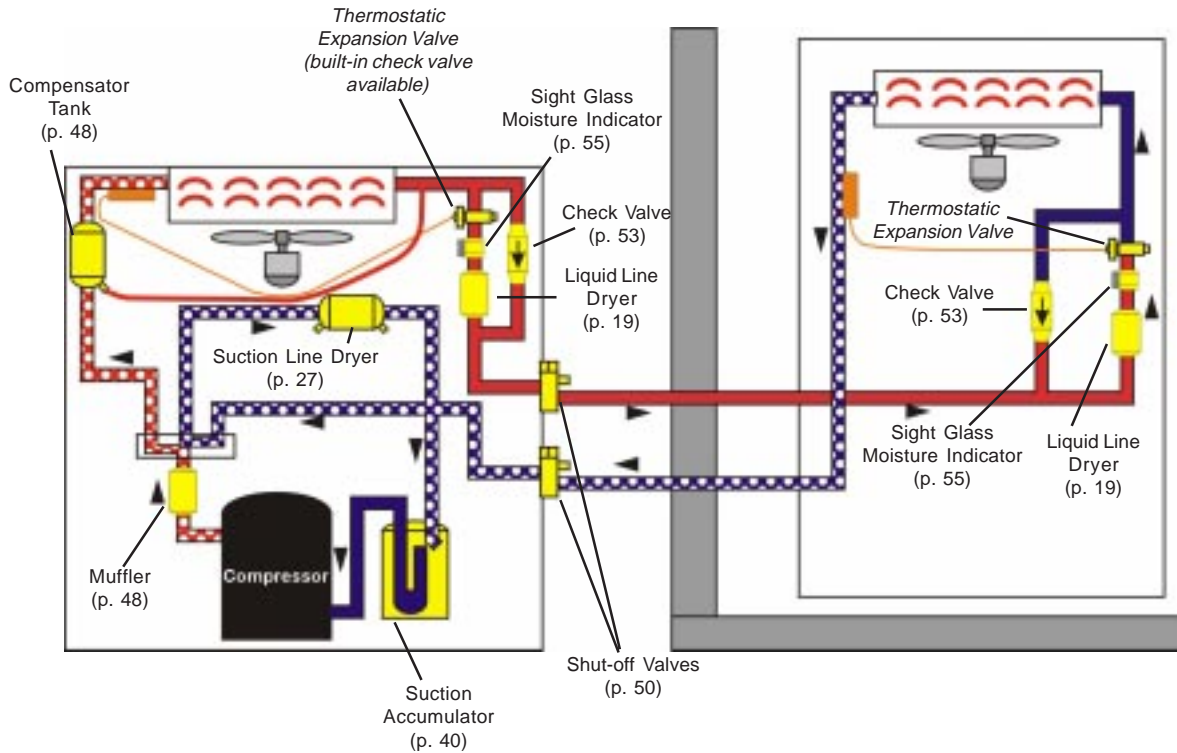

Be sure to contact Parker for all your other air-conditioning and refrigeration component needs, too, including:

- Thermostatic Expansion Valves
- Solenoid Valves
- Pressure Regulators
- Distributors and Flo-Raters



Typical Refrigeration System

System protectors and other components manufactured by Parker in green.

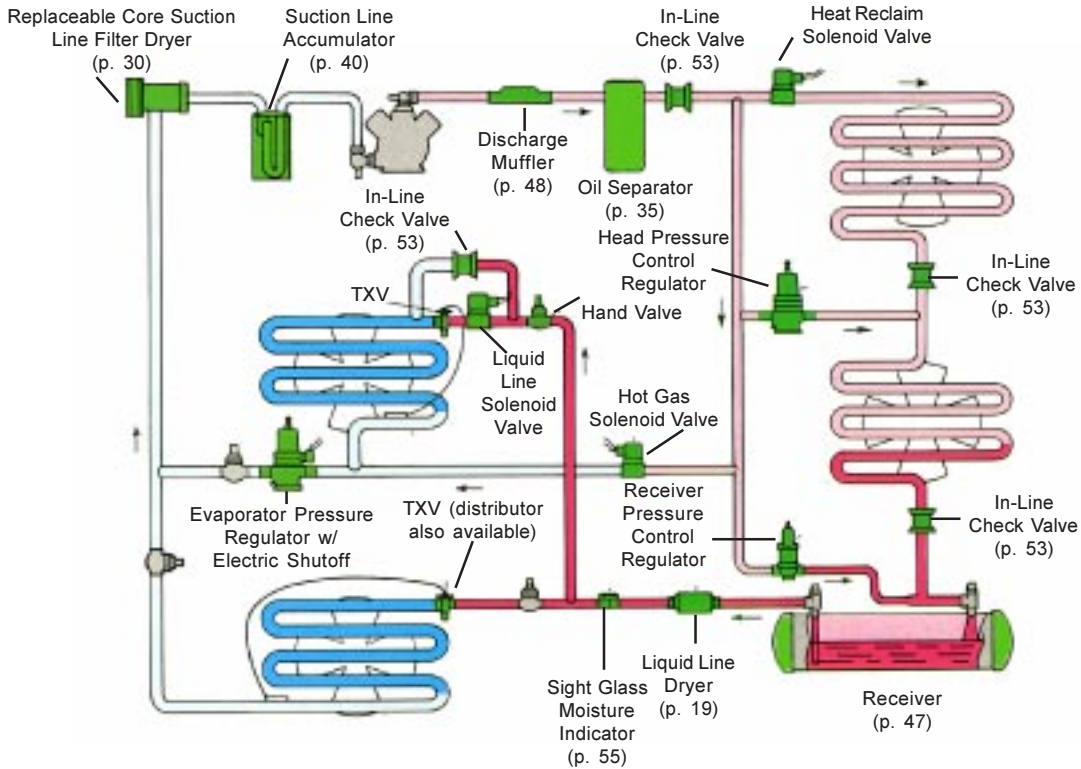

Also ask for Parker's inPHorm CD-ROM, the HVAC&R industry's first comprehensive software program for designing, selecting, and ordering refrigeration and air conditioning components. And be sure to visit our Web site at www.parker.com/cig



Introduction to System Protectors 5

Dryers/Filters 7

Dryers & R-410A 9

Spun Copper Dryers 12

Spring Loaded Copper Dryers 14

Copper Service Dryers 17

Steel Liquid Line Filter Dryers 19

Copper Liquid Line Solid Core Filter Dryers 23

Steel BiFlow Filter Dryers 25

Copper BiFlow Filter Dryers 26

Copper Suction Line Filter Dryers 27

Steel Suction Line Filter Dryers 27

Replacement Dryer Shells & Filter Cores 30

PreFilters, Oil Devices and Strainers 34

Accumulators 40

U-Tube Accumulators 42

Stand Pipe Accumulators 44

Copper Accumulators 44

Receivers 47

Compensator Tanks 48

Mufflers 48

Copper 48

Steel 49

Service Valves 50

Front Seated 50

Mini Split Valves 51

Brass Shut Off Valves 52

Check Valves 53

Copper 53

Brass 54

Sight Glasses and Moisture Indicators 55

Warning & Offer of Sale 60

Introduction to System Protectors

System protectors include those components that isolate, control, recognize or remove contaminants in a refrigeration or air conditioning system. Contaminants may include moisture, acid, noise, vibration, wax, tars, resins, large or micron-size particulate solids, glycol or brine solutions, and oils (mineral or POE). All close tolerance, moving parts in a system must be as free as possible of these contaminants to avoid extensive system damage.

Types of System Protectors

Parker Hannifin Corporation's Climate & Industrial Controls Group manufactures the refrigeration and air conditioning industries' most complete line of components for protecting refrigeration and air conditioning systems, including dryers, strainers/filters, accumulators, oil separators, heat exchanger accumulators, receivers, compensator tanks, mufflers, check valves, service valves, and sight glasses and moisture indicators.

Filter Dryers

Parker filter dryers are devices that protect systems by adsorbing and retaining moisture present in refrigerants and lubricating oils, in addition to filtering and collecting acids and solid particles. Selection of the proper dryer varies according to type of refrigerant, system tonnage, and other variables. Parker offers a variety of steel, bi-flow, liquid line, and suction line dryers, replaceable core shells, filter cores, and a full line of copper dryers.



Strainers & Pre-Filter Dryers

Strainers are low cost filtration devices designed to protect refrigeration components, including valves, compressors, and capillary tubes, from system contaminants. The size, type and cleanliness of a system and its components, as well as control of the assembly process, all determine the amount and size of the contaminants to be trapped by the strainer. For example, an extra large screen within the strainer should be selected if the strainer is expected to trap large amounts of foreign material. The large screen will insure there is enough area for passage of fluid without causing pressure drop. Parker strainers are copper with brass or stainless steel screens.



Parker prefilters and pre-filter dryers protect compressors and components by filtering refrigerant before it enters or circulates into the system.

Oil Separators

Parker offers two distinct types of oil separators. Vapor dryer separators are designed to remove contaminated oil from a system in addition to solids, acid and moisture. Parker's POS-321 oil separator removes oil from system refrigerant by means of a highly efficient coalescing filter.



Accumulators

An accumulator is an expansion chamber for liquid refrigerant that does not boil off in the evaporator coil. Accumulators are used extensively in low temperature refrigeration systems, heat pump applications, and some residential air conditioning systems. Parker offers standard accumulator models designed for application on heat pump and refrigeration systems from 1 1/2 through 12 tons. Parker accumulators are available in two design styles: a unique "U" tube design for maximum flow of refrigerant and minimum oil entrapment and stand pipe style for bottom outlet applications. In addition, copper accumulators are available in standard sizes from 1 1/8" to 2 1/4" and come with and without stand pipes with an orifice to meter liquid refrigerant and oil back to the compressor.



Receivers

Receivers are designed for refrigerant storage during normal system operation and system pump down, allowing the system to adjust to varying system conditions and loads. Parker receivers are available in steel and copper in various diameters with models designed for vertical or horizontal installations.



Compensator Tanks

Compensator tanks store excess refrigerant during the heating mode of the heat pump cycle, improving system efficiency during the defrost cycle. Various holding capacities are available.



Mufflers

A muffler is used to reduce compressor noise which is usually caused by the pressure pulses of the compressor and/or turbulent gas flow or vibration through the discharge line. Parker offers copper and steel mufflers.



Service Valves

Parker service valves are used to simplify isolation in liquid and suction lines and to provide positive shut off. Front-seated and back-seated designs are available for the greatest number of applications.



Check Valves

Parker check valves are copper or brass body devices used to prevent backflow in a system's liquid, suction or discharge lines. Parker check valves are available



with a special spring which allows mounting in most any position to insure shut-off. Ideal mounting location is in a vertical rise with flow in the up position.

**Sight Glass
Moisture Indicators**

The sight glass moisture indicator provides an easy way to quickly and accurately determine safe and/or hazardous moisture levels within a system. Parker sight glasses feature solid brass design, a universal indicator element and a leak-proof fused sight glass.



Introduction to Dryers

A dryer in a refrigeration system has two functions; one, to adsorb system contaminants such as water and acid, and two, to provide physical filtration.

Selecting a filter dryer for a particular application requires various technical factors to be considered. These factors include the type of system, connecting line size, water capacity, flow capacity (size of system), filtration capability, material of construction (steel versus copper), and safe working pressures. Evaluation of each factor is necessary to ensure proper and economical dryer design.

Parker Hannifin has developed filter dryer recommendations based on current technical data, as well as many years of actual field experience. They have been tested for flow and water capacity using the American Society of Heating, Refrigeration and Air Conditioning Engineers (ASHRAE) Standard 63.1 and are rated for use based on the Air Conditioning and Refrigeration Institute's guideline ARI 710. Data obtained from this testing is shown in the Capacities "(Ratings at ARI Standard Conditions)" tables for liquid line filter dryers and can be used as a comparison for filter dryers. However, other factors must be considered for various types of equipment.

Adsorbing Moisture and Preventing Acids

The ability to remove moisture from a refrigeration system is the most important function of a dryer. Moisture can come from many sources such as trapped air from improper evacuation, system leaks, and motor windings to name a few. Another source is due to improper handling of polyolester (POE) lubricants, which are hygroscopic; that is, they readily absorb moisture. POEs can pick up more moisture from its surroundings and hold it much tighter than the previously used mineral oils. This moisture can cause freeze-ups and corrosion of metallic components. Moisture in the system can also cause a reaction with POEs called hydrolysis, forming organic acids.

To prevent the formation of these acids, the moisture within the system must be minimized. This is accomplished by the use of desiccants within the filter dryer. The three most commonly used desiccants are molecular sieve, activated alumina and silica gel.

Molecular sieves are crystalline sodium aluminosilicates (synthetic zeolites) having cubic crystals,

which selectively adsorb molecules based on molecular size and polarity. The crystal structure is honeycombed with regularly spaced cavities or pores. Each of these cavities or pores are uniform in size. This uniformity eliminates the co-adsorption of molecules varying in size. This permits molecules, such as water, to be adsorbed, while allowing other larger molecules, such as the refrigerant, lubricant and acids, to pass by. The surface of this desiccant is charged positively with cations, which act as a magnet and will therefore adsorb polarized molecules, such as water, first and hold them tightly. The water molecules are physically separated from the lubricant, minimizing the potential for POE hydrolysis.

Activated alumina is formed from aluminum oxide (Al_2O_3) and is not a highly crystalline material. Both alumina and silica gel show a wide range of pore sizes and neither exhibit any selectivity based on molecular size. Due to the varying pore sizes, they can co-adsorb the much larger refrigerant, lubricant and acid molecules, eliminating the surface area available to adsorb water. Alumina can also aid in the hydrolysis of the POE lubricants creating organic acids since both water and lubricant are adsorbed into the pore openings of the alumina.

Silica gel is a non-crystalline material with a molecular structure formed by bundles of polymerized silica (SiO_2). Gel-type desiccants are indicative of the weaker bond formed between water and the desiccant. Silica gel is the old type of desiccant and is not widely used in today's filter dryers.

Selecting Desiccant Material

There are many factors involved when selecting which desiccant material is best for which application. Water capacity, refrigerant and lubricant compatibility, physical strength, and acid capacity are important characteristics of desiccants that should be considered.

Dryers are often placed on the liquid side of the system to remove moisture and some solids before the refrigerant travels through the expansion valve. Acid levels, both organic and inorganic, are not typically high on the liquid side, but some does exist and a dryer should be able to remove some of it. However, acid levels will remain low if the dryer can remove most of the moisture in the system. To accomplish this, the dryer must have an adequate water capacity level. Water capacity is the

amount of water or moisture the desiccant can hold while maintaining low levels within the refrigeration system.

FIGURE 1

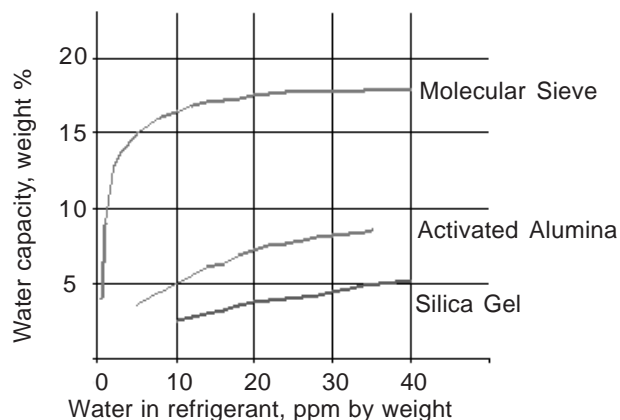

Figure 1 illustrates the water capacity of different desiccants as a percent of weight in an R-12 refrigerant system. It can be determined from this that the molecular sieve desiccant retains the highest amount of moisture. This type of isotherm represents unimolecular adsorption. This is due to the strong bond between the molecular sieve and water. The activated alumina desiccant retains a fair amount of moisture, as well. However, the retention isn't as great as the molecular sieve. This is indicative of co-adsorption of other materials and the weak hold activated alumina has on water.

In order to properly size a molecular sieve dryer, the maximum operating temperature should be known. The dryer should be located in the liquid line between the outlet of the condenser and the metering device. Typical water capacity is shown in drops of water per gram of molecular sieve, based on liquid line temperature, as shown in Table 1.

TABLE 1

Drops of Water							
R-12		R-22		R-502		R-134a	
75° F	125° F	75° F	125° F	75° F	125° F	75° F	125° F
3.72	3.52	3.40	3.24	3.40	3.24	3.40	3.20

Refrigerant and lubricant compatibility is essential when selecting the correct desiccant. Dryers are often used on the suction line side of a system to prevent foreign particles, acids, sludge and moisture from entering the compressor. Inorganic acid formation is predominantly found on the suction side and could cause corrosion and motor burnout. Inorganic acids (HCl and HF) form from the decomposition of the refrigerant. This may

happen as a result of added heat and moisture in the system. Inorganic acids formed will attack the crystal-line structure of the molecular sieve and break it down. Thus, it is important to keep the fluoride and chloride levels, found on the desiccant, low. Additionally, if the correct compatible desiccant is used, the measured levels of the F- and Cl- will remain low. Incompatible refrigerants and desiccants will promote decomposition and formation of these inorganic acids. Table 2 gives a summary of the compatible refrigerant and molecular sieve.

TABLE 2

Refrigerant	Desiccant
R-12	XH-6, XH-9, XH-11
R-22	XH-6, XH-9, XH-11
R-134a	XH-6, XH-9, XH-11
R-401A	XH-6, XH-9, XH-11
R-401B	XH-6, XH-9, XH-11
R-401C	XH-6, XH-9, XH-11
R-402A	XH-6, XH-9, XH-11
R-402B	XH-6, XH-9, XH-11
R-404A	XH-6, XH-9, XH-11
R-407A	*XH-6, XH-9*, XH-11
R-407B	*XH-6, XH-9*, XH-11
R-407C	*XH-6, XH-9*, XH-11
R-410A	*XH-6, XH-9*, XH-11
R-502	XH-6, XH-9, XH-11
R-507A	XH-6, XH-9, XH-11

* Note: Desiccant may adsorb R-32, causing the water capacity to be reduced. (Courtesy UOP)

Hydrolysis of the lubricant will form organic acids. Organic acids are the carboxylic acids that are the result of POE lubricants reacting with water in the system. The water attacks the POE lubricant and breaks it down into its original components (carboxylic acid and alcohol). This breakdown of the POE lubricant will not happen if minimal moisture is present in the system. The levels of these acids can be reduced by keeping the moisture level in the system low. Table 3 reveals the acid capacity of two types of desiccants.

TABLE 3

Desiccant	Inorganic Acid Capacity (% by wt)	Organic Acid Capacity (% by wt)
Molecular Sieve	approx 6%	0.80%
Activated Alumina	approx 6%	5.50%

The formation of these organic and inorganic acids will cause the water capacity of the desiccant to decrease. Therefore, it is important to know the compatibility of

the components within a refrigerant system. *Table 4* displays the various refrigerants and the compatible lubricant.

TABLE 4

Refrigerant	Lubricant
R-12	Alkylbenzene and Mineral Oil
R-22	Alkylbenzene and Mineral Oil
R-134a	POE (Polyolester)
R-401A	Alkylbenzene/POE (Polyolester)
R-401B	Alkylbenzene/POE (Polyolester)
R-401C	POE (Polyolester)
R-402A	Alkylbenzene/POE (Polyolester)
R-402B	Alkylbenzene/POE (Polyolester)
R-404A	POE (Polyolester)
R-407A	POE (Polyolester)
R-407B	POE (Polyolester)
R-407C	POE (Polyolester)
R-410A	POE (Polyolester)
R-502	POE (Polyolester)
R-507A	POE (Polyolester)

Courtesy Allied Signal

Desiccants should be strong enough mechanically to resist breaking up when subjected to system vibrations and surges. Incompatible combinations of refrigerant, lubricant and desiccant will have low crush strength and high attrition values. Crush strength can be defined as the force required to break the individual beads of desiccant. Attrition occurs when the desiccant is shaken or vibrated to yield fine particles.

Guidelines for Parker Dryers and R-410A

Liquid line dryers are used in refrigeration systems to insure removal of contaminants and protect systems. The new refrigerant and lubricant combinations that have come in the wake of the regulation of CFCs and HCFCs have brought many changes to liquid line filter dryers. In particular, the introduction of Refrigerant 410A and Polyol Ester (POE lubricants) for the phase out of R-22 and mineral oil has created many design challenges as far as water and solid contaminant removal, refrigerant and lubricant compatibility and increased working pressures of the systems.

The basic job of a liquid line filter dryer is to remove water and solid contaminants from a refrigeration system. Water can get into systems from various sources. Some of these are leaks, improper cleaning and evacuation, polyolester (POE) lubricants and

Steel vs. Copper

The major differences in using steel versus copper dryers are the system sizes and applications. Copper dryers are normally used in smaller systems, systems with less pressure fluctuations and lower vibration tendencies. Some smaller systems do not require high filtration capabilities; however, some of the smaller systems using the new refrigerants will require better filtration. In order to meet these requirements a core dryer and dryers with additional filter media, besides a screen, should be used. Also, copper is typically the most economical option for smaller systems. Because copper dryers are used for smaller applications, the refrigerant charge required will generally be smaller than in the steel dryer. In order to determine how much desiccant is required to properly remove the moisture in a system, information regarding the total amount of refrigerant charge is required. When used in conjunction with system horsepower, maximum operating temperature and maximum operating pressure, the total system moisture can be calculated. The total system moisture information is used to determine adequate dryer capacity.

Information regarding operating pressure is required to adequately size the wall thickness of the dryer to attain the ultimate burst pressure, for both copper and steel. In accordance with Underwriters Laboratories (UL) and the Canadian Standards Association (CSA), the burst pressure is rated as five times the design working pressure of the system, or as three times the design working pressure of the system along with a fatigue stress test, as per UL 1995. Typically, for copper dryers, the design working pressure value can be correlated to tube diameter and wall thickness in order to meet specific UL specifications.

windings in electric motors. This water has to be removed to prevent freeze-ups, corrosion, and possible hydrolysis of the ester lubricant. Solid contaminants, like copper oxide, carbon, braze particles, etc., can clog metering devices or cause problems in the compressor. They are removed by filter media such as fiberglass pads, screens, and cores.

The new refrigerants and lubricants are excellent solvents. As a result, contaminants that R-22 and mineral oil left in place are now removed by HFC refrigerants such as R-410A/R-407C and POEs. Some of these common contaminants are residual detergents from cleaning, drawing compounds, rust preventatives, plasticizers and lubricant additives. These contaminants can deposit in capillary tubes, restrictor orifices or txv seats.

Polyolester lubricants are made by reacting organic acids with alcohols to form the ester chains that make up the lubricant and water. This reaction is reversible, so under the right conditions, the lubricant can react with excess water to reverse the ester reaction and decompose into the original organic acid and alcohol. The organic acid can then deposit in the expansion device, restricting the flow. This was not an issue with the earlier HFC/CFC/mineral oil systems chemistry. In addition, polyolesters are hygroscopic so they can absorb a large amount of water. Studies have shown that activated alumina in the liquid line can play a role in the hydrolysis of the polyolester.

Refrigerant blends that have R-32 (a component of R-410A and R-407C) pose another issue for dryer manufacturers. R-32 is very close to water in terms of molecular size. This means that some desiccants can adsorb R-32 which lowers the water capacity of the desiccant. The more immediate effect is that the composition of the blend can change if there is enough R-32 adsorbed.

The Parker Solution

All of these factors have required changes in the internal components of liquid line dryers. From the outside, they remain the same but internally changes have been made to accommodate the new refrigerants and lubricants.

Filtration capacity in Parker liquid line dryers has been designed to insure that the dryer is able to handle the higher levels of contaminants. The filtration capacity of a Parker liquid line dryer and a comparably sized core liquid line dryer is shown in *Figure 1*. When

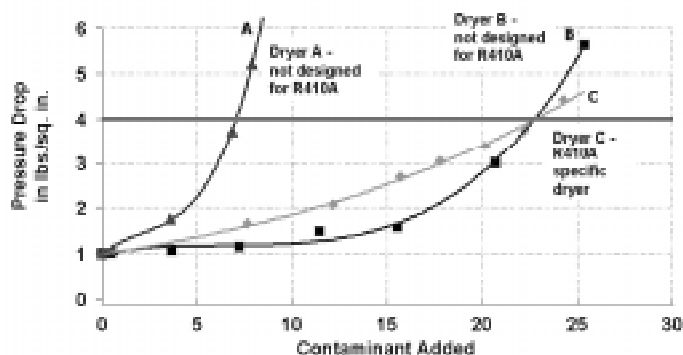

FIGURE 1 - R410A Steel Liquid Line Dryer Filtration. (Note: 4 PSID is the baseline Parker uses when determining filtration capacity.)

tested per ASHRAE 63.1, allowing a maximum pressure drop of four psi, the core dryer reaches that level with the addition of seven grams of contaminant, while the Parker dryer holds 23 grams before reaching the same pressure drop. At the same time, filtration capability, the ability to remove small particles, has not

been compromised. In the same test, Parker dryers have filtration efficiencies up to 95%, which is a requirement for R-410A dryers.

The same filtration performance has been designed into bi-directional dryers for heat pumps. *Figure 2* shows the results of testing of a standard bi-directional dryer

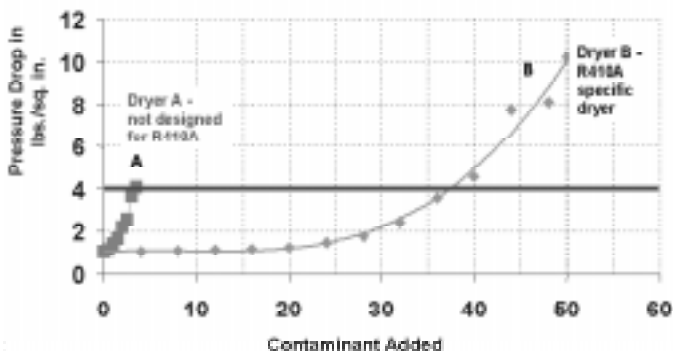

FIGURE 2 - R410A Heat Pump Dryer Filtration. (Note: 4 PSID is the baseline Parker uses when determining filtration capacity.)

and the Parker R-410A bi-directional dryer. The standard dryer holds 4 grams of contaminant while the R-410A specific dryer holds 36 grams of contaminant before reaching 4 psi pressure drop.

The desiccant (drying agent) used in the dryer had to be developed to be able to adsorb water and exclude R-32. This new desiccant is UOP's XH11. This is the desiccant that is used exclusively in Parker's R-410A liquid line dryers. The pore openings are specifically designed to adsorb moisture while excluding the R-32, lubricant and additives. This insures maximum water capacity in the dryer and allows the water to be physically separated from the POE lubricant to prevent hydrolysis. Activated alumina on the other hand has pore openings that will adsorb not only the water but the R-32, POE lubricant and it's additives, which lowers it's drying capabilities and removes essential additive's from the lubricant. It also gives the water and the lubricant a surface for the hydrolysis reaction since they can co-exist in the alumina's openings. The water is not physically separated from the lubricant.

Figure 3 displays the water capacity of different desiccants in R-22. It can be seen from this graph that molecular sieve 4A-XH-6 has approximately 3-4 times higher water capacity than acitvated alumina and silica gel.

Figure 4 shows the water capacity for different molecular sieve desiccants in R-410A. The steepness of the XH11 curve at low levels of water shows its high water capacity at low water levels. This means that it takes

less XH11 than other sieve desiccants to dry refrigerants to low levels of water.

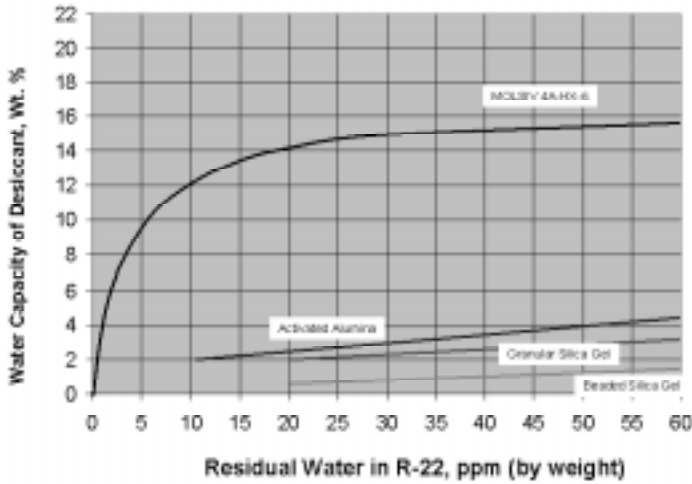

FIGURE 3 - Water capacity of different desiccants in R-22 at 140° F. (Note: MOLSIV 4A-HX-6 is a trade name of UOP.)

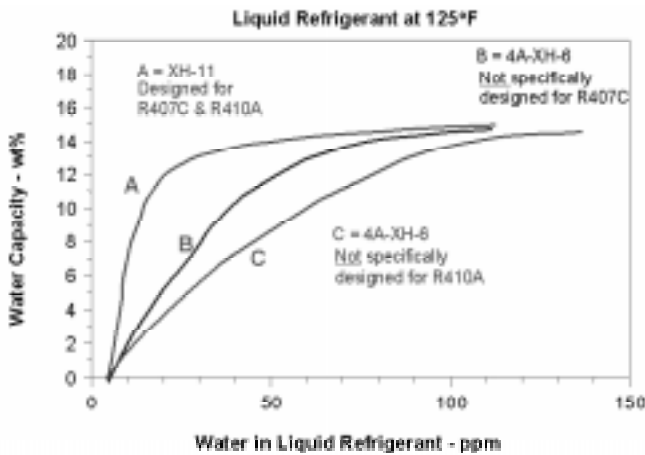

FIGURE 4 - Water capacity of different desiccants in R-410A at 125° F. (Note: XH-11 and HX-6 are trade names of UOP.)

Standard Products for R-410A

- 100% molecular sieve XH11 desiccant.
- Ensures no degradation of the R-32 within the make-up of R410A.
- Parker has worked with the industry in establishing a pink colored label on all products for use with R410A. Competitive products without pink labels should not be used and may cause system damage.
- See main liquid line and biflow dryer sections in this catalog for dimensional data.
- Other sizes of R-410A specific dryers are available. Consult Parker.

Figure 5 displays the reaction of molecular sieve and activated alumina with a POE lubricant and HFC refrigerant. After exposure of the desiccants to the POE and HFC refrigerant in a sealed glass tube for 14 days and 180F, the activated alumina showed organic acid levels almost 40 times higher than that of molecular sieve. This is an indication of the breakdown of the lubricant. The fluoride levels were low indicating compatibility with the refrigerant.

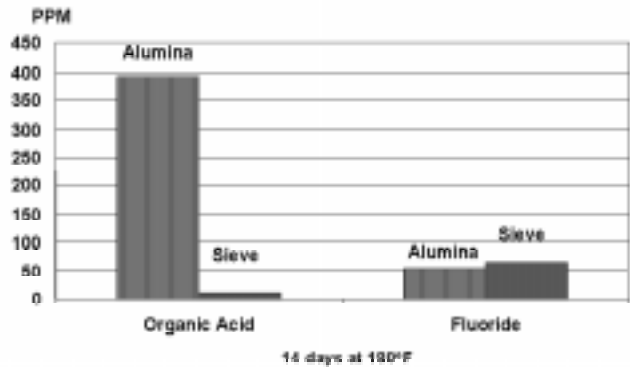

FIGURE 5 - Sealed tube test results.

Parker liquid line dryers have been designed specifically to meet the demands of the new HFC refrigerants. R-410A in particular, due to its higher pressures, required stronger construction to meet these working pressures. Parker liquid line dryers are UL listed for use with R-410A. This, in addition to increased filtration capacities, water capacity and compatibility insure that Parker liquid line dryers will provide R-410A systems maximum protection which leads to long reliable operation.

Model	ARI Flow Capacity @ 1 PSI	Recommended A/C Nominal Tons	Water Drop Capacity in R410A (50 ppm) 75F/125F
Liquid Line Dryers			
053S-410A	4.64	4	86/77
083S-410A	4.92	5	131/117
163S-410A	5.75	5	254/226
303S-410A	6.03	6	446/397
Bi-flow Dryers			
BF163S-XF	3.5	5	197/176

Spun Copper Dryers

Key Features & Benefits

- 100% molecular sieve beads for max water capacity.
- Spun copper shells and ends for easy solder installation.
- Brass or stainless steel screen material for corrosion resistance and maximum contaminant removal.
- Perforated baffle support plate ensures rigid containment of molecular sieve.
- UL recognized components. File #SA8570 CSA LR87950
- Available in a variety of inlet and outlet sizes.
- One and two inlets are available as well as cap tube sizes on outlet from .081 to .125



3/4" O.D. Copper Dryer

Part No.	Design Working Pressure PSI	Inlet Inches	Outlet Inches	Overall Length Inches
032099-00	360	.164 .159/ .258 253	.091 .086	4.63
032159-00	360	.164 .159	.091 .086	4.50
032200-00	500	.195 .190	.081 .076	4.37
032169-00	360	.197 .192	.092 .087	4.75

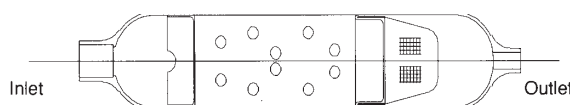

Recommended tonnages: 1/4 to 1/2 tons depending on application and system. Consult Parker.

3/4" O.D. Copper Dryer Water Capacities

Part No.	Water Capacity in drops of water													
	R-12		R-22		R-134a		R-401A / B		R-401C		R-402A		R-402B	
	75°	125°	75°	125°	75°	125°	75°	125°	75°	125°	75°	125°	75°	125°
032099-00	33.0	30.6	29.8	27.4	32.6	31.0	32.6	30.2	30.6	28.8	33.2	30.6	33.0	30.6
032159-00	33.0	30.6	29.8	27.4	32.6	31.0	32.6	30.2	30.6	28.8	33.2	30.6	33.0	30.6
032200-00	28.1	26.0	25.3	23.3	27.7	26.4	27.7	25.7	26.0	24.5	28.2	26.0	28.1	26.0
032169-00	33.0	30.6	29.8	27.4	32.6	31.0	32.6	30.2	30.6	28.8	33.2	30.6	33.0	30.6

Part No.	Water Capacity in drops of water													
	R-404A		R-407A		R-407B		R-407C		R-410A		R-502		R-507A	
	75°	125°	75°	125°	75°	125°	75°	125°	75°	125°	75°	125°	75°	125°
032099-00	32.8	30.6	24.2	22.2	24.2	22.2	26.2	23.6	19.8	17.4	30.4	28.6	32.8	30.8
032159-00	32.8	30.6	24.2	22.2	24.2	22.2	26.2	23.6	19.8	17.4	30.4	28.6	32.8	30.8
032200-00	27.9	26.0	20.6	18.9	20.6	18.9	22.3	20.1	16.8	14.8	25.8	24.3	27.9	26.2
032169-00	32.8	30.6	24.2	22.2	24.2	22.2	26.2	23.6	19.8	17.4	30.4	28.6	32.8	30.8

One and two inlets are available as well as cap tube sizes on outlet from .081 to .125.

1" O.D. Copper Dryer

Part No.	Design Working Pressure PSI	Inlet Inches	Outlet Inches	Overall Length Inches
032083-00	500	.250 .244	.098 .093	4.00
058066-00	500	.380 .377/ .256 .253	.195 .190	4.19
057404-00	500	.320 .315	.320 .315	3.81

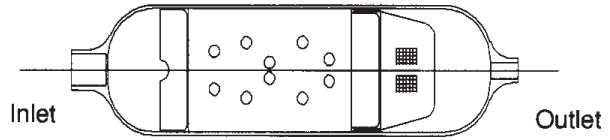

Recommended tonnages (part numbers 032083-00 and 058066-00):
 1/4 to 1/2 tons depending on application and system. Consult Parker.

Recommended tonnages (part 057404-00): R-12 = 1/2; R-22 = 2; R-134a = 2; R-401A = 2; R-404A = 1.3; R-410A = 2; R-502 = 1.3; and R-507A = 1.3.

1" O.D. Copper Dryer Water Capacities

Part No.	Water Capacity in drops of water													
	R-12		R-22		R-134a		R-401A / B		R-401C		R-402A		R-402B	
	75°	125°	75°	125°	75°	125°	75°	125°	75°	125°	75°	125°	75°	125°
032083-00	43.0	39.4	N/R	N/R	40.32	37.68	N/R	N/R	N/R	N/R	N/R	N/R	N/R	N/R
058066-00	49.5	45.9	44.7	41.1	48.9	46.5	48.9	45.3	45.9	43.2	49.8	45.9	49.5	45.6
057404-00	60.5	58.6	54.7	50.6	59.8	57.0	58.6	53.1	57.0	52.5	59.4	53.8	59.4	53.8

Part No.	Water Capacity in drops of water													
	R-404A		R-407A		R-407B		R-407C		R-410A		R-502		R-507A	
	75°	125°	75°	125°	75°	125°	75°	125°	75°	125°	75°	125°	75°	125°
032083-00	N/R	N/R	N/R	N/R	N/R	N/R	N/R	N/R	N/R	N/R	N/R	N/R	N/R	N/R
058066-00	49.2	45.9	36.3	33.3	36.3	33.3	39.3	35.4	29.7	26.1	45.6	42.9	49.2	46.2
057404-00	59.5	56.0	39.4	35.6	39.4	35.6	41.9	37.8	32.3	28.8	55.7	52.5	60.2	56.3

NR = not recommended. Consult Parker for more information.

Spring Loaded Copper Dryers

Spring loaded dryers are used in air conditioning and refrigeration units that exceed 1 horsepower. The design of spring loaded dryers incorporates a spring and spring retainer to compact the load of the molecular sieve. The spring stops attrition by preventing the sieve from moving.

1" O.D. Spring Loaded Copper Dryer Data

Part No.	Design Working Pressure PSIG	Inlet Inches	Outlet Inches	Overall Length Inches
032231-00	500	.202 .192 .381 .378	.133 .128	4.25
054625-01	500	.256 .253	.256 .253	4.38
056242-03	500	.383 .378	.383 .378	4.38
053817-01	500	.378 .383	.378 .383	5.69

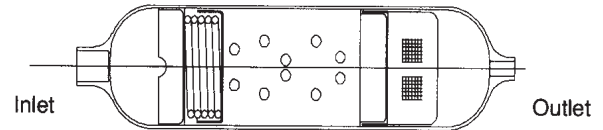

Part No.	Maximum flow rate at 1 psig in tons														
	R-12	R-22	R-134A	R-401A	R-401B	R-401C	R-402A	R-402B	R-404A	R-407A	R-407B	R-407C	R-410A	R-502	R-507A
032231-00	Recommended Tonnages: 1/2 to 1 tons depending on application and system. Consult Parker.														
054625-01	1.5	1.5	1.6	1.8	1.5	1.4	1.0	1.2	1.2	1.3	1.1	1.4	1.7	1.2	1.2
056242-03	2.7	3.6	3.3	3.6	3.7	3.3	2.4	2.8	2.4	3.1	2.5	3.5	3.5	2.3	2.3
053817-01	2.3	3.0	2.7	3.0	3.1	2.7	2.0	2.4	2.0	2.6	2.1	2.9	2.9	1.9	2.0

1" O.D. Spring Loaded Copper Dryer Water Capacities

Part No.	Water Capacity in drops of water													
	R-12		R-22		R-134a		R-401A / B		R-401C		R-402A		R-402B	
	75°	125°	75°	125°	75°	125°	75°	125°	75°	125°	75°	125°	75°	125°
032231-00	33.0	30.6	29.8	27.4	32.6	31.0	32.6	30.2	32.8	30.8	33.2	30.6	33.2	30.6
054625-01	51.0	49.4	46.2	42.7	50.5	48.1	49.4	44.8	49.4	44.8	49.4	44.8	49.4	44.8
056242-03	51.0	49.4	46.2	42.7	50.5	48.1	49.4	44.8	49.4	44.8	49.4	44.8	49.4	44.8
053817-01	94.5	91.5	85.5	79.0	93.5	89.0	91.5	83.0	91.5	83.0	91.5	83.0	91.5	83.0

Part No.	Water Capacity in drops of water													
	R-404A		R-407A		R-407B		R-407C		R-410A		R-502		R-507A	
	75°	125°	75°	125°	75°	125°	75°	125°	75°	125°	75°	125°	75°	125°
032231-00	32.8	30.6	24.2	22.2	24.2	22.2	26.2	23.6	19.8	17.4	30.4	28.6	32.8	30.8
054625-01	50.2	47.3	49.4	44.8	49.4	44.8	49.4	44.8	27.3	24.3	47.0	44.3	50.8	47.5
056242-03	50.2	47.3	49.4	44.8	49.4	44.8	49.4	44.8	27.3	24.3	47.0	44.3	50.8	47.5
053817-01	93.0	87.5	91.5	83.0	91.5	83.0	91.5	83.0	50.5	45.0	87.0	82.0	94.0	88.0

One and two inlets are available as well as cap tube sizes on outlet from .125 to .50. All 1" dryers are U.L. recognized components, File #SA8570. Tonnage ratings will vary depending on the inlet and outlet requested.

1- 3/16" O.D. Spring Loaded Copper Dryer Data

Part No.	Design Working Pressure PSI	Inlet Inches	Outlet Inches	Overall Length Inches
056243-04	500.0	.508 .503	.508 .503	5.1
056243-03	500.0	.383 .378	.383 .378	5.1
053776-00	540.0	.384 .378	.384 .378	7.0

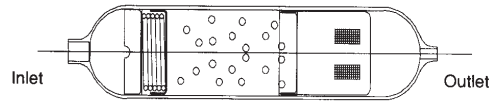

Part No.	Maximum flow rate at 1 psig in tons														
	R-12	R-22	R-134a	R-401A	R-401B	R-401C	R-402A	R-402B	R-404A	R-407A	R-407B	R-407C	R-410A	R-502	R-507A
056243-04	3.6	4.8	4.4	4.7	5.0	4.4	3.2	3.8	3.1	4.2	3.4	4.6	4.7	3.1	3.1
056243-03	2.7	3.6	3.3	3.5	3.7	3.3	2.4	2.8	2.3	3.1	2.5	3.5	3.5	2.3	2.3
053776-00	2.8	3.7	3.4	3.7	3.8	3.4	2.5	2.9	2.4	3.2	2.6	3.6	3.6	2.4	2.4

1- 3/16" O.D. Spring Loaded Copper Dryer Water Capacities

Part No.	Water Capacity in drops of water													
	R-12		R-22		R-134a		R-401A / B		R-401C		R-402A		R-402B	
	75°	125°	75°	125°	75°	125°	75°	125°	75°	125°	75°	125°	75°	125°
056243-04	94.5	91.5	85.5	79.0	93.5	89.0	91.5	83.0	89.0	82.0	92.8	84.0	92.8	84.0
056243-03	94.5	91.5	85.5	79.0	93.5	89.0	91.5	83.0	89.0	82.0	92.8	84.0	92.8	84.0
053776-00	170.1	164.7	153.9	142.2	168.3	160.2	164.7	149.4	160.2	147.6	167.0	151.2	167.0	151.2

Part No.	Water Capacity in drops of water													
	R-404A		R-407A		R-407B		R-407C		R-410A		R-502		R-507A	
	75°	125°	75°	125°	75°	125°	75°	125°	75°	125°	75°	125°	75°	125°
056243-04	93.0	87.5	61.5	55.6	61.5	55.6	65.5	59.0	50.5	45.0	87.0	82.0	94.0	88.0
056243-03	93.0	87.5	61.5	55.6	61.5	55.6	65.5	59.0	50.5	45.0	87.0	82.0	94.0	88.0
053776-00	167.4	157.5	110.7	100.0	110.7	100.0	117.9	106.2	90.9	81.0	156.6	147.6	169.2	158.4

One and two inlets are available as well as cap tube sizes on outlet from .25 to .50. All 1 3/16" dryers are UL recognized components, File #SA8570. Tonnage ratings will vary depending on the inlet and outlet requested.

1- 5/8" Spring Loaded Copper Dryer

Part No.	Design Working Pressure PSI	Inlet Inches	Outlet Inches	Overall Length Inches
032040-00	500	.383 .378	.383 .378	6.00
032145-00	500	.383 .378	.383 .378	4.38
031805-03	500	.383 .378	.383 .378	5.50
056244-01	500	.383 .378	.383 .378	5.38
056156-01	500	.253 .256	.253 .256	7.00

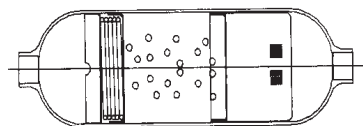

Part No.	Maximum flow rate at 1 psig in tons														
	R-12	R-22	R134A	R-401A	R-401B	R-401C	R-402A	R-402B	R-404A	R-407A	R-407B	R-407C	R-410A	R-502	R-507A
032040-00	4.4	5.8	5.3	5.8	6.0	5.3	3.9	4.6	3.8	5.1	4.1	5.6	5.7	3.8	3.8
032145-00	3.5	4.7	4.3	4.6	4.8	4.3	3.2	3.7	3.1	4.1	3.3	4.5	4.6	3.0	3.1
031805-03	3.8	5.1	4.7	5.0	5.3	4.6	3.4	4.0	3.3	4.5	3.6	4.9	5.0	3.3	3.3
056244-01	3.7	5.0	4.5	4.9	5.2	4.6	3.4	3.9	3.2	4.4	3.5	4.8	4.8	3.2	3.2
056156-01	1.3	1.8	1.6	1.8	1.9	1.6	1.2	1.4	1.2	1.6	1.3	1.7	1.7	1.2	1.2

1- 5/8" O.D. Spring Loaded Copper Dryer Water Capacities

Part No.	Water Capacity in drops of water													
	R-12		R-22		R-134a		R-401A / B		R-401C		R-402A		R-402B	
	75°	125°	75°	125°	75°	125°	75°	125°	75°	125°	75°	125°	75°	125°
032040-00	170.1	164.7	153.9	142.2	168.3	160.2	164.7	149.4	160.2	147.6	167.0	151.2	167.0	151.2
032145-00	92.4	85.7	83.4	76.7	91.3	86.8	91.3	84.6	85.7	80.6	93.0	85.7	92.4	85.7
031805-03	132.3	128.1	119.7	110.6	130.9	124.6	128.1	116.2	124.6	114.8	129.9	117.6	129.9	117.6
056244-01	170.1	164.7	153.9	142.2	168.3	160.2	164.7	149.4	160.2	147.6	167.0	151.2	167.0	151.2
056156-01	340.2	329.4	307.8	284.4	336.6	320.4	329.4	298.8	320.4	295.2	333.9	302.4	333.9	302.4

Part No.	Water Capacity in drops of water													
	R-404A		R-407A		R-407B		R-407C		R-410A		R-502		R-507A	
	75°	125°	75°	125°	75°	125°	75°	125°	75°	125°	75°	125°	75°	125°
032040-00	167.4	157.5	110.7	100.0	110.7	100.0	117.9	106.2	90.9	81.0	156.6	147.6	169.2	158.4
032145-00	91.8	85.7	67.8	62.2	67.8	62.2	73.4	66.1	55.4	48.7	85.1	80.1	91.8	86.2
031805-03	130.2	122.5	86.1	77.8	86.1	77.8	91.7	82.6	70.7	63.0	121.8	114.8	131.6	123.2
056244-01	167.4	157.5	110.7	100.0	110.7	100.0	117.9	106.2	90.9	81.0	156.6	147.6	169.2	158.4
056156-01	334.8	315.0	221.4	200.0	221.4	200.0	235.8	212.4	181.8	162.0	313.2	295.2	338.4	316.8

One and two inlets are available as well as cap tube sizes on outlet from .125 to 5/8. All 1 5/8" dryers are UL recognized components, File #SA8570. Tonnage ratings will vary depending on the inlet and outlet requested.

Service Dryers

Key Features and Benefits

- 100% XH-9 molecular sieve is specially formulated for the new refrigerants and blends, including 134a, 404A, and 507A.
- Compatible with mineral oils and the new synthetics (POEs).
- All copper construction for corrosion resistance.
- Worldwide OEM usage and acceptance.
- UL recognized and CSA certified.



MMS-80/100



MMS-200



712



319



620



CO73S

Copper Service Dryer Specifications

MRO Model No.	Part No.	Molecular Sieve	Description	Overall Length	Inlet Tube Size OD / ID	Outlet Tube Size OD / ID
MMS-80	058070-01	10g XH9	3/4" Non-directional	7 3/8"	1/4" / 3/16"	1/4" / 3/16"
MMS-100	058198-01	10g XH9	3/4" directional	7 3/8"	1/4" / 3/16"	1/4" / 3/16"
MMS-200	032134-01	20g XH9	1" directional step down	10 1/2"	1/4" / 3/16" 5/16" / 1/4" 3/8" / 5/16"	1/4" / 3/16" 5/16" / 1/4" 3/8" / 5/16"
712	032092-00	10g XH9	3/4" directional	8 1/2"	1/4" / 3/16"	.089 / .092 cap. tube
319	032144-00	30g XH9	1 3/16" directional	9 3/4"	5/16" OD	.127 / .130
619	032142-00	10g XH9	3/4" w/ access valve	8 7/8"	1/4" / 3/16"	.089 / .092 cap. tube
620	032133-00	20g XH9	1" w/ access valve	9 1/2"	5/16" / 1/4"	.127 / .130 cap. tube
621	032143-00	20g XH9	1" w/ double inlet	9"	5/16" / 1/4"	.127 / .130 cap. tube
CO73S	032145-00	28g XH9	1 5/8" directional	4 3/8"	3/8" ID	3/8" ID

MRO Model No.	Part No.	Recommended Tonnages				
		R-22 R-402	R-134a	R-401A/B	R-404A R-502, R-507A	R-410A
MMS-80	058070-01	1/3 to 2 tons depending on application and system. Contact Parker for details.				
MMS-100	058198-01					
MMS-200	032134-01					
712	032092-00					
319	032144-00					
619	032142-00					
620	032133-00					
621	032143-00					
CO73S	032145-00	4	4	4 1/2	3	4 1/2

Copper Service Dryer Water Capacity

MRO Part No.	OEM Part No.	R-12		R-22		R-134a		R-401A/B		R-401C		R-402A		R-402B	
		75°F	125°F	75°F	125°F	75°F	125°F	75°F	125°F	75°F	125°F	75°F	125°F	75°F	125°F
MMS-80	058070-01	33.0	30.6	29.8	27.4	32.6	31.0	32.6	30.2	30.6	28.8	33.2	30.6	33.0	30.4
MMS-100	058198-01	33.0	30.6	29.8	27.4	32.6	31.0	32.6	30.2	30.6	28.8	33.2	30.6	33.0	30.4
MMS-200	032134-01	66.0	61.2	59.6	54.8	65.2	62.0	65.2	60.4	61.2	57.6	66.4	61.2	66.0	60.8
712	032092-00	33.0	30.6	29.8	27.4	32.6	31.0	32.6	30.2	30.6	28.8	33.2	30.6	33.0	30.4
319	032144-00	99.0	91.8	89.4	82.2	97.8	93.0	97.8	90.6	91.8	86.4	99.6	91.8	99.0	91.2
619	032142-00	33.0	30.6	29.8	27.4	32.6	31.0	32.6	30.2	30.6	28.8	33.2	30.6	33.0	30.4
620	032133-00	66.0	61.2	59.6	54.8	65.2	62.0	65.2	60.4	61.2	57.6	66.4	61.2	66.0	60.8
621	032143-00	66.0	61.2	59.6	54.8	65.2	62.0	65.2	60.4	61.2	57.6	66.4	61.2	66.0	60.8
CO73S	032145-00	92.4	85.7	83.4	76.7	91.3	86.8	91.3	84.6	85.7	80.6	93.0	85.7	92.4	85.1

MRO Part No.	OEM Part No.	R-404A		R-407A		R-407B		R-407C		R-410A		R-502		R-507A	
		75°F	125°F	75°F	125°F	75°F	125°F	75°F	125°F	75°F	125°F	75°F	125°F	75°F	125°F
MMS-80	058070-01	32.8	30.6	24.2	22.2	24.2	22.2	26.2	23.6	19.8	17.4	30.4	28.6	32.8	30.8
MMS-100	058198-01	32.8	30.6	24.2	22.2	24.2	22.2	26.2	23.6	19.8	17.4	30.4	28.6	32.8	30.8
MMS-200	032134-01	65.6	61.2	48.4	44.4	48.4	44.4	52.4	47.2	39.6	34.8	60.8	57.2	65.6	61.6
712	032092-00	32.8	30.6	24.2	22.2	24.2	22.2	26.2	23.6	19.8	17.4	30.4	28.6	32.8	30.8
319	032144-00	98.4	91.8	72.6	66.6	72.6	66.6	78.6	70.8	59.4	52.2	91.2	85.8	98.4	92.4
619	032142-00	32.8	30.6	24.2	22.2	24.2	22.2	26.2	23.6	19.8	17.4	30.4	28.6	32.8	30.8
620	032133-00	65.6	61.2	48.4	44.4	48.4	44.4	52.4	47.2	39.6	34.8	60.8	57.2	65.6	61.6
621	032143-00	65.6	61.2	48.4	44.4	48.4	44.4	52.4	47.2	39.6	34.8	60.8	57.2	65.6	61.6
CO73S	032145-00	91.8	85.7	67.8	62.2	67.8	62.2	73.4	66.1	55.4	48.7	85.1	80.1	91.8	86.2

Copper Filter Dryer with Activated Alumina Core

- Activated alumina core provides excellent system filtration.
- Excellent for removing sludge and acids.

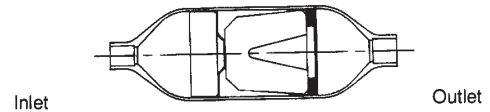

Part No.	Design Working Pressure PSI	Filtration Capacity Microns	Inlet In.	Outlet In.	Screen Area Sq. In.	Overall Length In.
057945-00	450	30	1/4	5/16	0.94	3.69
057945-02	450	30	.383 / .378	.383 / .378	0.94	3.69

Copper Filter Dryer with Activated Alumina Core Water Capacities

Part No.	R-12		R-22		R-134a		R-401A/B		R-401C		R-402A/B	
	75° F	125° F	75° F	125° F	75° F	125° F	75° F	125° F	75° F	125° F	75° F	125° F
057945-00	11.7	9.2	10.9	8.6	10.8	10.2	10.5	9.5	10.2	9.4	10.7	9.7
057945-02	11.7	9.2	10.9	8.6	10.8	10.2	10.5	9.5	10.2	9.4	10.7	9.7

Part No.	R-404A		R-407A/B		R-407C		R-410A		R-502		R-507A	
	75° F	125° F	75° F	125° F	75° F	125° F	75° F	125° F	75° F	125° F	75° F	125° F
057945-00	10.7	10.1	7.1	6.4	7.5	6.8	5.8	5.2	10.0	7.7	10.8	10.1
057945-02	10.7	10.1	7.1	6.4	7.5	6.8	5.8	5.2	10.0	7.7	10.8	10.1

Steel Liquid Line Filter Dryers (LLD Series)

Key Features and Benefits

- High moisture and acid capacity. Maximum filtration capacity.
- Exceptional compatibility with new polyolester oils.
- Compatible with all existing and new refrigerants and blends including 134a, 401A/B, 402A/B, 404A, 407A/B/C, 410A, 502, 507A.
- Spring loaded 100% molecular sieve. For 410A, Parker recommends XH11 (consult Parker).
- Solid copper sweat fittings.
- Powder paint exterior coating surpasses 500 hour ASTM salt spray test and resists corrosion.
- Eliminates concern of additive stripping.
- 032 MF liquid line dryer features 1/4" SAE steel flare male inlet and 1/4" SAE steel female flare outlet. Consult Parker for other sizes.
- 500 psig design pressure (600 psig available on all models designed for R-410A applications with XH11 desiccant.
- Extended copper ends available (select models).
- Available with other dessicant combinations including charcoal and activated alumina (consult Parker).
- Various inlet/outlet fitting combinations available.
- U.L. listed SA3441, CSA certified LR46423.
- **NOTE:** For R-410A applications, Parker recommends XH11 desiccant. See pages 9-11 for R-410A dryer information.



Steel Liquid Line Dryers - Water Drop Capacity at ARI Conditions

Model Series	R-12 (15 ppm) 75°F/125°F	R-22 (60 ppm) 75°F/125°F	R-134a (150 ppm) 75°F/125°F	R-401A/B (60 ppm) 75°F/125°F	R-401C (60 ppm) 75°F/125°F	R-402A/B (60 ppm) 75°F/125°F	R-404A (50 ppm) 75°F/125°F	R-407A/B (50 ppm) 75°F/125°F	R-407C (50 ppm) 75°F/125°F	R-410A* (50 ppm) 75°F/125°F	R-502 (30 ppm) 75°F/125°F	R-507A (50 ppm) 75°F/125°F
030	79/76	71/66	78/74	76/69	74/68	77/70	78/73	51/46	55/49	42/37	73/68	78/73
050	162/157	147/135	160/153	157/142	153/141	159/144	160/150	105/95	112/101	86/77	149/141	161/151
080	245/237	222/205	243/231	237/215	231/213	241/218	241/227	159/144	170/153	131/117	226/213	244/228
160	476/461	430/398	471/448	461/418	448/413	467/423	468/441	309/280	330/297	254/226	438/413	473/443
300	835/808	755/698	826/786	808/733	786/724	819/742	822/773	543/491	579/521	446/397	769/724	830/777
410	1164/1127	1053/973	1151/1096	1127/1022	1096/1010	1142/1034	1145/1078	757/684	806/726	622/554	1071/1010	1158/1084
750	1776/1720	1607/1485	1757/1673	1720/1560	1673/1541	1743/1579	1748/1645	1156/1044	1231/1109	949/846	1635/1541	1767/1654

*See pages 9-11 for R-410A specific dryers and applications.

Refrigerant Holding Capacities for Steel Liquid Line Dryers

(in oz. of refrigerant @ 100° F)

Model Series	R-12	R-22	R-134a	R-401A/B	R-401C	R-402A	R-402B	R-404A	R-407A	R-407B	R-407C	R-410A	R-502	R-507A
030	1.92	1.74	1.76	1.71	1.51	1.59	1.42	1.49	1.64	1.46	1.45	1.52	1.76	1.50
050	5.60	5.07	5.13	4.99	4.39	4.62	4.31	4.35	4.78	4.44	4.38	4.42	5.12	4.35
080	7.97	7.21	7.30	7.10	6.24	6.58	6.10	6.18	6.81	6.27	6.20	6.28	7.28	6.19
160	8.87	8.02	8.12	7.89	6.94	7.31	6.28	6.88	7.57	6.46	6.38	6.99	8.10	6.89
300	26.73	24.17	24.47	23.79	20.92	22.04	20.43	20.73	22.82	21.01	20.75	21.07	24.42	20.77
410	37.33	33.75	34.17	33.22	29.21	30.78	28.53	28.95	31.86	29.34	28.98	29.42	34.10	29.00
750	71.32	64.48	65.29	63.47	55.81	58.81	55.62	55.31	60.88	57.20	56.49	56.21	65.15	55.41

Steel Liquid Line Dryer Dimensions

Model No.	Connections		System Cutout Length (C)	Diameter in Inches (D)	Overall Length Inches	Model No.	SAE Flare (A)	System Cutout Length (B)	Diameter in Inches (C)
	I.D. (A)	O.D. (B)							
032S	1/4	3/8	2 9/16	1 11/16	3.77	032	1/4	4 1/8	1 11/16
						032MF	1/4	3 29/32	1 11/16
052S	1/4	3/8		2 1/2	4.39	052	1/4	4 3/4	2 1/2
0525S	5/16	7/16	3 1/4		4.39				
053S	3/8	1/2		2 1/2	4.39	053	3/8	5 3/16	2 1/2
082S	1/4	3/8		2 1/2	5.27	082	1/4	5 5/8	2 1/2
0825S	5/16	7/16			5.27				
083S	3/8	1/2		2 1/2	5.27	083	3/8	6 1/16	2 1/2
084S	1/2	5/8	4 1/8	2 1/2	5.41	084	1/2	6 5/16	2 1/2
162S	1/4	3/8		2 1/2	5.92	162	1/4	6 5/16	2 1/2
1625S	5/16	7/16			5.92				
163S	3/8	1/2	4 3/4	2 1/2	5.92	163	3/8	6 3/4	2 1/2
164S	1/2	5/8		2 1/2	6.06	164	1/2	7	2 1/2
165S	5/8	3/4		2 1/2	6.3	165	5/8	7 1/4	2 1/2
303S	3/8	1/2		3	8.86	303	3/8	9 11/16	3
304S	1/2	5/8		3	9	304	1/2	9 15/16	3
305S	5/8	3/4		3	9.24	305	5/8	10 3/16	3
307S	7/8	1	7 3/4	3	9.3				3
414S	1/2	5/8		3 1/2	9.19	413	3/8	9 7/8	3 1/2
415S	5/8	3/4	7 3/4	3 1/2	9.43	414	1/2	10 1/8	3 1/2
417S	7/8	1		3 1/2	9.49	415	5/8	10 3/8	3 1/2
756S	3/4	7/8		3 1/2	15.11				
757S	7/8	1	13 9/16	3 1/2	15.11				
759S	1 1/8	1 1/4		3 1/2	15.99				

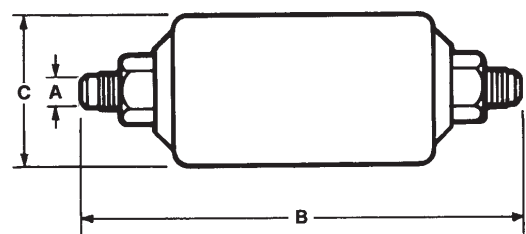
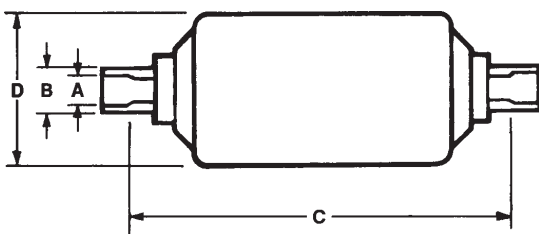

Steel Liquid Line Dryers Flow Capacity (tons of refrigerant) at pressure drop 1 psi

Model No.	Filter Area	R-12	R-22	R-134a	R-401A	R-401B	R-401C	R-402A	R-402B	R-404A	R-407A	R-407B	R-407C	R-410A*	R-502	R-507A
032	10	1.27	1.70	1.54	1.74	1.75	1.55	1.14	1.34	1.10	1.48	1.19	1.64	1.67	1.11	1.10
032S		1.41	1.84	1.72	1.93	1.95	1.72	1.27	1.48	1.22	1.65	1.32	1.82	1.86	1.23	1.23
032MF		1.27	1.70	1.54	1.74	1.75	1.55	1.14	1.34	1.10	1.48	1.19	1.64	1.67	1.11	1.10
052	17	1.41	1.84	1.72	1.93	1.95	1.72	1.27	1.48	1.22	1.65	1.32	1.82	1.86	1.23	1.23
052S		1.48	2.05	1.80	2.03	2.04	1.80	1.34	1.56	1.29	1.73	1.39	1.91	1.95	1.29	1.29
0525S		2.47	3.32	3.00	3.38	3.40	3.01	2.23	2.60	2.14	2.88	2.31	3.19	3.25	2.15	2.15
053		2.97	3.96	3.60	4.06	4.08	3.61	2.67	3.12	2.57	3.46	2.78	3.83	3.90	2.58	2.57
053S	3.54	4.74	4.29	4.83	4.86	4.30	3.18	3.71	3.06	4.12	3.31	4.56	4.64	3.07	3.06	
082	27	1.41	1.84	1.72	1.93	1.95	1.72	1.27	1.48	1.22	1.65	1.32	1.82	1.86	1.23	1.23
082S		1.56	2.12	1.89	2.13	2.14	1.89	1.40	1.63	1.35	1.81	1.46	2.01	2.04	1.35	1.35
0825S		2.62	3.46	3.17	3.58	3.60	3.18	2.35	2.74	2.27	3.05	2.45	3.37	3.43	2.27	2.27
083		3.32	4.45	4.03	4.54	4.57	4.04	2.99	3.49	2.88	3.87	3.11	4.28	4.36	2.89	2.88
083S		3.75	5.02	4.54	5.12	5.15	4.55	3.37	3.93	3.25	4.37	3.51	4.83	4.92	3.26	3.25
084		5.30	7.14	6.43	7.25	7.29	6.44	4.77	5.56	4.59	6.18	4.96	6.84	6.96	4.61	4.60
084S		5.37	7.21	6.52	7.35	7.39	6.53	4.83	5.64	4.65	6.26	5.03	6.93	7.05	4.67	4.66
162	34	1.63	2.19	1.97	2.22	2.24	1.98	1.46	1.71	1.41	1.89	1.52	2.10	2.13	1.41	1.41
162S		1.77	2.40	2.14	2.42	2.43	2.15	1.59	1.85	1.53	2.06	1.65	2.28	2.32	1.54	1.53
1625S		3.04	4.03	3.69	4.16	4.18	3.69	2.74	3.19	2.63	3.54	2.84	3.92	3.99	2.64	2.64
163		3.96	5.30	4.80	5.41	5.45	4.81	3.56	4.15	3.43	4.61	3.70	5.10	5.20	3.44	3.43
163S		4.38	5.94	5.32	5.99	6.03	5.33	3.94	4.60	3.80	5.11	4.10	5.65	5.75	3.81	3.80
164		6.72	9.05	8.15	9.18	9.24	8.16	6.04	7.05	5.82	7.83	6.28	8.66	8.81	5.84	5.82
164S		7.28	9.83	8.83	9.96	10.02	8.85	6.55	7.64	6.31	8.49	6.81	9.39	9.56	6.33	6.31
165		9.40	12.58	11.40	12.86	12.94	11.43	8.46	9.87	8.15	10.96	8.80	12.12	12.34	8.17	8.15
165S		9.69	13.01	11.75	13.24	13.32	11.77	8.71	10.16	8.39	11.29	9.06	12.49	12.71	8.42	8.40
166		11.03	14.78	13.38	15.08	15.17	13.40	9.92	11.57	9.55	12.85	10.32	14.22	14.47	9.59	9.56
303	61	4.03	5.44	4.89	5.51	5.54	4.90	3.63	4.23	3.49	4.70	3.77	5.19	5.29	3.50	3.49
303S		4.60	6.15	5.57	6.28	6.32	5.59	4.13	4.82	3.98	5.35	4.30	5.92	6.03	3.99	3.98
304		7.99	10.75	9.69	10.92	10.99	9.71	7.19	8.38	6.92	9.31	7.47	10.30	10.48	6.94	6.93
304S		9.26	12.44	11.23	12.66	12.74	11.26	8.33	9.72	8.02	10.79	8.66	11.94	12.15	8.05	8.03
305		10.96	14.71	13.29	14.98	15.07	13.32	9.86	11.50	9.49	12.77	10.25	14.13	14.38	9.52	9.50
305S		12.09	16.26	14.66	16.53	16.63	14.69	10.88	12.69	10.47	14.09	11.31	15.58	15.86	10.51	10.48
306		12.30	16.47	14.92	16.82	16.92	14.95	11.07	12.91	10.66	14.33	11.51	15.86	16.14	10.69	10.67
307S		14.99	20.15	18.18	20.49	20.62	18.22	13.48	15.73	12.98	17.46	14.02	19.32	19.67	13.03	13.00
413	80	4.03	5.44	4.89	5.51	5.54	4.90	3.63	4.23	3.49	4.70	3.77	5.19	5.29	3.50	3.49
414		8.06	10.82	9.78	11.02	11.09	9.80	7.25	8.46	6.98	9.39	7.54	10.39	10.58	7.01	6.99
414S		9.26	12.44	11.23	12.66	12.74	11.26	8.33	9.72	8.02	10.79	8.66	11.94	12.15	8.05	8.03
415		10.96	14.71	13.29	14.98	15.07	13.32	9.86	11.50	9.49	12.77	10.25	14.13	14.38	9.52	9.50
415S		12.09	16.26	14.66	16.53	16.63	14.69	10.88	12.69	10.47	14.09	11.31	15.58	15.86	10.51	10.48
417S	17.18	23.12	20.84	23.49	23.63	20.88	15.46	18.03	14.88	20.02	16.07	22.15	22.54	14.93	14.90	
756S	131	14.63	19.65	17.75	20.01	20.13	17.79	13.17	15.36	12.68	17.05	13.69	18.87	19.20	12.72	12.69
757S		18.17	24.32	22.04	24.84	24.99	22.08	16.35	19.07	15.74	21.17	17.00	23.42	23.84	15.79	15.75
759S		20.01	26.80	24.27	27.36	27.52	24.32	18.00	20.99	17.33	23.31	18.72	25.79	26.26	17.39	17.35

*Specific models have been designed for use with R-410A. See pages 9-11 for R-410A specific dryers and applications.

Steel Liquid Line Dryers - Installation Recommendations (Nominal Tons)

Selection Recommendations (Nominal Ratings - tons)												
Model No.	Refrigeration						Air Conditioning					
	Commercial Low Temp. Equipment						OEM, Self-Contained/Field Replacement					
	12 134a 401A	22 402	404A 502 507A	407C 410A	407A	407B	134a 401A	22 402 410A	404A 502 507A	407A	407B	407C
032	1/2	1/2	1/2	1/2	1/2	1/2	1	1 1/2	1	1	1	1 1/2
032S												
032MF												
052	3/4	3/4	1/2	3/4	3/4	3/4	1	1 1/2	1	1	1	1 1/2
052S												
0525S	1	1	3/4	1	1	1	2	2 1/2	2	2	2	2 1/2
053	1 1/2	2	1 1/2	1 1/2	2	2	3	4	3	3	3	4
053S												
082	1 1/2	1	3/4	1 1/2	1	1	1 1/2	2	1 1/2	1 1/2	1 1/2	2
082S												
0825S		2	1	1	2	2	3	4	3	3	3	4
083	2	3	2	2	3	2	4	5	3	4	4	5
083S												
084		4	2	2	4	2	5	7 1/2	4	5	5	7 1/2
084S												
162	1 1/2	2	1	1 1/2	2	1	1 1/2	2	1.5	2	1 1/2	2
162S												
1625S	2	3	2	2	3	2	3	4	3	3 1/2	3	4
163	3	5	3	3	4	3	4	5	4	5	4	5
163S												
164	3	5	3	3	5	3	5	10	5	5	5	7 1/2
164S												
165		7.5	3	3	7.5	3	7 1/2	15	7 1/2	7 1/2	7 1/2	10
165S												
303	4	5	3	4	5	3	4	6	4	5	5	5
303S												
304	4	7 1/2	4	4	7 1/2	5	7 1/2	12	7 1/2	10	7 1/2	10
304S												
305	7 1/2	10	5	5	7 1/2	5	10	15	10	12 1/2	10	15
305S												
307S		15	5	5	10	5	18	24	12 1/2	15	12 1/2	20
413	4	5	4	5	5	4	5	7 1/2	5	5	5	5
414												
414S			5	5	5	5	7 1/2	12	7 1/2	10	7 1/2	10
415	10	7 1/2	7 1/2	7 1/2	7 1/2	10	12 1/2	18	10	15	12 1/2	18
415S												
417S		10	7 1/2	7 1/2	10	10	18	25	15	24	18	25
756S	15	20	15	15	20	12 1/2	15	25	15	20	15	25
757S	20	25	15	15	20	15	22	30	18	25	20	30
759S	22	30	20	18	25	20	25	34	20	28	22	32

Copper Liquid Line Solid Core Dryer (Cu LLD® Series)

Key Features and Benefits

- Solid core 100% molecular sieve dryer.
- Super high moisture/acid capacity. Large flow capacity.
- Compatible with all new and existing refrigerants and blends.
- All copper body is corrosion resistant.
- U.L. recognized and CSA certified.



Copper Liquid Line Dryers - Water Drop Capacity at ARI Conditions

MRO Model No.	OEM Model No.	R-12 (15 ppm) 75°F/125°F	R-22 (60 ppm) 75°F/125°F	R-134a (50 ppm) 75°F/125°F	R-401A/B (50 ppm) 75°F/125°F	R-401C (50 ppm) 75°F/125°F	R-402A (50 ppm) 75°F/125°F	R-402B (50 ppm) 75°F/125°F
Cu LLD 2-3S	s13	31/28	28/24	31/27	30/26	29/25	30/26	30/26
Cu LLD 3-2S	s22	69/63	63/55	69/62	67/57	65/57	68/58	68/58
Cu LLD 3-3S	s23	69/63	63/55	69/62	67/57	65/57	68/58	68/58
Cu LLD 5-3S	s33	95/87	86/75	94/85	92/79	90/78	94/80	94/80
Cu LLD 8-3S	s53	166/152	150/131	165/147	161/137	157/136	163/139	163/139
Cu LLD 16-3S	s83	266/242	241/209	263/236	258	258/20	251/217	261/223

MRO Model No.	OEM Model No.	R-404A (50 ppm) 75°F/125°F	R-407A (50 ppm) 75°F/125°F	R-407B (50 ppm) 75°F/125°F	R-407C (50 ppm) 75°F/125°F	R-410A (50 ppm) 75°F/125°F	R-502 (50 ppm) 75°F/125°F	R-507A (50 ppm) 75°F/125°F
Cu LLD 2-3S	s13	30/27	20/17	20/17	21/18	17/14	28/25	31/27
Cu LLD 3-2S	s22	68/61	45/38	45/38	48/41	37/31	64/57	69/61
Cu LLD 3-3S	s23	68/61	45/38	45/38	48/41	37/31	64/57	69/61
Cu LLD 5-3S	s33	94/83	62/53	62/53	66/56	51/43	88/78	95/84
Cu LLD 8-3S	s53	164/145	108/92	338/78	115/98	89/75	153/136	165/146
Cu LLD 16-3S	s83	261/223	262/232	173/147	173/147	142/119	245/217	265/233

Refrigerant Holding Capacities for Copper Liquid Line Core Dryers

(in oz. of refrigerant @ 100°F)

MRO Model No.	OEM Model No.	R12	R22	R134a	R401A/B	R401C	R402A	R402B	R404A	R407A	R407B	R407C	R410A	R502	R507A
Cu LLD 2-3S	s13	1.37	1.24	1.25	1.22	1.07	1.13	1.15	1.06	1.17	1.18	1.17	1.08	1.25	1.06
Cu LLD 3-2S	s22	2.82	2.55	2.58	2.51	2.21	2.33	2.38	2.19	2.41	2.44	2.41	2.23	2.58	2.19
Cu LLD 3-3S	s23	2.82	2.55	2.58	2.51	2.21	2.33	2.38	2.19	2.41	2.44	2.41	2.23	2.58	2.19
Cu LLD 5-3S	s33	3.52	3.18	3.22	3.13	2.76	2.90	2.96	2.73	3.01	3.05	3.01	2.78	3.22	2.74
Cu LLD 8-3S	s53	6.35	5.74	5.81	5.65	4.97	5.24	5.34	4.93	5.42	5.50	5.43	5.01	5.80	4.93
Cu LLD 16-3S	s83	6.91	6.25	6.33	6.15	5.41	5.70	5.82	5.36	5.90	5.98	5.91	5.45	6.32	5.37

Copper Liquid Line Dryers - Installation Recommendations (Nominal Tons)

		Selection Recommendations (Nominal Ratings - tons)											
OEM Model	MRO Model	Refrigeration						Air Conditioning					
		Commercial Low Temp. Equipment						OEM, Self-Contained/Field Replacement					
		12 134a 401A	22 402	404A 502 507A	407C 410A	407A	407B	134a 401A	22 402 410A	404A 502 507A	407A	407B	407C
s13	Cu LLD 2-3S	1	1	3/4	1 1/4	1	3/4	2	2	1 1/2	2	1 3/4	1 1/2
s22	Cu LLD 3-2S	3/4	3/4	1/2	3/4	1/2	3/4	1 1/2	1 1/2	1	1 3/4	1	1 1/2
s23	Cu LLD 3-3S	1 3/4	1 1/2	1 3/4	1 3/4	1 3/4	1 3/4	3 1/2	3	2 1/2	3 1/2	2 1/2	3 1/2
s33	Cu LLD 5-3S	1 3/4	1 1/2	1 3/4	1 3/4	1 1/2	1 3/4	3 1/2	3	2 1/2	3	2 1/2	3 1/2
s53	Cu LLD 8-3S	2	1 1/2	1 3/4	2	1 3/4	1 1/2	3 1/2	3	2 1/2	3 1/2	3	4
s83	Cu LLD 16-3S	2	1 1/2	1 3/4	2	1 3/4	1 1/2	4	3 1/2	2 1/2	3 1/2	3	4

Copper Liquid Line Dryers - Tons of Refrigerant at Pressure Drop 1 psi

OEM model	MRO model	R-12	R-22	R-134a	R-401A	R-401B	R-401C	R-402A	R-402B	R-404A	R-407A	R-407B	R-407C	R410A	R-502	R-507A
s13	Cu LLD 2-3S	2.2	2.9	2.6	2.9	3.0	2.7	2.0	2.3	1.9	2.6	2.1	2.9	2.8	1.9	1.9
s22	Cu LLD 3-2S	1.4	1.9	1.7	1.8	1.9	1.7	1.3	1.5	1.2	1.6	1.3	1.8	1.8	1.2	1.2
s23	Cu LLD 3-3S	3.2	4.3	3.9	4.3	4.4	3.9	2.9	3.4	2.8	3.7	3.0	4.2	4.2	2.8	2.8
s33	Cu LLD 5-3S	3.1	4.2	3.8	4.1	4.3	3.8	2.8	3.3	2.7	3.6	2.9	4.1	4.1	2.7	2.7
s53	Cu LLD 8-3S	3.4	4.6	4.2	4.5	4.7	4.1	3.1	3.6	3.0	4.0	3.2	4.5	4.5	3.0	3.0
s83	Cu LLD 16-3S	3.6	4.8	4.4	4.7	5.0	4.4	3.2	3.8	3.1	4.2	3.4	4.7	4.6	3.1	3.1

Bi-flow Filter Dryers - BF Series

The "BF" Series bi-flow dryer is designed specifically for heat pump or reverse cycle application. External check valves are not required since they are incorporated within the filter dryer shell. The core design filters out contaminant particles down to 25 microns.



Key Features and Benefits

- 100% copper sweat or nickel plated flare fittings.
- Dessicant core provides reliable and effective removal of solid contaminants, acid and moisture.
- Model BF-163S-XF features XH11 desiccant design for R-410A applications. Provides three times the filtration as the standard bi-flow.
- Core is cushioned in fiber gaskets to protect core and to insure trouble-free performance.
- Powder paint exterior coating surpasses 500 hour ASTM salt spray test and resists corrosion.
- U.L. listed file SA3441, CSA certified LR46423

Bi-flow Dryers - Dimensions

Model Number		Fitting Size (Inches)	System	System	System	"D"
Flare	Sweat		Cutout Length "A"	Cutout Length "B"	Cutout Length "C"	
	BF082S	1/4		4.10	5.27	2.50
BF083	BF083S	3/8	6.09	4.10	5.27	2.50
BF084	BF084S	1/2	6.35	4.10	5.41	2.50
	BF162S	1/4		4.10	5.92	2.50
BF163	BF163S	3/8	6.75	4.75	5.92	2.50
	<i>BF163S-XF*</i>	3/8	6.09	6.76	7.56	3.00
BF164	BF164S	1/2	7.00	4.75	6.06	2.50
	BF165S	5/8		4.75	6.30	2.50

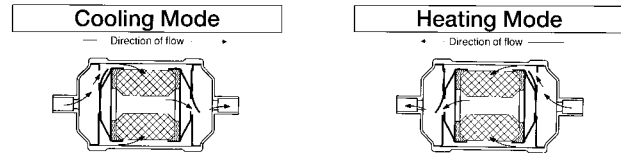
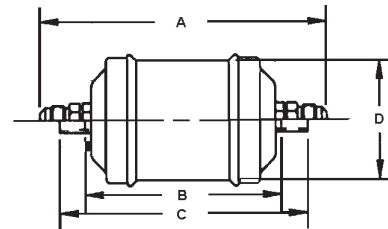

Refrigerant Holding Capacities for Bi-Flow Dryers (in oz. of refrigerant @ 100° F)

Model Series	R-12	R-22	R-134a	R-401A	R-401B	R-401C	R-402A	R-402B	R-404A	R-407A	R-407B	R-407C	R-410A	R-502	R-507A
BF080	8.17	7.39	7.48	7.27	7.27	6.39	6.74	6.87	6.34	6.97	7.07	6.98	6.44	7.46	6.34
BF160	9.54	8.63	8.74	8.49	8.49	7.47	7.87	8.03	7.40	8.14	8.26	8.16	7.52	8.72	7.41
<i>BF160-XF*</i>	15.47	13.99	14.16	13.77	13.77	12.11	12.76	13.02	12.00	13.20	13.39	13.22	12.19	14.15	12.01

Bi-flow Dryer Water Drop Capacity at ARI Conditions

Model Series	R-12 (15 ppm) 75°F/125°F	R-22 (60 ppm) 75°F/125°F	R-134a (150 ppm) 75°F/125°F	R-401A/B (50 ppm) 75°F/125°F	R-401C (50 ppm) 75°F/125°F	R-402A (50 ppm) 75°F/125°F	R-402B (50 ppm) 75°F/125°F
BF080	105/102	95/88	104/99	102/92	99/91	103/93	103/93
BF160	148/144	134/124	147/140	144/130	140/129	146/132	146/132
<i>BF160-XF*</i>	186/180	168/155	184/175	180/163	175/161	182/165	182/165

Model Series	R-404A (50 ppm) 75°F/125°F	R-407A (50 ppm) 75°F/125°F	R-407B (50 ppm) 75°F/125°F	R-407C (50 ppm) 75°F/125°F	R-410A (50 ppm) 75°F/125°F	R-502 (50 ppm) 75°F/125°F	R-507A (50 ppm) 75°F/125°F
BF080	103/97	68/62	68/62	73/65	56/50	97/91	104/98
BF160	146/137	97/87	97/87	103/93	79/71	137/129	148/138
<i>BF160-XF*</i>	183/172	142/128	142/128	197/176	197/176*	171/161	185/173

*NOTE: Model Series BF160-XF is recommended for R-410A applications.

Bi-Flow Dryer Flow Capacity - Tons of Refrigerant at Pressure Drop 1 PSI

Model No.	Filter Area cu inches	R-12	R-22	R-134a	R-401A	R-401B	R-401C	R-402A	R-402B	R-404A	R-407A	R-407B	R-407C	R-410A	R-502	R-507A
BF082S	10.4	1.6	2.1	1.9	2.2	2.2	1.9	1.4	1.7	1.4	1.9	1.5	2.0	2.1	1.4	1.4
BF083S		2.1	2.8	2.6	2.9	2.9	2.6	1.9	2.2	1.8	2.5	2.0	2.7	2.8	1.8	1.8
BF084S		2.7	3.5	3.2	3.6	3.6	3.2	2.4	2.8	2.3	3.1	2.5	3.4	3.5	2.3	2.3
BF083		2.1	2.8	2.6	2.9	2.9	2.6	1.9	2.2	1.8	2.5	2.0	2.7	2.8	1.8	1.8
BF084		2.7	3.5	3.2	3.6	3.6	3.2	2.4	2.8	2.3	3.1	2.5	3.4	3.5	2.3	2.3
BF162S	14.4	1.6	2.1	1.9	2.2	2.2	1.9	1.4	1.7	1.4	1.9	1.5	2.0	2.1	1.4	1.4
BF163S		2.2	2.9	2.6	3.0	3.0	2.6	2.0	2.3	1.9	2.5	2.0	2.8	2.9	1.9	1.9
BF164S		2.7	3.5	3.2	3.6	3.6	3.2	2.4	2.8	2.3	3.1	2.5	3.4	3.5	2.3	2.3
BF165S		3.7	4.9	4.5	5.1	5.1	4.5	3.3	3.9	3.2	4.3	3.5	4.8	4.9	3.2	3.2
BF163		2.1	2.8	2.6	2.9	2.9	2.6	1.9	2.2	1.8	2.5	2.0	2.7	2.8	1.8	1.8
BF164		2.7	3.5	3.2	3.6	3.6	3.2	2.4	2.8	2.3	3.1	2.5	3.4	3.5	2.3	2.3
BF163S-XF		2.7	3.6	3.3	3.7	3.7	3.3	2.4	2.8	2.3	3.1	2.5	3.5	3.5	2.3	2.3

Copper Bi-flow Filter Dryers - CBF Series

Key Features and Benefits

- Desiccant core provides reliable and effective removal of solid contaminants, acid and moisture.
- All copper construction is corrosion resistant.



Copper BiFlow Dryer Data

Part Number	Overall Length	Core	Inlet/Outlet
032284-052	7.04	3 cu in core	1/4" inlet and outlet
032284-053	7.04	3 cu in core	3/8" inlet and outlet
032284-082	7.98	5 cu in core	1/4" inlet and outlet
032284-083	7.98	5 cu in core	3/8" inlet and outlet
032284-084	7.98	5 cu in core	1/2" inlet and outlet
032284-085	7.98	5 cu in core	5/8" inlet and outlet
032284-162	9.55	8 cu in core	1/4" inlet and outlet
032284-163	9.55	8 cu in core	3/8" inlet and outlet
032284-164	9.55	8 cu in core	1/2" inlet and outlet
032284-165	9.55	8 cu in core	5/8" inlet and outlet

All of these dryers have a .01-.02 tube stop in the inlet and outlet.

Refrigerant Internal Holding Capacities for Copper Bi-Flow Dryers

(in oz. of refrigerant @ 100° F)

Part No.	R-12	R-22	R-134a	R-401A/B	R-401C	R-402A	R-402B	R-404A	R-407A	R-407B	R-407C	R-410A	R-502	R-507A
032284-050	7.16	6.47	6.55	6.37	5.60	5.90	6.02	5.55	6.11	6.20	6.12	5.64	6.54	5.56
032284-080	9.05	8.18	8.28	8.05	7.08	7.46	7.61	7.02	7.72	7.83	7.73	7.13	8.27	7.03
032284-160	11.15	10.08	10.21	9.92	8.73	9.19	9.38	8.65	9.52	9.65	9.53	8.79	10.18	8.66

Copper Bi-flow Dryer Water Drop Capacity at ARI Conditions

Part No.	R-12 (15 ppm)	R-22 (60 ppm)	R-134a (150 ppm)	R-401A (50 ppm)	R-402A/B (50 ppm)	R-404A (50 ppm)	R-407A (50 ppm)	R-407B (50 ppm)	R-407C (50 ppm)	R-410A (50 ppm)	R-502 (50 ppm)	R-507A (50 ppm)
032284-050	143/130	129/112	141/127	138/118	140/120	141/124	93/79	93/79	101/84	81/64	132/117	142/125
032284-080	229/209	207/180	226/202	221/189	224/191	225/199	149/126	149/126	161/134	129/102	210/187	227/200
032284-160	358/326	323/281	353/316	345/295	350/298	351/311	232/197	232/197	251/210	202/160	328/291	355/312

Copper Suction Line Dryer (Cu SLD® Series)

- High-acid solid core design.
- Flow capacities from 1/6 through 2 1/2 tons.
- Access valve to check system pressure or charge through.
- Applications include refrigerators, freezers, ductless A/C and PTAC units.



Copper Suction Line Dryer Data

Model No.	Maximum Flow Rate						System	Cutout Length
	22 402	134a	401A/B	404A 502, 507	407A/B	410A	O.A. Length	
Cu SLD 5/16	1/3	1/4	1/4	1/3	1/3	1/2	5.31"	4.63"
Cu SLD-3S	2 1/2	2	2	2	2 1/2	2 1/2	6.71"	6.00"
Cu SLD-4S	2 1/2	2	2	1 1/2	2 1/2	2 1/2	6.71"	6.00"

• NOTE: Model Cu SLD 5/16 is 100% XH6 molecular sieve. Models Cu SLD-3S & 4S are 50% XH6 molecular sieve and 50% activated alumina.

Copper Suction Line Dryer Water Capacity in Drops at 75°F

Model No.	Fitting type & size	R-12	R-22	R-134a	R-401A/B	R-401C	R-402A/B	R-404A	R-407A/B	R-407C	R-410A	R-502	R-507A
Cu SLD-5/16	5/16 Sweat	69.4	62.8	68.7	67.2	65.4	68.1	68.3	45.2	48.1	37.1	63.9	69
Cu SLD-3S	3/8 Sweat	107.8	97.5	106.6	104.3	101.5	105.8	106	70.1	74.7	57.6	99.2	107.2
Cu SLD-4S	1/2 Sweat	107.8	97.5	106.6	104.3	101.5	105.8	106	70.1	74.7	57.6	99.2	107.2

Steel Suction Line Filter Dryers - "The Original SLD®"

Parker Hannifin developed and introduced the solid-core clean-up dryer for use in a system suction line. The compact design incorporates a large outside diameter shell, which results in a shorter lay-in length, and a larger core, which provides a greater filtration area for maximum operating efficiency.

The core material has controlled porosity which effectively removes and holds a maximum amount of contaminants with a minimum of pressure drop. In addition, the core material collects and holds inorganic acids and other harmful contaminants present after a motor burnout. The special binding process protects the core from acid decomposition.

Access valves on both the inlet and outlet sides make it easy to measure pressure accurately. Occasionally,



enough contaminant matter may collect in the filter core to cause a slight pressure drop. The access valves on the SLD make it easy to determine if a pressure drop exists and to measure the amount of the drop.

Key Features and Benefits

- The original SLD®, solid core, activated alumina suction line filter dryer.
- High acid capacity.
- Low pressure drop -- exceptionally high flow rates.
- Designed for system clean-up.
- 500 hours salt spray protection.
- Shortest system cut-out lengths allow installation in tight areas.
- Two access valves simplify pressure drop measurement.
- Flare or solid copper sweat fittings.
- UL listed -- File No. SA3441. CSA listed LR46423.

Steel Suction Line Dryer Dimensions

Model No.	A Overall Length Inches	B System Cutout Length - Inches	Shell Diameter Inches
SLD 8-3V-HH	5.13	-	3
SLD 8-3SV-HH	4.31	3.13	3
SLD 8-4V-HH	5.38	-	3
SLD 8-4SV-HH	4.44	3.13	3
SLD 8-5SV-HH	4.66	3.16	3
SLD 8-6SV-HH	4.72	3.16	3
SLD 13-5V-HH	5.82	-	4
SLD 13-5SV-HH	4.91	3.45	4
SLD 13-6SV-HH	4.97	3.45	4
SLD 13-7SV-HH	4.97	3.47	4
SLD 13-9SV-HH	5.72	3.47	4
SLD 27-7SV-HH	6.97	5.47	4
SLD 27-9SV-HH	7.72	5.36	4
SLD 54-11SV-HH	12	9.17	4
SLD 54-13SV-HH	12	9.17	4

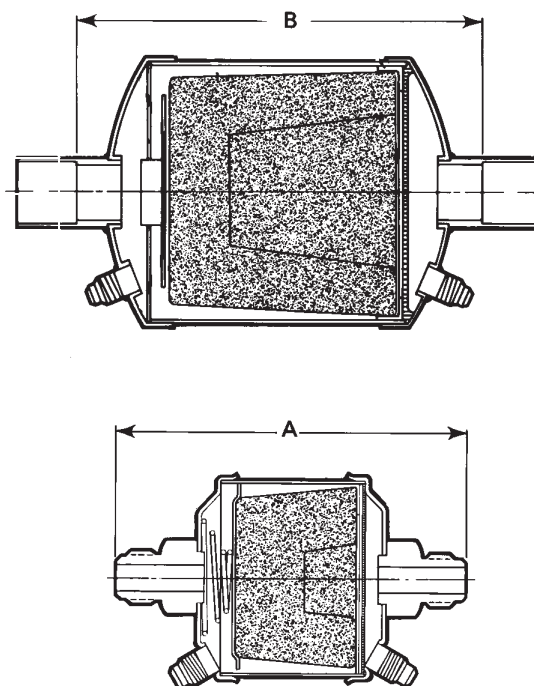

Steel Suction Line Dryer Water Drop Capacities at 65°F

Model No.	Fitting	Desiccant (Cu. In.)	Filter Area (Sq. In.)	22 & 404A	134a & 407	401A & 410A	502 & 507A
SLD 8-3V-HH	3/8" SAE Flare	8	17.25	168	168	200	185
SLD 8-3SV-HH	3/8" Sweat	8	17.25	168	168	200	185
SLD 8-4V-HH	1/2" SAE Flare	8	17.25	168	168	200	185
SLD 8-4SV-HH	1/2" Sweat	8	17.25	168	168	200	185
SLD 8-5SV-HH	5/8" Sweat	8	17.25	168	168	200	185
SLD 8-6SV-HH	3/4" Sweat	8	17.25	168	168	200	185
SLD 13-5V-HH	5/8" SAE Flare	13 1/2	26	284	284	338	312
SLD 13-5SV-HH	5/8" Sweat	13 1/2	26	284	284	338	312
SLD 13-6SV-HH	3/4" Sweat	13 1/2	26	284	284	338	312
SLD 13-7SV-HH	7/8" Sweat	13 1/2	26	284	284	338	312
SLD 13-9SV-HH	1 1/8" Sweat	13 1/2	26	284	284	338	312
SLD 27-7SV-HH	7/8" Sweat	27	49	568	568	676	624
SLD 27-9SV-HH	1 1/8" Sweat	27	49	568	568	676	624
SLD 54-11SV-HH	1 3/8" Sweat	54	88	1136	1136	1352	1248
SLD 54-13SV-HH	1 5/8" Sweat	54	88	1136	1136	1352	1248

Steel Suction Line Filter Dryer Ratings and Capacities

Refrigerant	22					134a				R-404A					R-407A & R-407C				
	40°F	20°F	0°F	-20°F	-40°F	40°F	20°F	0°F	-20°F	40°F	20°F	0°F	-20°F	-40°F	40°F	20°F	0°F	-20°F	-40°F
Pressure Drop PSI	3	2	1.5	1	0.5	2.0	1.5	1.0	0.5	3.0	2.0	1.5	1.0	0.5	3.0	2.0	1.5	1.0	0.5
SLD 8-3V-HH	1.1	0.8	0.6	0.4	0.2	0.7	0.6	0.5	0.4	1.0	0.7	0.5	0.3	0.3	1.1	0.8	0.6	0.4	0.2
SLD 8-3SV-HH	1.2	0.9	0.7	0.5	0.3	0.8	0.7	0.6	0.5	1.0	0.8	0.6	0.4	0.5	1.2	0.9	0.7	0.5	0.3
SLD 8-4V-HH	2.3	1.6	1.1	0.7	0.4	1.5	1.2	0.9	0.7	2.0	1.4	0.9	0.6	0.6	2.2	1.6	1.1	0.7	0.4
SLD 8-4SV-HH	2.6	1.8	1.2	0.8	0.5	1.7	1.4	1.0	0.8	2.3	1.5	1.0	0.6	0.8	2.5	1.8	1.2	0.8	0.5
SLD 8-5SV-HH	3.9	2.6	1.8	1.2	0.6	2.5	2.0	1.5	1.1	3.4	2.2	1.5	1.0	1.0	3.8	2.6	1.8	1.2	0.6
SLD 8-6SV-HH	4.2	2.8	1.9	1.3	0.6	2.7	2.1	1.6	1.2	3.6	2.4	1.6	1.0	1.0	4.1	2.8	1.9	1.3	0.6
SLD 13-5V-HH	4.1	2.7	2.0	1.3	0.8	2.6	2.0	1.7	1.2	3.6	2.3	1.6	1.0	1.3	4.0	2.7	2.0	1.3	0.8
SLD 13-5SV-HH	5.0	3.0	2.5	1.5	1.0	3.2	2.3	2.1	1.4	4.3	2.5	2.1	1.2	1.6	4.9	3.0	2.5	1.5	1.0
SLD 13-6SV-HH	7.0	4.5	3.0	2.0	1.0	4.5	3.4	2.5	1.9	6.1	3.8	2.5	1.6	1.6	6.8	4.5	3.0	2.0	1.0
SLD 13-7SV-HH	7.0	4.5	3.0	2.0	1.0	4.5	3.4	2.5	1.9	6.1	3.8	2.5	1.6	1.6	6.8	4.5	3.0	2.0	1.0
SLD 13-9SV-HH	7.2	4.6	3.1	2.1	1.0	4.6	3.5	2.6	2.0	6.3	3.9	2.5	1.7	1.6	7.0	4.6	3.1	2.1	1.0
SLD 27-7SV-HH	10.0	8.0	5.0	3.0	2.0	6.4	6.0	4.2	2.9	8.7	6.8	4.1	2.4	3.2	9.7	7.9	5.0	3.1	2.1
SLD 27-9SV-HH	13.0	9.0	6.0	4.0	2.0	8.3	6.8	5.1	3.8	11.3	7.6	4.9	3.2	3.2	12.7	8.3	6.0	4.1	2.1
SLD 54-11SV-HH	20.0	13.5	9.5	6.5	3.5	12.8	10.2	8.0	6.2	17.4	11.4	7.8	5.2	5.7	19.5	13.4	9.5	6.6	3.6
SLD 54-13SV-HH	23.0	16.0	11.0	7.0	4.0	14.7	12.1	9.3	6.7	20.0	13.5	9.0	5.6	6.5	22.4	15.8	11.1	7.1	4.1

Refrigerant	407B					R-410A					502					507A				
	40°F	20°F	0°F	-20°F	-40°F	40°F	20°F	0°F	-20°F	-40°F	40°F	20°F	0°F	-20°F	-40°F	40°F	20°F	0°F	-20°F	-40°F
Pressure Drop PSI	3.0	2.0	1.5	1.0	0.5	3.0	2.0	1.5	1.0	0.5	3	2	1.5	1	0.5	3	2	1.5	1	0.5
SLD 8-3V-HH	0.1	0.8	0.6	0.4	0.2	1.4	0.6	0.5	0.3	0.1	0.9	0.6	0.4	0.3	0.2	1.0	0.7	0.5	0.3	0.2
SLD 8-3SV-HH	1.1	0.8	0.7	0.5	0.3	1.5	0.7	0.5	0.4	0.2	1.0	0.7	0.5	0.4	0.2	1.1	0.8	0.6	0.4	0.2
SLD 8-4V-HH	2.1	1.5	1.0	0.7	0.4	2.9	1.2	0.8	0.5	0.3	1.8	1.2	0.9	0.6	0.3	2.1	1.4	0.9	0.6	0.3
SLD 8-4SV-HH	2.4	1.7	1.1	0.8	0.5	3.2	1.4	0.9	0.6	0.4	2.0	1.3	1.0	0.7	0.4	2.3	1.6	1.0	0.7	0.4
SLD 8-5SV-HH	3.6	2.4	1.7	1.2	0.6	4.8	2.0	1.4	0.9	0.4	3.1	2.1	1.5	1.0	0.5	3.5	2.3	1.5	1.0	0.5
SLD 8-6SV-HH	3.9	2.6	1.8	1.3	0.6	5.2	2.1	1.4	1.0	0.4	3.3	2.3	1.6	1.1	0.5	3.8	2.5	1.6	1.1	0.5
SLD 13-5V-HH	3.8	2.5	1.9	1.3	0.8	5.1	2.1	1.5	1.0	0.6	3.2	2.3	1.6	1.0	0.6	3.7	2.4	1.7	1.1	0.6
SLD 13-5SV-HH	4.6	2.8	2.4	1.4	1.0	6.2	2.3	1.9	1.1	0.7	4.0	2.5	2.0	1.0	0.6	4.5	2.7	2.1	1.2	0.8
SLD 13-6SV-HH	6.5	4.2	2.9	1.9	1.0	8.7	3.4	2.3	1.5	0.7	5.0	3.5	2.5	1.5	1.0	6.3	4.0	2.6	1.7	0.8
SLD 13-7SV-HH	6.5	4.2	2.9	1.9	1.0	8.7	3.4	2.3	1.5	0.7	5.0	3.5	2.5	1.5	1.0	6.3	4.0	2.6	1.7	0.8
SLD 13-9SV-HH	6.7	4.3	2.9	2.0	1.0	8.9	3.5	2.3	1.6	0.7	5.1	3.6	2.6	1.5	1.0	6.4	4.1	2.6	1.7	0.8
SLD 27-7SV-HH	9.3	7.5	4.8	2.9	1.9	12.4	6.1	3.8	2.2	1.5	8.0	5.0	4.0	2.5	1.5	8.9	7.2	4.3	2.5	1.6
SLD 27-9SV-HH	12.1	8.5	5.7	3.9	1.9	16.1	6.9	4.5	3.0	1.5	10.0	7.0	5.0	3.0	2.0	11.6	8.1	5.1	3.3	1.6
SLD 54-11SV-HH	18.6	12.7	9.0	6.3	3.4	24.8	10.3	7.2	4.8	2.6	15.0	10.5	7.5	5.0	3.0	17.9	12.1	8.1	5.4	2.8
SLD 54-13SV-HH	21.4	15.1	10.5	6.7	3.9	28.5	12.2	8.3	5.2	2.9	18.0	12.5	9.0	6.0	3.0	20.6	14.3	9.4	5.8	3.2

Replacement Dryer Shells and Filter Cores

Parker replacement filter cores and dryer shells are designed to provide flexibility over a widerange of applications. All models are designed for use in both the liquid *and* suction line of refrigeration or air conditioning systems. In single or multiple-core applications, cores may be loaded individually for ease of installation in tight spots. A wide range of fittings for suction-line applications and interchangeable laying-in dimensions with other manufactured models increase product versatility.

A new design of the internal assembly provides the advantage of using the Parker PFE-48BF filter element, which removes solid contaminants such as copper oxides, chips and other metal fines. The new design is also suited for using Parker dryer cores such as the Z-48 or the PCK-48HH, which provides removal of moisture, acid, wax and oil/flux paste.



Key Features and Benefits

- Solid copper full flow fittings – 5\8" to 3 1\8"
- Powder paint exterior coating surpasses 500 hour ASTM salt spray tests and resists corrosion.
- Aluminum end plates and stainless steel bolts
- For suction application: removable screen.
- U.L. listed file no. SA3441, CSA certified LR46423.
- Working pressure: 500 psi
- All welded construction

Replaceable Core Shell Dimensions

Shell	No. of Cores	Connection Size & Type	Dimensions (inches)					
			A	B	C	D	E	F
P485	1	5/8 ODF	9.14	5.52	3.18	0.63	0.63	4 3/4
P487	1	7/8 ODF	9.45	5.83	3.49	0.88	0.88	4 3/4
P489	1	1 1/8 ODF	9.45	5.83	3.49	1.00	1.00	4 3/4
P4811	1	1 3/8 ODF	9.66	6.04	3.70	1.00	1.00	4 3/4
P4813	1	1 5/8 ODF	9.65	6.03	3.69	1.00	1.00	4 3/4
P4817	1	2 1/8	10.16	6.54	3.97	1.34	1.34	4 3/4
P4821	1	2 5/8 ODF	10.34	6.22	4.16	1.50	1.50	4 3/4
P967	2	7/8 ODF	14.95	11.33	3.49	0.88	0.88	4 3/4
P969	2	1 1/8 ODF	14.95	11.33	3.49	1.00	1.00	4 3/4
P9611	2	1 3/8 ODF	15.16	11.54	3.70	1.00	1.00	4 3/4
P9613	2	1 5/8 ODF	15.15	11.53	3.69	1.00	1.00	4 3/4
P9617	2	2 1/8 ODF	15.56	11.94	3.97	1.34	1.34	4 3/4
P9621	2	2 5/8 ODF	15.75	11.63	4.16	1.50	1.50	4 3/4
P9625	2	3 1/8 ODF	15.93	10.57	4.37	1.75	1.75	4 3/4
P1449	3	1 1/8 ODF	20.51	16.89	3.49	1.00	1.00	4 3/4
P14411	3	1 3/8 ODF	20.72	17.10	3.70	1.00	1.00	4 3/4
P14413	3	1 5/8 ODF	20.71	17.09	3.69	1.00	1.00	4 3/4
P14417	3	2 1/8 ODF	21.56	17.63	3.97	1.34	1.34	4 3/4
P19211	4	1 3/8 ODF	26.28	22.66	3.70	1.00	1.00	4 3/4
P19213	4	1 5/8 ODF	26.27	22.65	3.69	1.00	1.00	4 3/4
P19217	4	2 1/8 ODF	27.12	23.12	3.97	1.34	1.34	4 3/4

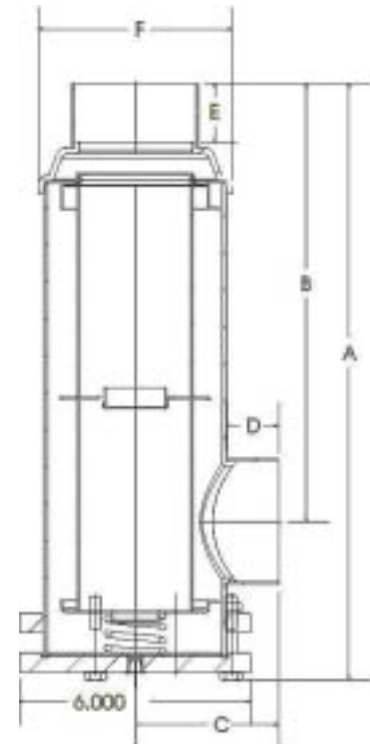

Filter Elements and Cores

Z-48 Super High Capacity Core

Most highly recommended for use with POEs. Formulated for use with the new refrigerants, blends and synthetic polyolester oils. For hi-moisture, acid, sludge and particulate removal. The Z-48 has 3 times the moisture capacity of standard cores.



PCX-48 High Capacity Gold Label Core

For use in either liquid or suction line applications, the PCX-48 offers significantly higher moisture and acid capacity than standard cores. For systems with excessive moisture concerns and polyolester oils.



PCK-48 Burnout/Clean-up Core

For use in either liquid or suction line applications, the PCK-48 is formulated for burnouts where wax is not the issue. It also provides general clean-up of acids, varnishes, sludge and moisture.



PCK-48HH Charcoal Burnout Core

Formulated with charcoal to remove wax on low temperature systems even before problems occur. The PCK-48HH can be used in either liquid or suction line applications and also removes acids, water, solids and sludge. Recommended for refrigerant reclaim/recovery units.



PCK-100 High Capacity Core

For use in either liquid or suction line applications, the PCK-100 provides the lowest pressure drop possible while retaining high filter capacity. The PCK-100 offers high water and acid capacities to assure fast system clean-up. Ideal for corrective or preventative maintenance programs.



PFE-48BF Parker Filter Element

For use in filtering out solid contaminants. Suitable for bi-directional applications, this filter features low pressure drop and filtration capabilities down to 10 microns. It is also interchangeable with other manufacturers' filters.



Replacement Filter Core Dryer Water Drop Capacity at ARI Conditions

Core Model	R-12	R-22	R-134a	R-401A/B	R-401C	R-402A	R-402B
	(15 ppm) 75°F/125°F	(60 ppm) 75°F/125°F	(150 ppm) 75°F/125°F	(50 ppm) 75°F/125°F	(50 ppm) 75°F/125°F	(50 ppm) 75°F/125°F	(50 ppm) 75°F/125°F
PCX-48	770/607	697/524	762/591	746/551	725/544	756/558	756/558
PCK-48HH	524/374	474/322	518/363	507/339	493/335	512/343	512/343
PCK-48	607/447	549/386	600/435	587/406	571/401	596/411	596/411
Z-48	1833/1660	1659/1433	1814/1614	1775/1505	1726/1487	1799/1524	1799/1524
PCK-100	1572/1235	1422/1066	1556/1201	1522/1120	1481/1107	1543/1134	1543/1134

Core Model	R-404A	R-407A	R-407B	R-407C	R-502	R-507A
	(50 ppm) 75°F/125°F	(50 ppm) 75°F/125°F	(50 ppm) 75°F/125°F	(50 ppm) 75°F/125°F	(50 ppm) 75°F/125°F	(50 ppm) 75°F/125°F
PCX-48	758/581	501/369	501/369	534/392	709/544	766/584
PCK-48HH	515/357	341/227	341/227	363/241	482/335	521/359
PCK-48	597/428	395/272	395/272	420/288	559/401	604/430
Z-48	1804/1587	1193/1008	1193/1008	1270/1070	1688/1487	1823/1596
PCK-100	1547/1181	1023/750	1023/750	1090/796	1447/1107	1564/1188

Selection Recommendations for System Sizing

Shell	No. of Cores	Connection Size and Type	Air Conditioning								
			Refrigeration Low Temp. & Commercial Installations			Field Replacement & Field Installations			OEM / Self Contained Equipment		
			R-134a	R-22	R404A/R-507A	R-134a	R-22	R404A/R-507A	R-134a	R-22	R404A/R-507A
P485	1	5/8 ODF	8	10	8	8	10	8	12	15	10
P487	1	7/8 ODF	11	15	10	11	14	10	15	20	13
P489	1	1 1/8 ODF	11	15	10	13	17	10	20	25	15
P4811	1	1 3/8 ODF	13	20	13	13	20	13	20	25	15
P4813	1	1 5/8 ODF	15	20	15	15	20	15	22	27	20
P4817	1	2 1/8 ODF	20	25	20	20	25	20	25	30	22
P4821	1	2 5/8 ODF	20	25	20	20	25	20	25	30	22
P967	2	7/8 ODF	20	25	15	20	25	15	27	35	20
P969	2	1 1/8 ODF	25	33	20	25	33	20	33	40	25
P9611	2	1 3/8 ODF	30	35	25	30	35	25	35	45	30
P9613	2	1 5/8 ODF	35	40	30	35	40	30	40	50	35
P9617	2	2 1/8 ODF	40	45	35	40	45	35	45	55	40
P9621	2	2 5/8 ODF	40	45	35	40	45	35	45	55	40
P9625	2	3 1/8 ODF	45	50	40	45	50	40	50	60	45
P1449	3	1 1/8 ODF	30	40	30	30	40	30	40	55	35
P14411	3	1 3/8 ODF	40	50	35	40	50	35	50	65	40
P14413	3	1 5/8 ODF	50	50	40	45	55	40	55	70	45
P14417	3	2 1/8 ODF	60	50	45	50	60	45	60	80	50
P19211	4	1 3/8 ODF	50	70	45	50	70	45	60	80	50
P19213	4	1 5/8 ODF	60	80	55	60	80	55	77	100	60
P19217	4	2 1/8 ODF	65	85	60	65	85	60	80	105	65

PCK-100 Core Installation Recommendations - Nominal Tons

No. of Cores	Filter Area	Refrigeration Comm. and Low Temperature				Air Conditioning OEMs, Self-contained, Split & Field Replacement		
		R-134a R-401a	R-22 R-407a	R-407b R-404a R-507	R-407c R-410a	R-134a R-410a R-407b	R-22 R-407c R-410a	R-407a R-502 R-507A
3	294	75	100	60	65	100	125	80
3	294	80	110	65	70	105	130	85
4	392	110	130	100	125	130	150	125
4	392	115	135	105	130	135	165	125

Filters and Pre-Filters

Parker provides a large selection of components for recovery, recycle and reclaim machines, protecting them from the many types of contaminants that are encountered during the servicing of systems.

PF Series

The PF 052 & PF 052MF are designed to provide a filtration level of 15 microns. When installed on the inlet of your machine it can prevent costly damage by filtering solid contaminants out of the refrigerant before it enters your machine. The Parker pre-filter is for temporary use only and should be changed after servicing a maximum of six to eight systems. Change out may be needed sooner depending on actual system conditions. Various fitting combinations are available.



Key Features and Benefits

- Female outlet fitting allows direct mounting to the machine.
- Extended female end fitting provides valve handle clearance.
- Male-to-male fittings allow connection to or between hoses.
- Enlarged depth filtering area.
- UL listed / CSA certified.

Model	Inlet	Outlet
PF 052	1/4" SAE male flare	1/4" SAE male flare
PF 052MF	1/4" SAE male flare	1/4" SAE female flare

SPD Series

The SPD series is an enlarged version of the PF Series with drying capabilities. This Super Pre-Filter-Dryer should be installed at the inlet of the machine and used where there are concentrations of contaminants in the refrigerant. Moisture capacity of this unit size exceeds anything else currently available in the market. The Super SPD series is the ideal solution when transferring large amounts of refrigerant for reclaim or recycle.



Key Features and Benefits

- Super high capacity for acid and moisture removal.
- Removes 504 drops of moisture vs. industry standard of 150 drops.
- Available with either 1/4" SAE or 3/8" SAE flare connections.
- Compatible with all HCFC, CFC and other refrigerants and blends.

Model	Inlet	Outlet
SPD-162	1/4" SAE male flare	1/4" SAE male flare
SPD-162MF	1/4" SAE male flare	1/4" SAE female flare
SPD-163	3/8" SAE male flare	3/8" SAE male flare

LP Gas Filter

Additives to LP gas can cause scaling and flaking of copper and aluminum tubing over a period of time. The Parker LP Gas Filter effectively removes these contaminants

(For LP Gas Filter, consult factory for inlet/outlet data and part numbers).

Key Features and Benefits

- Special paint meets U.L. requirements for gas appliances.

PRD-3 Series

Specifically designed for OEM recovery units that require 3/8" flare connections and a larger cross sectional filter area. The PRD-3 filter dryer meets or exceeds OEM specifications providing both value and efficiency.

Key Features and Benefits

- High acid and high moisture capacity.
- Enlarged filtration area.
- 3/8" SAE male flare fittings on both ends.
- Drop in replacement for ASD-28F3 or KH45LD010
- Compatible with all HCFC, CFC and other refrigerant blends.



Model	Inlet	Outlet
PRD-3	3/8" SAE male flare	3/8" SAE male flare

Oil Vapor Dryer Separator

The Parker Vapor Dryer Separator (VDS Series) removes contaminated oil from a system in addition to solids, acid and moisture. A 1/4" SAE oil drain access fitting is located on the bottom to provide a continuous means of measuring the amount of oil removed from a system, thereby indicating the amount needed to be replaced. The VDS holds up to four ounces of oil and is reusable for up to 50 pounds of refrigerant, depending upon contamination levels. For rigid or secure mounting, a side bracket is welded to the body. The VDS can also be hung from a manifold gauge set with the wire strap provided. A model is available with coalescing element for improved oil separation.

Key Features and Benefits

- Oil removal drain fitting.
- Acid and moisture removal.
- 3/8" SAE male flare fittings.
- Inlet access valve fitting.
- Mounting bracket.

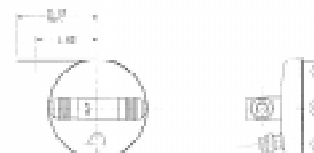
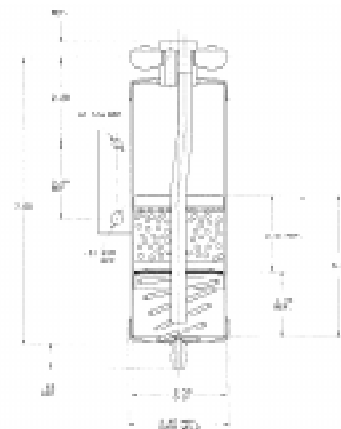

POS-321 Oil Separator

The Parker oil separator removes oil from system refrigerant by means of a highly efficient coalescing filter. The filter is 98.5% efficient, filtering oil and particles down to 1/10 of a micron while leaving a trace amount of oil necessary for adequate system lubrication. The separator is ideal for recovery and reclaim operations.

Key Features and Benefits

- 3.6 ounces/108 ml capacity
- standard 1/8" npt connection size
- 1/4" or 3/8" flare or sweat connections optional
- for use with all CFC, HCFC and HFC refrigerants
- design pressure of 500 psig / 3550 kPa / 35.5 bar
- U.L. listed SA5915



Oil Reservoirs

Parker oil reservoirs are holding vessels for stand-by oil necessary for the operation of a system.

Key Features and Benefits

- Two or three sight glass ports for oil level monitoring.
- 3/8" flare valve on the top and bottom shipped separately to be adjusted per customer requirements. Allows isolation of the reservoir for addition or removal of oil from the tank.
- Vent port for connection to the suction line to prevent pressure build up in the reservoir.
- Available with mounting studs and brackets.
- Other sizes available: 1/4 and 1/2 tons.



Model No.	Parker Part No.	Total Capacity in Gallons	A Capacity Gallons	B Capacity Gallons	Length Inches
POR-2	089351-00	2	3/4	3/4	18
POR-3	089379-00	3	3/4	3/4	23
POR-4	089350-00	3	3/4	1 1/2	36

A capacity is the capacity to the first sight glass.

B capacity is the capacity between the glasses.

PS-033 Oil Strainer

Parker oil strainers removes contaminant from the oil line by means of a 200 mesh filter screen.

Key Features and Benefits

- Filtration area = 7.0 square inches.
- 3/8" SAE steel male flare connections.
- U.L. listed.
- Design pressure of 500 psig (3550 kPa).



Copper Strainers/Strainer Distributors

Strainers are low cost filtration devices designed to protect refrigeration components, including valves, compressors and capillary tubes, from system contaminants.



Key Features and Benefits

- Copper construction to resist corrosion.
- 500 psig design pressure.
- Available in a variety of inlet and outlet sizes.
- UL recognized (File SA-8570) and CSA certified (LR-87950).

Proper selection of strainers is based on two parameters:

1. Maximum operating pressure
2. Contaminants present in the system.

Maximum Operating Pressure

Information regarding operating pressure is required to adequately size the wall thickness of the strainer to attain the ultimate burst pressure. In accordance with Underwriters Laboratories (UL) and Canadian Standards Association (CSA), the burst pressure for Parker strainers is rated as five times the design working pressure of the system. Listed in the catalog as design working pressure, this value can be correlated to tube diameter and wall thickness in order to meet specific UL specifications.

Contaminants

To determine the type and area of the screen, information about contaminants is needed. The size, type and cleanliness of the refrigeration system and its components, as well as the control of the assembly process, all determine the amount and size of the contaminates

to be trapped by the strainer. The most common size of screen is 150 x 140 mesh which is used to protect capillary tubes. An extra large screen area should be selected if the strainer is expected to trap large amounts of foreign material. The large screen area will ensure there is enough area for passage of fluid without causing pressure drop.

Recommended Screen Area

Screen Area Sq. In.	Low Temp.	Med. Temp.	Low Temp. R-22	Air Cond. R-22
	R-12 & R-134a 0° F or below	R-12 & R-134a 0° F or above		
0.8	1/8 hp	1/4 hp	1/8 hp	1/3 hp
1.8	1/4 hp	1/3 hp	1/3 hp	1/2 hp
2.2	1/3 hp	1/2 hp	1/2 hp	3/4 hp
2.3	1/2 hp	3/4 hp	3/4 hp	1 hp
5.2	1 1/2 hp	2 hp	1 1/2 hp	3 hp
6	2 hp	3 hp	2 hp	5 hp

Strainer Screen Dimensions

Mesh	Particle Size			Micron Size	% Open Area
	Diameter of Wire	Maximum Diameter	Screen Material		
100 x 90	0.0045	0.0055	s.s.	140	30%
120 x 108	0.0036	0.0046	brass	117	30%
150 x 140	0.0026	0.0041	s.s.	104	37%

Strainer Dimensions

Model No.	Overall Length (In.)	Area Sq. Inches	Inlet I.D.	Outlet I.D.	Screen
PS-2S	2.75	1.00	1/4	1/4	120 mesh brass
PS-3S	2.75	1.00	3/8	3/8	120 mesh brass
PS-4S	3.00	1.00	1/2	1/2	100 mesh stainless steel
PS-5S	5.13	8.37	5/8	5/8	100 mesh stainless steel
PS-7S	5.13	8.37	7/8	7/8	100 mesh stainless steel
PS-9S	5.44	10.62	1 1/8	1 1/8	100 mesh stainless steel
PS-11S	5.44	10.62	1 3/8	1 3/8	100 mesh stainless steel
PS-13S	6.00	10.62	1 5/8	1 5/8	40 mesh stainless steel

*Models in this chart are Standard Aftermarket Products.

5/8" O.D. Copper Strainers - Standard Products

Part No.	Design Working Pressure PSIG	Filtration Capacity Microns	Screen Area Sq. In.	(B) Inlet Inch ID	(C) Outlet Inches ID	Overall Length In. (A)
054139-00	500	140	0.75	1/4	.147-.152	2.25

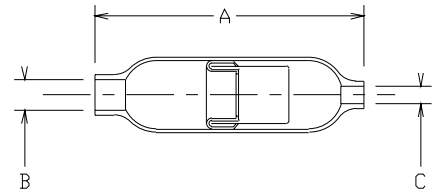

3/4" O.D. Copper Strainers

Part No.	Design Working Pressure PSIG	Filtration Capacity Microns	Screen Area Sq. In.	(B) Inlet Inch ID	(C) Outlet Inches ID	Overall Length In. (A)
054816-03	500	117	0.88	1/4	1/4	2.75
054816-06	500	117	0.88	3/8	5/16	2.75
054816-01	500	117	0.88	3/8	3/8 OD	2.75
054816-02	500	117	0.88	3/8	3/8	2.75
054816-10	500	117	0.88	1/2	1/2 OD	2.75
056822-00	500	140	0.88	1/2	1/2	3
051163-01	500	140	4.55	3/8	3/8	5.75

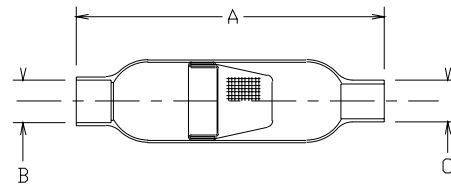

1" O.D. Copper Strainers

<i>STANDARD PRODUCT</i>						
Part No.	Design Working Pressure PSIG	Filtration Capacity Microns	Screen Area Sq. In.	(B) Inlet Inch ID	(C) Outlet Inches ID	Overall Length In. (A)
057073-01	500	140	1.96	3/8	8 @ 1/8	4.25
<i>MODIFIED STANDARD</i>						
441601	360-540	104	1.96	see chart below		3.8-4.3

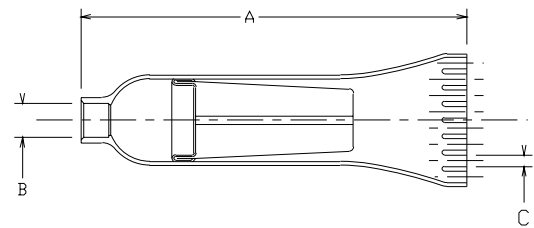

Outlet Options

Outlet	No. of Holes	Outlet	No. of Holes
0.081	1	0.125	1, 2, 3, 4, 5, 6, 8
0.087	1	3/16	1
0.093	1	1/4	1
0.099	1	5/16	1
0.106	1, 2, 3, 4, 5, 6, 8	3/8	1
0.112	1	1/2	1

Inlet Options

Inlet	No. of Holes
3/16	1
1/4	1, 2
5/16	1, 2
3/8	1
1/2	1
5/8	1

All 1" O.D. strainers are Underwriters Laboratories recognized file SA-8570, guide card SMGT-2 and Canadian Standards Association certified file No. LR-87950 Model 1025.

1 3/16" O.D. Copper Strainers

<i>STANDARD PRODUCT</i>						
Part No.	Design Working Pressure PSIG	Filtration Capacity Microns	Screen Area Sq. In.	(B) Inlet Inch ID	(C) Outlet Inches ID	Overall Length In. (A)
058307-00	500	140	8.37	1/2	1/2	5.13
<i>MODIFIED STANDARD</i>						
441901	500	104	2.32	see chart below		5.8-6.5

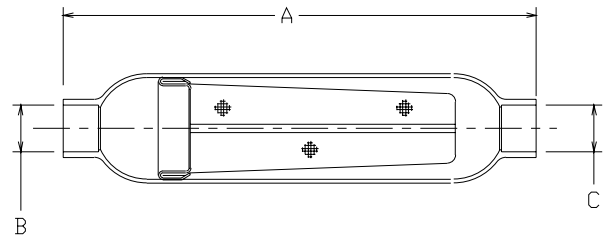

Outlet Options

Outlet	No. of Holes	Outlet	No. of Holes
0.099	1, 2, 3, 4, 5, 6	1/4	1
0.106	1, 2, 4	5/16	1
0.112	1, 3, 4, 6	3/8	1, 2
0.125	1, 2	1/2	1

Inlet Options

Inlet	No. of Holes
1/4	1
5/16	1, 2
3/8	1, 2
1/2	1
5/8	1

All 1 3/16" O.D. strainers are Underwriters Laboratories recognized file SA-8570, guide card SMGT-2 and Canadian Standards Association certified file No. LR-87950 Model 319.

1 5/8" O.D. Copper Strainers

Part No.	Design Working Pressure PSIG	Filtration Capacity Microns	Screen Area Sq. In.	(B) Inlet Inches ID	(C) Outlet Inches ID	Overall Length In. (A)
053830-01	500	140	10.62	1/4	1/4	5.13
054745-01	500	140	10.62	5/8	.617-.622 OD	5.44

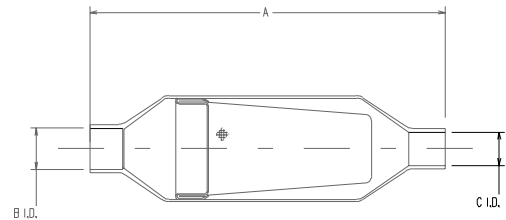

All 1 5/8" O.D. strainers are Underwriters Laboratories recognized file SA-8570, guide card SMGT-2 and Canadian Standards Association certified file No. LR-87950 Model 1638.

Introduction to Accumulators

The prime function of a suction line accumulator in a heat pump or refrigeration system is to catch and hold any unused portion of the system charge. It must also prevent liquid slugging of the compressor and excessive refrigerant dilution of the compressor oil.

The accumulator must return refrigerant and oil to the compressor at a sufficient rate to maintain both system operating efficiency and proper crankcase oil level. To make sure these tasks are accomplished, system designers must consider the following items:

- The accumulator must have sufficient internal volume.
- A properly sized and protected oil return orifice is required to ensure positive oil (and refrigerant) return to the compressor.
- The pressure drop across the accumulator should be as low as possible for given inlet and outlet fitting sizes.

Oil return at minimum flow rate is controlled by the outlet U-tube size. Refrigerant and oil will be returned to the compressor by pressure drop across the orifice metering area and the liquid head above the orifice. Other design requirements include:

- Safe working and burst pressures.
- Agency approvals.
- Salt spray, moisture, and corrosion resistance.

Figure 1 shows a typical accumulator with an inlet deflector. The shape of the deflector directs the inlet flow in a slightly downward tangential direction.

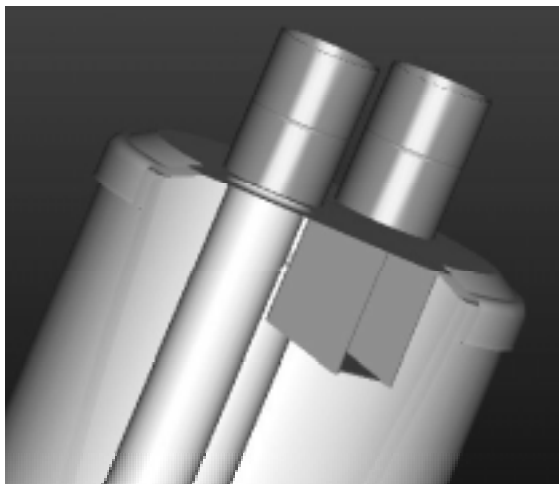

FIGURE 1 - Typical accumulator with inlet deflector baffle.

The inlet to the U tube is located behind the inlet deflector to prevent liquid carry-over and is bell-shaped to reduce the sudden contraction loss of the high-velocity gas. The U-tube diameter is selected to minimize pressure drop at high flow rates yet provide adequate oil return at low flow rates.

A 50 x 60 mesh screen is installed to protect the small diameter oil return orifice.

An anti-siphon hole, provided near the outlet of the U tube, prevents liquid from siphoning into the outlet tubing and compressor during an off cycle.

A fusible alloy plug is generally a U.L. requirement. It is a safety device to protect against excessive pressures in the event of a fire.

Accumulator Fine Tuning

Accumulator selection can be fine tuned for best performance. This involves the sizing of the accumulator, and the sizing of the orifice. The controlling factor for both is the type of metering device used on the system, either a fixed orifice or a thermostatic expansion valve.

In systems using a fixed orifice in the heating mode, the accumulator holding capacity should be about 70% of the system charge. This should provide adequate holding capacity during operation with blocked or fouled heat exchanger coils. The resulting high discharge / low suction pressure condition will push much of the system charge into the accumulator. The oil return orifice size should be small to prevent excess liquid refrigerant being returned to the compressor. This would excessively reduce the compressor discharge temperature, lowering heating performance. Parker recommends a 0.040 inch diameter orifice as a good starting point for these systems.

In systems using an expansion valve, the accumulator holding capacity should be about 50% of the system charge. At startup and after defrost, the bulb of the expansion valve is warm. This causes flooding of the evaporator and brings the accumulator into play until the valve regains control. The accumulator must also deal with off cycle refrigerant migration. At shut down, the accumulator is the coldest component in the system. This results in migration of liquid refrigerant to the lower temperature accumulator. This type of system needs to get the refrigerant returned to circulation more quickly than the fixed orifice system. Parker

recommends a 0.055 inch diameter orifice to allow quick return of liquid refrigerant. The recommended sizes of the orifices can be further tested for optimum results. Parker has the ability to provide orifices in sizes smaller and larger to satisfy the characteristics required by the customer.

New Refrigerants

The introduction of new refrigerants and oils has created new problems in the design of all system components and suction accumulators are no exception. As mentioned earlier, the accumulator is the coldest component in the system. The new refrigerants and the oils they are used with may not be fully miscible in the temperature range the accumulator normally operates. The oil and refrigerant can separate into oil rich and refrigerant rich layers in the accumulator, with the refrigerant rich layer at the bottom. The oil return orifice is located in the now refrigerant rich layer.

Parker's solution to this problem is to provide active mixing of the layers in the accumulator. This is accomplished by the shape and positions of the inlet deflector and outlet U-tube. The inlet flow stream is directed tangentially into the liquid layers in the bottom of the accumulator. The resulting circulation of the liquid past the off center U-tube forces a mixing of the oil and refrigerant layers.

Field Replacement

Parker recommends that the accumulator should be changed when a compressor is replaced. The old accumulator may contain contaminants from the problem that caused the compressor failure. There may also be considerable oil remaining from the first compressor if a gradual loss of charge caused the failure. This amount coupled with the oil in the replacement compressor may create an oil over charge condition.

Steel Suction Line Accumulators

"U" Tube Style Accumulators

The Parker "U" tube accumulator design is a result of extensive laboratory testing plus detailed investigation of the various accumulators currently available. It takes into account all of the requirements essential for heat pump applications, including safe holding volume (relative to the system's total charge), protected flow control for positive refrigerant and oil return, and minimum pressure drop across the accumulator.

Parker offers standard accumulator models designed for application on heat pump and refrigeration systems from 1/4 through 12 tons. Liquid refrigerant holding requirements of suction accumulator may vary by application. Because of the diversity in heat pump systems, accumulator capacity selection should be determined by actual testing. Consult Parker for assistance if required.

Key Features & Benefits

- Solid copper connections
- "U" tube design for maximum flow of refrigerant and minimum oil entrapment.
- Inlet flow deflector guides refrigerant toward wall for smooth tangential flow and gradual expansion.
- "U" tube entrance is positioned behind the inlet flow deflector to prevent unwanted liquid refrigerant from entering and damaging compressor.
- Metering orifice matched to system capacity assures optimum liquid refrigerant and oil flow back to compressor.
- Protective screen and orifice assembly on "U" tube protects against foreign particles and contaminants affecting metering function.
- Fittings and "U" tube are matched to accumulator holding capacity and total system charge for minimum pressure drop and maximum refrigerant flow.
- U.L. listed for 355 psig design pressure. File No. SA5172.
- Powder paint exterior coating surpasses 500 hour ASTM salt spray tests.
- Integral 430° F Fuse Plugs (U.L. File No. SA5441).



also available:

Heat Exchanger Accumulator

- Can be made in all models of Parker's standard accumulators.
- Copper heat exchange coil for superior heat exchange.
- Liquid line connections available in 3/8" I.D..

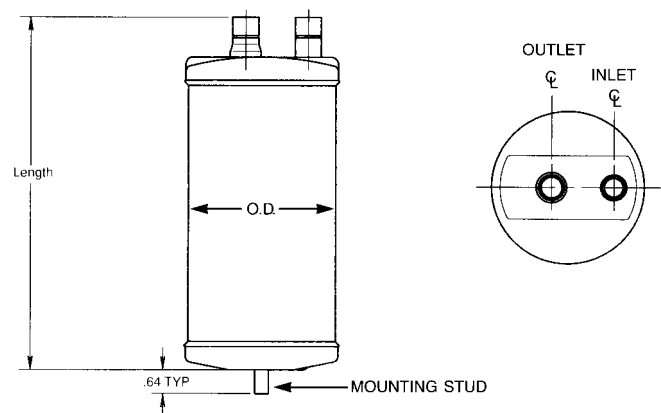

Steel Suction Line Accumulator Dimensions and Flow Data

Model No.	Solder Fitting Size	Dimensions (inches)		Capacity ¹ (oz.)	Evap. Temp °F	Recommended capacity in tons of refrigeration													
		Length	O.D.			22 & 404A		134a		401A		402A		407C		410A		502 & 507A	
						Tons @ 1 psi	Min. Tons	Tons @ 1 psi	Min. Tons	Tons @ 1 psi	Min. Tons	Tons @ 1 psi	Min. Tons	Tons @ 1 psi	Min. Tons	Tons @ 1 psi	Min. Tons	Tons @ 1 psi	Min. Tons
PA3060-10-4	1/2"	10.35	3	35	40	2.00	0.35	1.67	0.30	1.42	0.25	1.97	1.01	1.97	0.46	1.93	1.44	1.48	0.27
PA3060-10-5	5/8"	10.35	3	35	0	1.54	0.25	0.98	0.16	1.06	0.18	1.53	0.41	1.53	0.18	1.50	0.65	1.10	0.2
					-20	1.33	0.21	0.69	0.11	0.90	0.15	1.32	0.25	1.32	0.11	1.30	0.42	0.93	0.16
PA3060-15-5	5/8"	15.05	3	55	40	2.10	0.35	1.75	0.30	1.49	0.25	2.07	1.01	2.07	0.46	2.02	1.44	1.55	0.27
					0	1.62	0.25	1.03	0.16	1.11	0.18	1.61	0.41	1.60	0.18	1.57	0.65	1.16	0.2
					-20	1.40	0.21	0.73	0.11	0.95	0.15	1.39	0.25	1.39	0.11	1.36	0.42	0.98	0.16
PA3060-15-6	3/4"	15.05	3	54	40	2.30	0.35	1.92	0.30	1.63	0.25	2.27	1.01	2.27	0.46	2.22	1.44	1.70	0.27
					0	1.77	0.25	1.12	0.16	1.22	0.18	1.76	0.41	1.75	0.18	1.72	0.65	1.27	0.2
					-20	1.53	0.21	0.8	0.11	1.04	0.15	1.52	0.25	1.52	0.11	1.49	0.42	1.07	0.16
PA4065-9-5C	5/8"	9.62	4	60	40	2.96	0.35	2.47	0.30	2.10	0.25	2.92	1.01	2.92	0.46	2.85	1.44	2.19	0.27
					0	2.28	0.25	1.44	0.16	1.57	0.18	2.27	0.41	2.26	0.18	2.21	0.65	1.63	0.2
					-20	1.98	0.21	1.03	0.11	1.34	0.15	1.97	0.25	1.96	0.11	1.93	0.42	1.39	0.16
PA4065-9-6C	3/4"	9 5/8"	4	58	40	3.00	0.35	2.53	0.30	2.10	0.25	2.96	1.01	2.96	0.46	2.89	1.44	2.20	0.28
					0	2.30	0.25	1.48	0.16	1.60	0.18	2.29	0.41	2.28	0.18	2.23	0.65	1.70	0.2
					-20	2.00	0.21	1.05	0.11	1.40	0.15	1.99	0.25	1.98	0.11	1.95	0.42	1.40	0.16
PA5083-9-6C	3/4"	9.62	5	89	40	3.82	0.57	3.19	0.49	2.71	0.41	3.76	1.51	3.77	0.69	3.68	2.16	2.82	0.46
					0	2.95	0.41	1.86	0.27	2.03	0.30	2.94	0.61	2.92	0.27	2.86	0.98	2.10	0.33
					-20	2.55	0.35	1.32	0.18	1.73	0.24	2.53	0.37	2.53	0.16	2.48	0.63	1.79	0.27
PA5083-9-7C	7/8"	9.63	5	86	40	3.90	0.57	3.21	0.49	2.70	0.41	3.84	1.51	3.85	0.69	3.76	2.16	2.80	0.46
					0	3.00	0.41	1.88	0.27	2.00	0.30	2.98	0.61	2.97	0.27	2.91	0.98	2.10	0.33
					-20	2.60	0.35	1.33	0.18	1.70	0.24	2.58	0.37	2.58	0.16	2.53	0.63	1.80	0.27
PA5083-12-7C	7/8"	12.88	5	125	40	5.41	0.88	4.51	0.75	3.83	0.64	5.33	2.12	5.34	0.96	5.21	3.03	4.00	0.7
					0	4.17	0.64	2.64	0.42	2.87	0.45	4.15	0.86	4.13	0.38	4.05	1.37	2.98	0.51
					-20	3.61	0.54	1.87	0.28	2.45	0.37	3.59	0.52	3.58	0.22	3.52	0.88	2.53	0.41
PA5083-11-7C	7/8"	11.33	5	108	40	4.38	0.57	3.21	0.43	3.10	0.41	4.32	1.51	4.32	0.69	4.22	2.16	3.23	0.46
					0	3.37	0.41	1.88	0.24	2.32	0.30	3.35	0.61	3.34	0.27	3.27	0.98	2.41	0.33
					-20	2.92	0.35	1.33	0.16	1.98	0.24	2.90	0.57	2.89	0.16	2.84	0.63	2.04	0.27
PA5083-11-6C	3/4"	11.33	5	111	40	3.85	0.57	3.21	0.49	2.72	0.41	3.79	1.51	3.80	0.69	3.71	2.16	2.84	0.46
					0	2.97	0.41	1.88	0.27	2.04	0.30	2.96	0.61	2.94	0.27	2.88	0.98	2.12	0.33
					-20	2.56	0.35	1.33	0.18	1.74	0.24	2.54	0.57	2.54	0.16	2.49	0.63	1.80	0.27
PA5083-15-7C	7/8"	15.34	5	156	40	6.20	0.88	5.17	0.75	4.39	0.64	6.11	2.12	6.12	0.96	5.97	3.03	4.58	0.7
					0	4.78	0.64	3.03	0.42	3.29	0.45	4.76	0.86	4.73	0.38	4.64	1.37	3.41	0.51
					-20	4.13	0.54	2.15	0.28	2.80	0.37	4.10	0.52	4.09	0.22	4.02	0.88	2.90	0.41
PA5083-17-7C	7/8"	17.25	5	179	40	6.20	0.88	5.17	0.75	4.39	0.64	6.11	2.12	6.12	0.96	5.97	3.03	4.58	0.7
					0	4.78	0.64	3.03	0.42	3.27	0.45	4.76	0.86	4.73	0.38	4.64	1.37	3.41	0.51
					-20	4.13	0.54	2.15	0.28	2.80	0.37	4.10	0.52	4.09	0.22	4.02	0.88	2.90	0.41
PA6125-15-9C	1 1/8"	15.00	6	211	40	9.00	3.00	8.83	1.97	6.10	1.90	8.87	3.45	8.88	1.57	8.67	4.93	7.30	3
					0	5.60	2.00	5.62	0.82	3.70	1.20	5.57	1.40	5.55	0.62	5.44	2.23	4.50	2
					-20	4.30	0.80	4.31	0.50	2.80	0.05	4.27	0.85	4.26	0.36	4.19	1.43	3.40	0.8
PA6125-15-11C	1 3/8"	15.25	6	214	40	12.00	3.00	12.05	1.97	6.20	1.90	11.82	3.45	11.85	1.57	11.56	4.93	9.80	3
					0	7.50	2.00	7.52	0.82	5.00	1.20	7.46	1.40	7.43	0.62	7.28	2.23	6.00	2
					-20	5.80	0.80	5.82	0.50	3.60	0.05	5.76	0.85	5.75	0.36	5.65	1.43	4.60	0.8
PA6125-18-9C	1 1/8"	18.00	6	264	40	8.80	3.00	8.84	1.97	6.00	1.90	8.67	3.45	8.69	1.57	8.48	4.93	7.20	3
					0	5.50	2.00	5.52	0.82	3.70	1.20	5.47	1.4	5.45	0.62	5.34	2.23	4.40	2
					-20	4.30	0.80	4.31	0.50	2.80	0.05	4.27	0.85	4.26	0.36	4.19	1.43	3.40	0.8
PA6125-18-11C	1 3/8"	18.00	6	267	40	11.00	3.00	11.05	1.97	7.50	1.90	10.84	3.45	10.86	1.57	10.59	4.93	9.10	3
					0	7.00	2.00	7.02	0.82	4.60	1.20	6.96	1.4	6.93	0.62	6.8	2.23	5.50	2
					-20	5.40	0.80	5.42	0.50	3.50	0.05	5.37	0.85	5.35	0.36	5.26	1.43	4.20	0.8
PA6125-20-11C	1 3/8"	20.25	6	302	40	11.00	3.00	11.05	1.97	7.50	1.90	10.84	3.45	10.86	1.57	10.59	4.93	9.10	3
					0	7.00	2.00	7.02	0.82	4.60	1.20	6.96	1.4	6.93	0.62	6.8	2.23	5.50	2
					-20	5.40	0.80	5.42	0.50	3.50	0.05	5.37	0.85	5.35	0.36	5.26	1.43	4.20	0.8

¹ Holding capacity of R-22 at 40° F. Divide by .7 to obtain recommended maximum system charge on fixed orifice systems. Consult Parker for availability.



Stand Pipe Style Accumulators

Key Features and Benefits

- Available in 2 1/2", 3" and 4" diameters.
- Copper and copper plated steel fittings
- Standard fitting sizes: 3/4" and 7/8".
Other sizes available upon request.
- Dual, screened orifice design. Various orifice sizes available.
- U.L. listed file no. SA5172, CSA certified.

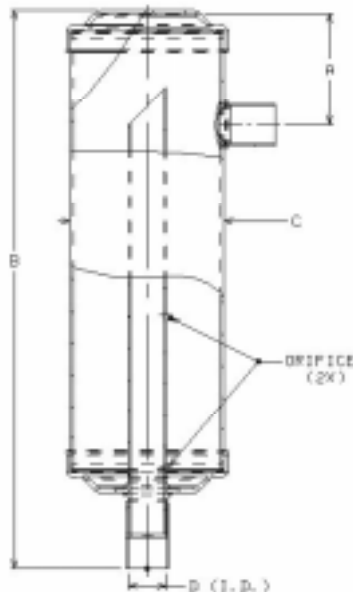

Stand Pipe Style Accumulator Dimensions

Part No.	Model No.	"A"	"B"	"C"	"D" I.D.		Orifice (2x 's)	Effective Volume
					Inlet	Outlet		
070332-00	P3060-11-6C	2.25	11.00	3.00	3/4	3/4	0.060 ty p.	41.5 in ³
070333-00	P3060-13-7C	2.25	13.00	3.00	7/8	7/8	0.060 ty p.	50.0 in ³
070342-00	P3060-13-7C	2.25	13.00	3.00	7/8	7/8	0.035 ty p.	50.0 in ³

Inlet fitting/connection available on top. Contact Parker.

Copper Accumulators

Copper accumulators are used extensively in low temperature refrigeration systems, heat pump applications, and in some residential air conditioning systems. Copper accumulators can be designed with a standpipe with an orifice to meter liquid oil and refrigerant return to the compressor or without. If the accumulator is used on a system utilizing a rotary compressor, the accumulator should include a standpipe with an orifice and a full diameter filter screen.

Parker copper accumulators come in diameters ranging from 1-1/8" to 2-1/4". The size and design of a copper accumulator is based on several factors:

- Compressor type and design.
- System charge or volume.
- System metering device.
- System operating pressure.

The design of a copper accumulator is different for every compressor application. Parker Engineering can offer assistance with customer specific design requirements. Parker copper accumulators are U.L. and CSA recognized.

1-1/8" Copper Accumulator

Part No.	Design Working Pressure PSIG	Standard Nominal Sizes (Inches)		Overall Length Inches (C)	Internal Volume (Cu. In.)
		Inlet (A)	Outlet (B)		
032185-00	500	3/8	1/4	8.25	1.97

1-3/16" Copper Accumulator

Part No.	Design Working Pressure PSIG	Standard Nominal Sizes (Inches)		Overall Length Inches (C)	Internal Volume (Cu. In.)
		Inlet (A)	Outlet (B)		
056268-00	400	3/8	3/8	5	4.41
051639-03	400	3/8	3/8	6.5	5.88
056039-01	400	3/8	5/16	6.5	5.88
056039-02	400	5/16	5/16	6.5	5.88

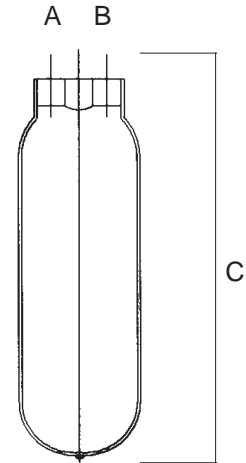

1-3/8" Copper Accumulator

Part No.	Design Working Pressure PSIG	Standard Nominal Sizes (Inches)		Overall Length Inches (C)	Internal Volume (Cu. In.)
		Inlet (A)	Outlet (B)		
057375-00	300	3/8	3/8	7.06	2.77
056380-01	300	3/8	3/8	6	6.86

1-5/8" Copper Accumulator

Part No.	Design Working Pressure PSIG	Standard Nominal Sizes (Inches)		Overall Length Inches (C)	Internal Volume (Cu. In.)
		Inlet (A)	Outlet (B)		
056238-01	400	5/16	1/4	4	6.54
056689-02	400	3/8	3/8	4	6.54
057337-00	400	1/2	1/2	5	8.40
057302-00	400	5/16	5/16	5.13	8.65
057203-00	400	1/2	5/8	6	10.27
057995-00	500	3/8	3/8	5.5	2.61
056326-02	400	1/4	1/4	7	12.14
056472-01	400	3/8	3/8	8	14.00
056463-01	400	1/2	1/2	10	17.74
056463-02	400	3/8	3/8	10	17.74



2-1/4" Copper Accumulator

Parker Part No.	Design Working Pressure PSIG	Standard Nominal Sizes (Inches)		Overall Length Inches (C)	Internal Volume (Cu. In.)
		Inlet (A)	Outlet (B)		
032237-00	325	5/8	5/8	7.81	7.41

Copper Tube Accumulators

1-1/8" Copper Stand Pipe Accumulator

Part No.	Design Working Pressure PSIG	Standard Nominal Sizes (Inches)		Overall Length Inches (C)	Internal Volume (Cu. In.)
		Inlet (A)	Outlet (B)		
032014-00	325	3/8	0.477	6.44	2.48
071440-00	325	1/2	0.589	7.25	2.14

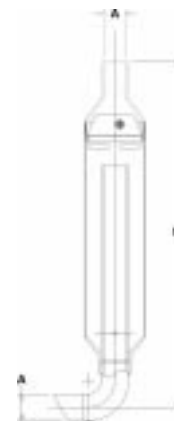

1-7/8" Copper Stand Pipe Accumulator

Part No.	Design Working Pressure PSIG	Standard Nominal Sizes (Inches)		Overall Length Inches (C)	Internal Volume (Cu. In.)
		Inlet (A)	Outlet (B)		
071442-00	325	3/8	3/8	10.2	14.98

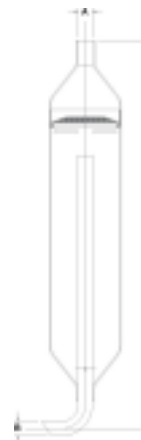

2-1/4" Copper Stand Pipe Accumulator

Part No.	Design Working Pressure PSIG	Standard Nominal Sizes (Inches)		Overall Length Inches (C)	Internal Volume (Cu. In.)
		Inlet (A)	Outlet (B)		
032236-00	325	1/2	0.616	8.19	14.87

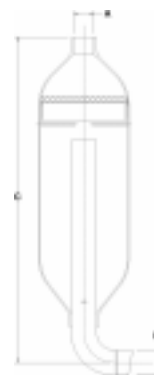

Steel Receivers

Key Features and Benefits

- Designed for refrigerant storage during normal operation and system pump down.
- Allows the system to adjust to varying system conditions and loads.
- Available in 4", 5" and 6" diameters (2 1/2" and 3" diameter vertical receivers and horizontal receiver models available. Consult Parker).
- Available up to 36" in length.
- Integral 430° F fuse plug.
- Available options: sight glasses, moisture indicators, float balls, valves, mounting brackets, belly bands, relief valve ports.
- Valve is shipped unassembled.
- PTFE gasket seal for valve.
- UL file number SA5195 and CSA file number LR46423.



Standard Steel Receivers

Model Number	Diameter (Inches)	Inlet (A)	Outlet (B)	Overall Length Inches (C)	Holding Capacity
PR4095-10-2	4	1/4 SAE	1/4 SAE	10	4 LBS.
PR5109-10-2	5	1/4 SAE	1/4 SAE	10	6 LBS.
PR5109-10-3	5	3/8 SAE	3/8 SAE	10	6 LBS.
PR6125-12-3	6	3/8 SAE	3/8 SAE	12	10 LBS.
PR6125-18-4	6	1/2 SAE	1/2 SAE	18	16 LBS.

Holding Capacity calculated at 90% system charge at 90 degrees F for R-22 & R134a. For R- 404A & R-507 multiply by 0.9

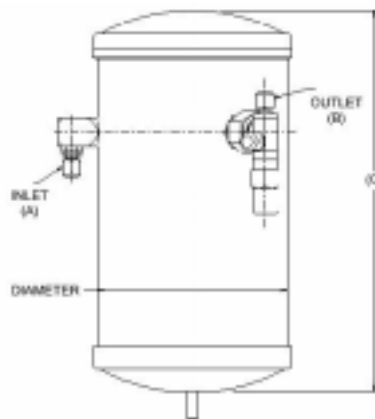

Compensator Tanks

A compensator tank is a mode dependent receiver that can be used in a heat pump system. As the heating mode does not require as much refrigerant as the cooling mode, the compensator tank stores the excess refrigerant.

Key Features and Benefits

- Available with 5/8", 3/4" and 7/8" suction line connections--steel or copper sweat.
- Liquid connections - steel or copper sweat.
- Diameters of 3", 3 1/2" and 4" available.
- Various holding capacities available.
- Corrosion resistant paint gives 500 hour salt spray protection.
- U.L. listed SA5915.

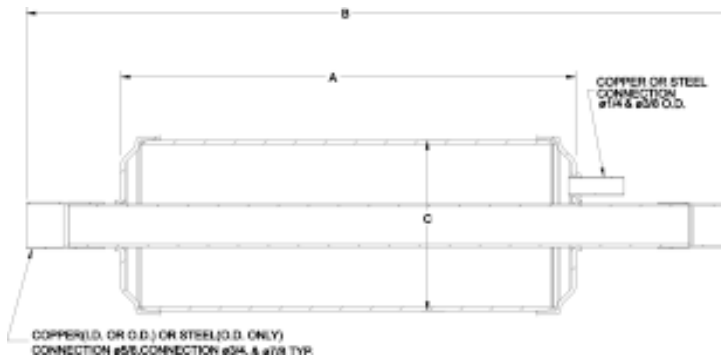

Compensator Tank Refrigerant Holding Capacities

Model	Int. Volume In. ³	Holding Capacities (oz.)		
		22	134a	410A
PR3083-8-7C	45	29.60	30.06	26.35
PR3083-16-7C	89	58.55	59.46	52.12
PR3083-12-7C	66	43.42	44.09	38.65
PR35083-9-7C	72	47.37	48.10	42.17
PR35083-4-7C	31	20.39	20.71	18.16

Densities at 100° F in lb/ft³: - 71.05 72.15 63.25

Compensator Tank Dimensions

Model	"A"	"B"	"C"	Suction Connections	Liq. Line ftg
PR-3083-8-7C	8.25	13.00	3.00	7/8 I.D. x 7/8 O.D.	1/4 O.D.
PR-3083-16-7C	16.00	21.25	3.00	7/8 I.D. x 7/8 O.D.	1/4 O.D.
PR3083-12-6C	12.00	16.00	3.00	3/4 I.D. typ.	1/4 I.D.
PR-35083-9-7C	9.38	14.55	3.50	7/8 I.D. x 7/8 O.D.	3/8 O.D.
PR-35083-4-7C	4.28	8.93	3.50	7/8 I.D. x 7/8 O.D.	3/8 O.D.

Copper Mufflers

Copper mufflers are used primarily to reduce compressor noise which is usually caused by the pressure pulses of the compressor. In some cases, these pulses can be further reduced by using a muffler supplied with internal baffles. The muffler is typically placed in the high pressure vapor line (compressor

outlet). To provide efficient oil movement, mufflers are typically mounted vertically flowing downward. Requirements will vary by system. Consult Parker for proper design and application. Parker copper mufflers are U.L. and CSA recognized.

1-5/8" O.D. Copper Mufflers

Part No.	Design		Inlet Inches	Outlet Inches	Overall Length
	Working Pressure (PSIG)	Baffle Material			
054801-01	500	2 C.R.S.	3/8	3/8	4.00
054801-02	500	2 C.R.S.	1/2	1/2	4.00
031798-00	500	None	3/8	3/8	4.38
031780-00	500	None	1/2	1/2	4.38
031686-01	500	None	3/8	3/8	8.00
422801*	500	None	various		4.3 - 5.3

*5/16, 1/4, 3/8, 1/2 and 5/8 inch outlet and inlet options with one hole are available.

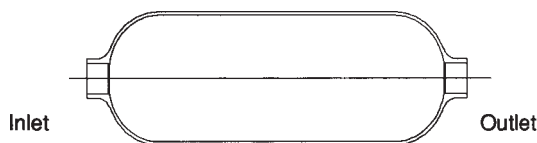

Steel Mufflers

Parker steel mufflers are designed to assist with today's and future compressor related difficulties such as noise reduction due to compressor pulsation and/or turbulent gas flow or vibration through the discharge line.

Key Features and Benefits

- UL/CSA listed for 500 psig design pressure. (Selected models listed at 600 psig - consult Parker for details.)
- 100% pure copper sweat fitting.
- Extended end fittings available.
- Fully welded construction.
- Bi-directional flow.
- Powder coated paint gives maximum corrosion resistance of 500 hour salt spray protection.
- Various fitting combinations and lengths available upon request.
- U.L. listed SA5918.

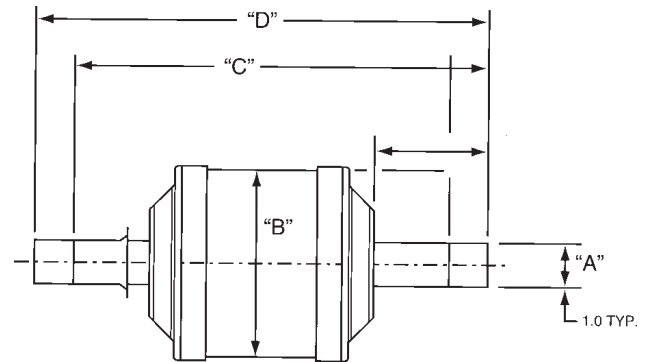

Steel Muffler Dimensions

Model Number	"A" Connections		"B" Diameter (in.)	"C" System Cutout Length	"D" Overall Length (in.)
	Inlet (in.)	Outlet (in.)			
PM25049-3-3C	3/8	3/8	2 1/2	3.36	4.36
PM25049-3-4C	1/2	1/2	2 1/2	3.26	4.50
PM25049-3-4C	1/2	1/2	2 1/2	5.08	6.08
PR25083-X-YC	1/4	5/8	2 1/2	3.09 min - 11.0 max	3.09 min - 11.0 max
PR25083-2-3C	3/8	3/8	2 1/2	1.86	2.96
PR25083-3-2C	1/4	1/4	2 1/2	3.32	4.32
PR25083-3-3C	3/8	3/8	2 1/2	3.36	4.36
PR25083-2-4C	1/2	1/2	2 1/2	2.66	3.09
PR25083-3-4C	1/2	1/2	2 1/2	3.26	4.5
PR25083-3-4C	1/2	1/2	2 1/2	5.08	6.08
PR3083-X-YC	3/8	7/8	3	3.09 min - 11.0 max	3.09 min - 11.0 max
PR3083-4-3C	3/8	3/8	3	3.95	4.95
PR3083-5-4C	1/2	1/2	3	8.13	9.13
PM3083-5-4C	1/2	1/2	3	8.13	9.13
PR3083-8-6C	3/4	3/4	3	8.94	10.32
PR35083-5-7C	7/8	7/8	3 1/2	4.90	6.45
PR35083-8-9C	1 1/8	1 1/8	3 1/2	8.44	10.87

* B dimension does not include weld bead measurement, which is nominal.

Service Valves

Parker offers a variety of service valves to meet your needs, including front seating shut off valves, back

seating shut off valves, mini split valves, and brass angle shut off valves, plus valve cores and adapter kits.

Front Seated Shut Off Valve

The Parker QL 171 series brass valve features a front seating design with a brass-to-brass stem seal. A corrosion resistant body, low pressure drop porting and a tamper proof recessed stem drive are advantages not readily available with steel constructed valves. Schrader valve fittings which allow system pressure checks, evacuation, or charging are available either on the left (L) or right (R) side when looking directly into the field connection.

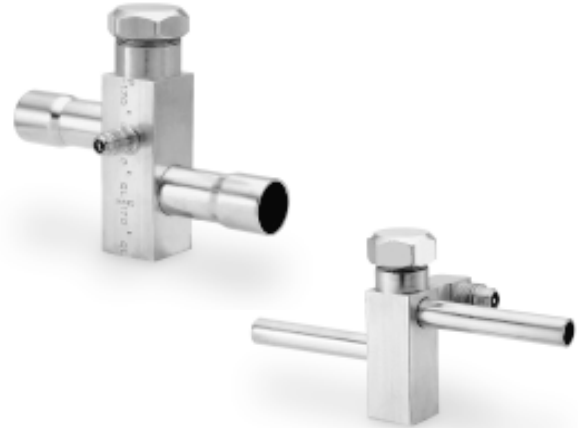

Key Features and Benefits

- All brass body and stem.
- Leak rate: 1/10 ounce per year.
- 3/8" to 7/8" ODF sweat extended copper connections.
- Low cost alternative to ball and/or other type of hand valves.
- Rugged brass construction provides universal replacement for other valves.

- Available as standard base mounted or optional bracket mounted design.
- Valve service gauge port machined for Schrader core.
- U.L. recognized file 3604.

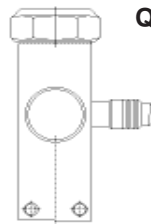

QL171 Right

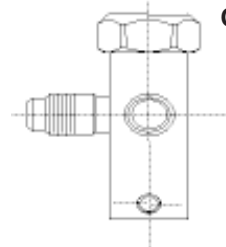

QL171 Left

Front Seating Shut Off Valve Dimensions

Side Mount					
Model Number	"A"	"B"	optional Mounting	"C"	System Cutout
QL171L-06-06	3/8	0.16	single 10-32 UNF THD	0.5	4.58
QL171L-10-10	5/8	0.22	dual holes only	0.92	5.00
QL171R-12-12	3/4	0.22	dual 10-32 UNF	0.75	5.00
QL171L-12-12	3/4	0.22	dual holes only	0.92	5.00
QL171R-14-14	7/8	0.22	dual 10-32 UNF	0.81	5.13
QL171L-14-14	7/8	0.22	dual holes only	0.92	4.74

Bottom Mount					
Model Number	"A"	"B"	optional Mounting	"C"	System Cutout
QL171R-06-06	3/8	N/A	1/4 20 UNC	0.89	4.58
QL171R-08-08	1/2	N/A	1/4 20 UNC	1.07	5.00
QL171R-10-10	5/8	N/A	1/4 20 UNC	1.07	5.00
QL171R-12-12	3/4	N/A	1/4 20 UNC	1.07	5.00
QL171R-14-14	7/8	N/A	1/4 20 UNC	1.17	5.13

Side Mount

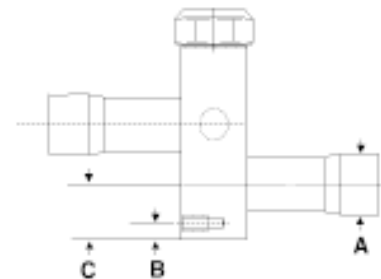

Bottom Mount

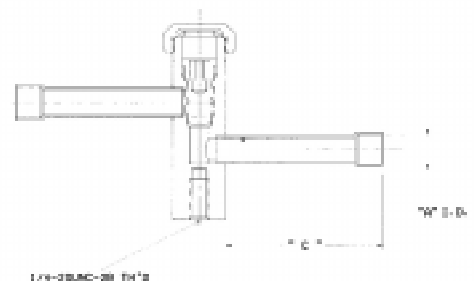

*L or R designate gage port location when looking directly into field connection.

**Specify desired mounting style when ordering.

Mini Split Shut Off Valves

This compact foot mounted design incorporates the same all brass stem to brass seat design as Parker's QL 170 & 171 series, ensuring a reliable and remakeable seal. Full depth sweat fittings permit fast and reliable brazing to the factory side, while standard SAE flare connections ease and speed up the field installation side.



Key Features and Benefits

- 100% forged brass body.
- Full flow low pressure drop porting.
- Schrader service valve fitting is available.
- Flow rater fittings are available (contact Parker).
- Fitting sizes: 3/8", 1/2", 5/8", 3/4" & 7/8".
- Foot mounted design with two holes for rigid support.
- Other factory end connections and designs available (contact Parker).
- U.L. recognized file 3604.

QL191

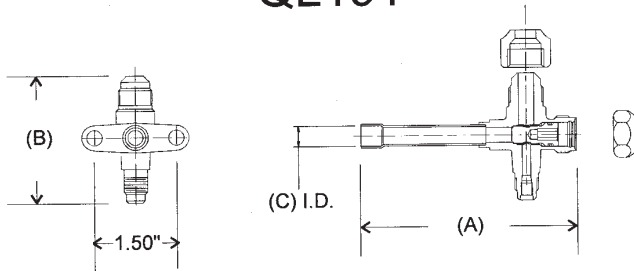

QL190

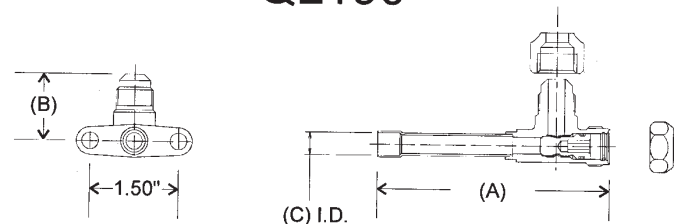

Mini Split Valve Dimensions

Fitting Size	Model Numbers							
	QL 191 (with gauge port)	"A"	"B"	"C"	QL 190 (w/o gauge port)	"A"	"B"	"C"
1/4	QL 191-4-4	3.77	2.35	0.26	QL 190-4-4	3.77	1.15	0.26
3/8	QL 191-6-6	3.94	2.35	0.38	QL 190-6-6	3.94	1.15	0.38
1/2	QL 191-8-8	4.46	2.74	0.51	N/A			
5/8	QL 191-10-10	3.01	2.74	0.63	N/A			
3/4	QL 191-12-12	3.17	2.85	0.76	N/A			

Also available:

Adapter Tool Kit No. 053983-00

Two Hex drive adapters fit standard refrigeration ratchet wrenches to help install QL series valves.

Adapter Kit Carrier No. 054258-00

Three hex drive adapters to fit Carrier unit valves.

Brass Angle Shut Off Valves

The Parker brass backseating angle shut-off valve features a patented sealing surface. Using a high tensile strength steel stem, a unique brass ovet is affixed to the lower portion of the stem, incorporating either a PTFE seal (TS) or a special metal seal (AV) to ensure tight shut off and remakeability.

Key Features and Benefits

- All brass body.
- 1/4" external SAE, full gauge port.
- Seal cap designed for use with halocarbons, new refrigerants and blends.
- Sweat I.D. socket connections are standard.
- Other type connections (NPT, flare) are available. Contact Parker.

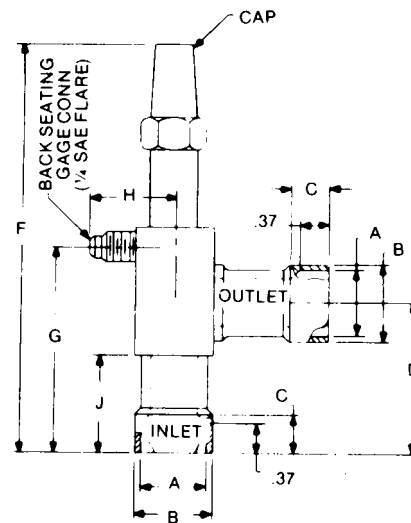
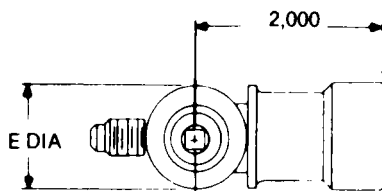

Brass Angle Shut Off Valve Dimensions

Index	MFR. No.	Connection Nom. I.D.	"A"	"B"	"C"	"D"	"E"	"F" Ref.	"G"	"H"	"J"
	TS58	5/8	0.631	0.749	-	1.910	1.000	4 7/8	2.530	1.0500	1.25
	AV58	5/8	0.627	0.745	-	1.910	1.000	4 7/8	2.530	1.0500	1.25
	TS78	7/8	0.881	0.999	0.5	1.970	1.130	5 1/4	2.650	1.1100	1.25
	AV78	7/8	0.877	0.995	0.5	1.970	1.130	5 1/4	2.650	1.1100	1.25
	AV125	1 1/8	1.131	1.374	0.5	2.080	1.380	5 1/2	2.870	1.2300	1.36
	PTFE Seal	1 1/8	1.127	1.370	0.5	2.080	1.380	5 1/2	2.870	1.2300	1.36
	TS50	1 1/2	0.502	0.750	0.5	1.375	0.875	4 1/8	2.000	1.1875	0.91
	AV50	1 1/2	0.505	0.745	0.5	1.375	0.875	4 1/8	2.000	1.1875	0.91

Check Valves

Check valves are designed to allow flow in one direction only. They are used to prevent backwards flow through dryers, strainers and other devices that are designed for directional flow.

Copper Ball Check Valve

Parker ball check valves contain a stainless steel ball that is in a one piece brass seat and retainer assembled in a copper tube. The materials of construction are corrosion proof and allow the check valve to be used at a wide range of operating temperatures and conditions. *Spring loaded versions are available upon request.*

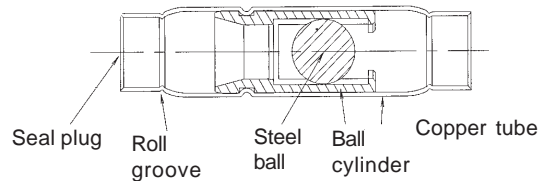

Key Features and Benefits

- Straight flow through design yields high flow capacities for small diameter valve bodies.
- Metal-to-metal seating - stainless steel to brass
- Corrosion resistant construction (stainless steel, brass, copper).
- Leak rate - dry: 750 cc/min.
- UL recognized for 500 psig design pressure file no. SA3604.
- Small body diameter.

- One piece body construction eliminates leaks.
- All metal design allows for higher installation and operating temperatures.
- **NOTE:** Valves should be installed at an angle to ensure proper seating in off cycle.

Copper Ball Check Valve Data

Model No.	UL Model	Female Sweat Connect	Overall Length	System Cutout Length	Body Dia.	Flow -lons* @ 1 psi pressure drop													
						12	22	134a	401A/B	401C	402A	402B	404A	407A	407B	407C	410A	502	507A
CV4-6FS-6FS	3/8F	3/8	3 3/4	3	1/2	2.6	3.5	3.2	3.6	3.2	2.4	2.8	2.3	3.1	2.5	3.4	3.4	2.3	2.3
CV5-8FS-8FS	1/2F	1/2	3 3/4	2 7/8	5/8	4.8	6.4	5.8	6.6	5.8	4.3	5.0	4.2	5.6	4.5	6.2	6.3	4.2	4.2
CV7-10FS-10FS	5/8F	5/8	4 1/2	3 1/2	7/8	9.0	12.0	10.9	12.3	11.0	8.1	9.5	7.8	10.5	8.4	11.6	11.8	7.8	7.8
CV9-14FS-14FS	7/8F	7/8	4 1/2	3 1/2	1 1/8	18.6	24.8	22.5	25.4	22.6	16.7	19.5	16.1	21.6	17.4	23.9	24.3	16.1	16.1
CV11-18FS-18FS	1 1/8F	1 1/8	5	4	1 3/8	48.8	65.0	59.1	66.7	59.3	43.9	51.2	42.2	56.8	45.6	62.9	64.0	42.4	42.3

Rated at 86°F liquid / 5°F evaporator.

Soft Seat Copper Check Valve

Instead of the metal-metal seating found in many check valves, this Parker valve features a neoprene O-ring that seals to a brass seat. This “soft seat” design guarantees virtually no leakage of refrigerant.

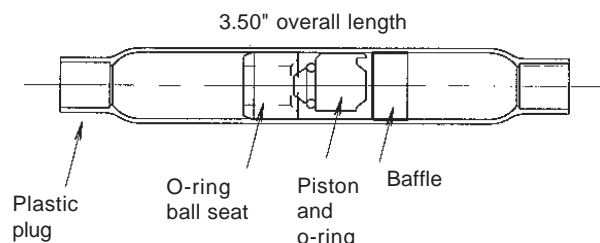

Key Features and Benefits

- Neoprene o-ring seal is compatible with currently used HCFCs, HFCs and their associated lubricants.
- Ideal for refrigeration and air conditioning applications where extremely low leakage is a requirement.
- After 300,000 cycles, at a 100 psi differential pressure, maximum leak rate is 10 cc/minute. Traditional check valves have leak rates of up to 750cc a minute.
- Features a brass piston and a steel piston stop.
- Valve sizes available are 1/4”, 5/16” and 3/8”.
- Operating temperature range of -40° to 300° F.

1/4" Brass Check Valve

- Poppet style valve incorporates o-ring sealing surface.
- Brass body and piston resist corrosion.
- Stainless steel spring resists corrosion.
- Braze connections.

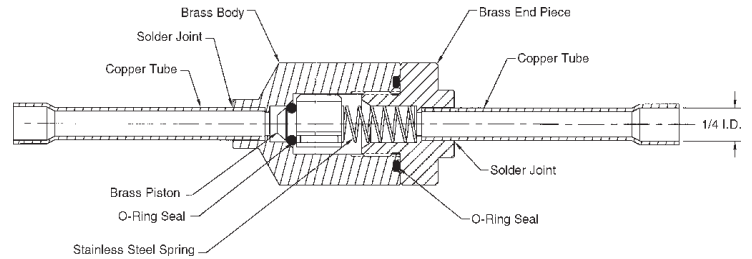
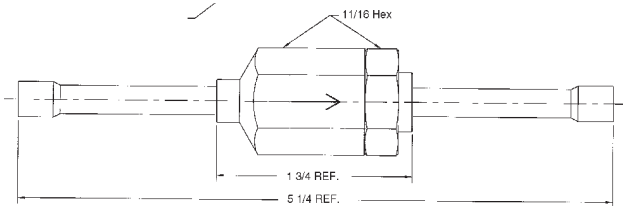

3/8" Brass Check Valve

- Poppet style valve incorporates o-ring sealing surface.
- Brass body and piston resist corrosion.
- Stainless steel spring resists corrosion.
- Braze connections.

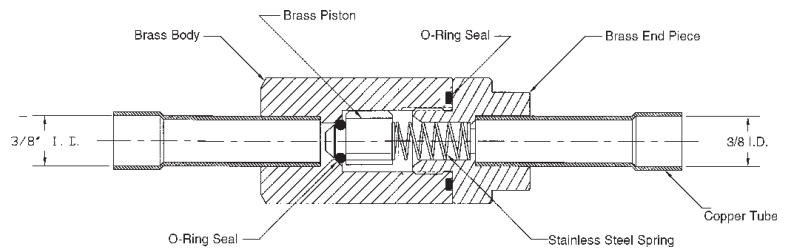
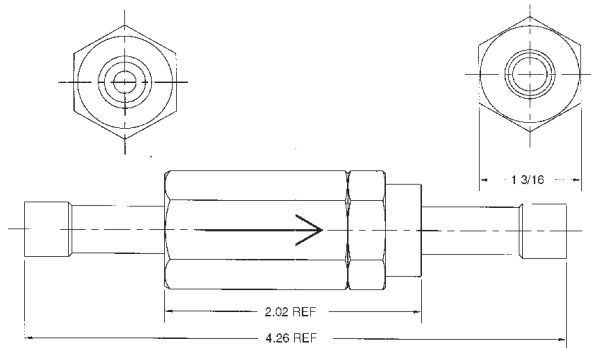

1/8" NPT Brass Check Valve

- Poppet style valve incorporates o-ring sealing surface.
- Brass body and piston resist corrosion.
- Stainless steel spring resists corrosion.
- Female NPT threaded connections.

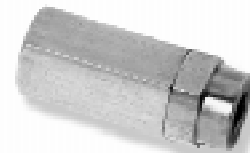
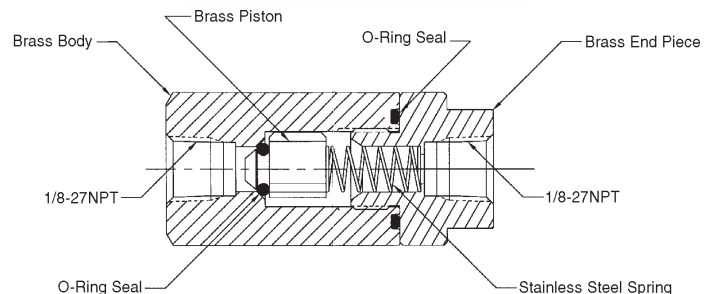
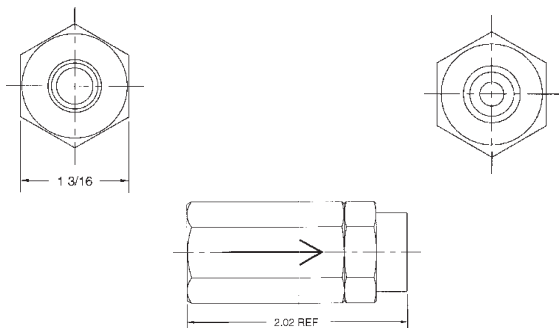

Sight Glass and Moisture Indicators

Key Features and Benefits

- Available in all popular end connections up to 2 1/8"
- Solid copper extended sweat fittings permit solder installation without disassembly.
- Flare models feature forged brass body and fittings.
- Compact design, low silhouette, short laying in length.
- Extremely accurate.
- Easy viewing.
- U.L. listed File No. SA4744.



Sight Glass

Moisture Indicator Dimensions

Model No.	Fitting Size	Fitting Type	Overall Length (in.)	Cut Out Length (in.)
PSG-2	1/4"	SAE Male Flare	3.42	--
PSG-3	3/8"	SAE Male Flare	3.56	--
PSG-4	1/2"	SAE Male Flare	3.82	--
PSG-5	5/8"	SAE Male Flare	4.06	--
PSG-2MF	1/4"	SAE Male x Female Flare	3.05	--
PSG-3MF	3/8"	SAE Male x Female Flare	3.17	--
PSG-4MF	1/2"	SAE Male x Female Flare	3.39	--
PSG-5MF	5/8"	SAE Male x Female Flare	3.69	--
PSG-10T	Replacement indicator element and o-ring.			
PSG-2S	1/4"	Sweat	4.88	4.19
PSG-3S	3/8"	Sweat	4.88	4.12
PSG-4S	1/2"	Sweat	4.88	3.87
PSG-5S	5/8"	Sweat	4.88	3.62
PSG-7S	7/8"	Sweat	6.25	4.73
PSG-9S	1 1/8"	Sweat	6.25	4.45
PSG-11S	1 3/8"	Sweat	7.97	6.03
PSG-13S	1 5/8"	Sweat	7.97	5.79
PSG-17S	2 1/8"	Sweat	7.97	5.47

Moisture color indications in PPM at liquid specific temperatures

System Refrigerant	12	22	134a	401A	401B/C	404A	410A	502	507A	
Liquid Line Temperature	75°F	75°F	75°F	75°F	75°F	75°F	75°F	75°F	75°F	
System Conditions	Indicator Color									
Dry	Green	below 5	below 30	below 35	below 120	below 50	below 40	below 69	below 10	below 33
Caution	Yellow/Green	5 - 15	30-110	35-120	120-420	50-175	40-140	69-240	10-50	33-115
Wet	Yellow	above 15	above 110	above 120	above 420	above 175	above 140	above 240	above 50	above 115

Immediate steps should be taken to protect the system when moisture indicating element shows "Wet". The best protection system available is a Parker Liquid Filter Dryer and Parker Suction Line Filter Dryer. The sight-glass moisture indicator should normally be installed between a Parker Liquid Line Filter Dryer and a refrigerant control device.

Wet-Tec™ Electronic Moisture Sensor

The Wet-Tec™ Moisture Sensor uses an optic-electronic transducer to recognize the color changes (corresponding with changes in relative humidity) in Parker's industry-proven cobalt bromide paper. The user is provided a low voltage DC signal output, which correlates with a wet or dry system.



Key Features and Benefits

- Allows remote monitoring of system moisture levels.
- Low power consumption.
- Compatible with all common and alternative refrigerants (except ammonia).
- Universal mounting.
- Long life.
- Input voltage - 12 or 24VDC, 0.03A Max
- Output voltage - 2-5VDC
- UL listed for 500 PSI SWP
- Available in SAE flare connections up to 5/8".
- Available in ODS sweat connections up to 2 1/8".

Nomenclature

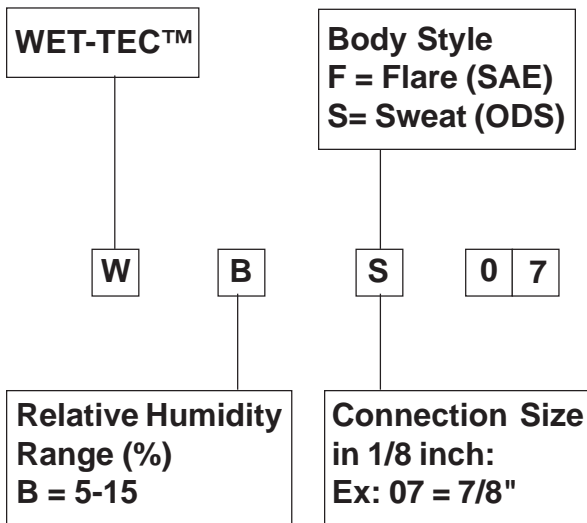

Principles of Operation

How It Works

The Wet-Tec™ Moisture Sensor uses a 12 or 24VDC input signal to interpret the color of the cobalt bromide paper, which changes according to the system's moisture level. An output signal of 2VDC correlates to a "dry" system, while an output signal of 5VDC means a "wet" or unsafe system condition.

Recommended Use

This device is intended to distinguish between acceptable and unacceptable moisture levels, in terms of relative humidity. Relative humidity is a function of refrigerant temperature and PPM of dissolved water as shown in Figure 1. Therefore, in order to make a PPM comparison to the DRY/WET output signal of the Wet-Tec Moisture Sensor, the refrigerant temperature must be considered.

Temperature Compensation

Since the Wet-Tec is a refrigerant relative humidity sensor, it is directly dependent upon the temperature of the refrigerant that passes through it. The Wet-Tec is most effective when used in a refrigerant temperature that remains relatively constant, such as a liquid refrigerant exiting a mechanical subcooler.

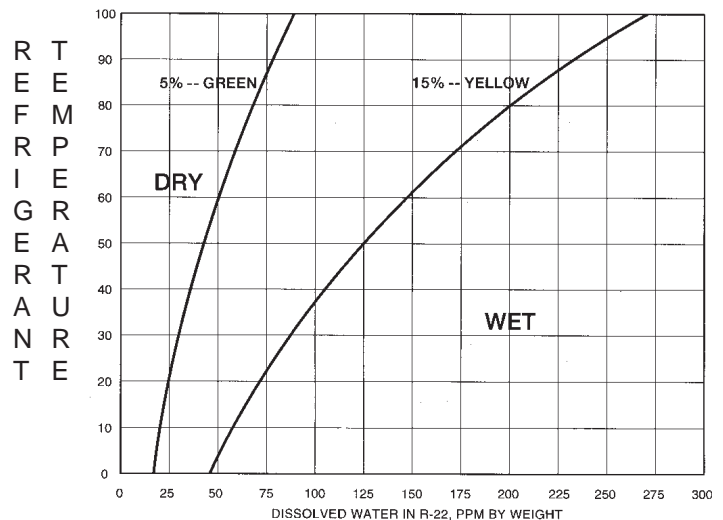

Temp		R-12	R-22	R-123	R-134a	R-502	AZ-50 R-507	R-717
°F	°C							
-50	-45.6	<i>391.2</i>	<i>157.5</i>	<i>741.7</i>	<i>467.4</i>	<i>5.1</i>	0.1	<i>365.8</i>
-45	-42.8	<i>337.8</i>	<i>68.6</i>	<i>736.6</i>	<i>421.6</i>	0.1	0.2	<i>299.7</i>
-40	-40.0	<i>279.4</i>	0.0	<i>734.1</i>	<i>373.4</i>	0.3	0.4	<i>223.5</i>
-35	-37.2	<i>213.4</i>	0.2	<i>729.0</i>	<i>312.4</i>	0.4	0.6	<i>139.7</i>
-30	-34.4	<i>139.7</i>	0.3	<i>721.4</i>	<i>246.4</i>	0.6	0.8	<i>43.2</i>
-25	-31.7	<i>58.7</i>	0.5	<i>713.7</i>	<i>172.7</i>	0.8	1.0	0.1
-20	-28.9	0.0	0.7	<i>706.1</i>	<i>91.4</i>	1.1	1.2	0.2
-15	-26.1	0.2	0.9	<i>696.0</i>	<i>2.5</i>	1.3	1.5	0.4
-10	-23.3	0.3	1.1	1.9	0.1	1.6	1.8	0.6
-5	-20.6	0.5	1.4	1.8	0.3	1.8	2.1	0.8
0	-17.8	0.6	1.7	1.8	0.4	2.1	2.4	1.1
5	-15.0	0.8	1.9	1.7	0.6	2.5	2.8	1.3
10	-12.2	1.0	2.3	1.7	0.8	2.8	3.2	1.6
15	-9.4	1.2	2.6	1.6	1.0	3.2	3.6	2.0
20	-6.7	1.4	3.0	1.6	1.3	3.6	4.1	2.3
25	-3.9	1.7	3.4	1.5	1.5	4.1	4.5	2.7
30	-1.1	2.0	3.8	1.4	1.8	4.5	5.1	3.1
35	1.7	2.2	4.2	1.3	2.1	5.0	5.6	3.5
40	4.4	2.5	4.7	1.2	2.4	5.6	6.2	4.0
45	7.2	2.9	5.2	1.1	2.8	6.1	6.8	4.6
50	10.0	3.2	5.8	1.0	3.1	6.7	7.5	5.1
55	12.8	3.6	6.4	0.9	3.5	7.4	8.2	5.7
60	15.6	4.0	7.0	0.8	4.0	8.0	9.0	6.4
65	18.3	4.4	7.7	0.6	4.4	8.8	9.7	7.1
70	21.1	4.8	8.4	0.5	4.9	9.5	10.6	7.8
75	23.9	5.3	9.1	0.3	5.4	10.3	11.5	8.7
80	26.7	5.8	9.9	0.1	6.0	11.1	12.4	9.5
85	29.4	6.3	10.8	0.1	6.6	12.0	13.4	10.4
90	32.2	6.9	11.6	0.2	7.2	12.9	14.5	11.4
95	35.0	7.4	12.6	0.3	7.8	13.9	15.6	12.5
100	37.8	8.1	13.5	0.4	8.6	14.9	16.8	13.6
105	40.6	8.8	14.6	0.6	9.3	16.0	17.4	14.8
110	43.3	9.4	15.6	0.7	10.1	17.1	19.4	16.0
115	46.1	10.1	16.8	0.9	10.9	18.3	20.8	17.3
120	48.9	10.9	17.9	1.0	11.8	19.5	22.2	18.7
125	51.7	11.7	19.2	1.2	12.7	20.8	23.7	20.2
130	54.4	12.5	20.5	1.4	13.7	22.1	25.4	21.7
135	57.2	13.3	21.9	1.6	14.7	23.5	27.1	23.4
140	60.0	14.3	23.3	1.8	15.8	25.0	28.9	25.1
145	62.8	15.2	24.8	2.1	16.9	26.6	30.8	26.9
150	65.6	16.2	26.3	2.3	18.1	28.2	32.8	28.8

Black figures = bar

Italics = millimeters Hg. Below 1 ATM

Temp		MP 39 R-401A		HP 80 R-402A		HP 62 R-404A	FX 10 R-408A	FX 56 R-409A		AZ 20 R-410A
°F	°C	Liquid	Vapor	Liquid	Vapor	Liquid	Liquid	Liquid	Vapor	
-50	-45.6	-	-	-	-	0.0	0.1	0.9	1.2	0.3
-45	-42.8	-	-	-	-	0.2	0.1	0.7	1.0	0.5
-40	-40.0	205.7	335.3	0.5	0.4	0.3	0.2	0.5	0.9	0.8
-35	-37.2	129.5	271.8	0.7	0.6	0.5	0.4	0.2	0.7	1.0
-30	-34.4	43.2	200.7	0.9	0.8	0.7	0.6	0.0	0.6	1.3
-25	-31.7	0.1	121.9	1.1	1.1	0.9	0.8	0.1	0.4	1.6
-20	-28.9	0.2	35.6	1.4	1.3	1.2	1.0	0.3	0.1	1.9
-15	-26.1	0.4	0.1	1.6	1.6	1.4	1.2	0.4	0.1	2.2
-10	-23.3	0.5	0.2	1.9	1.9	1.7	1.5	0.6	0.2	2.5
-5	-20.6	0.7	0.4	2.2	2.2	2.0	1.7	0.8	0.3	2.9
0	-17.8	0.9	0.6	2.6	2.5	2.3	2.0	1.0	0.5	3.4
5	-15.0	1.1	0.7	3.0	2.9	2.7	2.4	1.2	0.7	3.8
10	-12.2	1.4	0.9	3.4	3.3	3.0	2.7	1.5	0.9	4.3
15	-9.4	1.6	1.2	3.8	3.7	3.4	3.1	1.8	1.1	4.8
20	-6.7	1.9	1.4	4.3	4.2	3.9	3.5	2.0	1.3	5.4
25	-3.9	2.2	1.7	4.8	4.7	4.3	3.9	2.3	1.5	6.0
30	-1.1	2.5	2.0	5.3	5.2	4.8	4.4	2.7	1.8	6.7
35	1.7	2.8	2.3	5.9	5.8	5.4	4.9	3.0	2.1	7.4
40	4.4	3.2	2.6	6.5	6.4	6.0	5.4	3.4	2.4	8.1
45	7.2	3.6	2.9	7.2	7.0	6.6	6.0	3.8	2.7	9.0
50	10.0	4.0	3.3	7.9	7.7	7.2	6.6	4.2	3.1	9.8
55	12.8	4.5	3.7	8.6	8.5	7.9	7.2	4.7	3.4	10.8
60	15.6	5.0	4.2	9.4	9.2	8.6	7.9	5.1	3.8	11.7
65	18.3	5.5	4.6	10.1	10.1	9.4	8.7	5.6	4.3	12.8
70	21.1	6.0	5.1	11.0	10.9	10.2	9.4	6.2	4.7	13.9
75	23.9	6.6	5.7	11.9	11.8	11.1	10.3	6.7	5.2	15.0
80	26.7	7.2	6.2	12.9	12.8	12.0	11.1	7.3	5.8	16.2
85	29.4	7.9	6.8	13.9	13.8	13.0	12.0	8.0	6.3	17.5
90	32.2	8.5	7.4	15.0	14.8	14.0	13.0	8.6	6.9	18.9
95	35.0	9.2	8.1	16.1	16.0	15.1	14.0	9.3	7.5	20.3
100	37.8	10.0	8.8	17.3	17.2	16.3	15.1	10.1	8.2	21.9
105	40.6	10.8	9.6	18.6	18.4	17.5	16.2	10.8	8.9	23.5
110	43.3	11.7	10.4	19.9	19.7	18.7	17.4	11.7	9.7	25.2
115	46.1	12.5	11.2	21.2	21.0	20.1	18.6	12.5	10.5	27.0
120	48.9	13.4	12.1	22.5	22.5	21.5	19.9	13.4	11.4	28.8
125	51.7	14.4	13.0	24.1	23.9	22.9	21.3	14.3	12.3	30.8
130	54.4	15.4	14.0	25.7	25.5	24.4	22.7	15.3	13.2	32.8
135	57.2	16.5	15.0	27.3	27.1	26.1	24.2	16.4	14.2	35.0
140	60.0	17.6	16.1	29.0	28.8	27.7	25.8	17.4	15.3	37.2
145	62.8	18.8	17.2	30.8	30.6	29.5	27.5	18.6	16.4	39.5
150	65.6	20.6	18.4	32.6	32.4	31.3	29.2	20.2	19.8	41.9

 **WARNING**

FAILURE OR IMPROPER SELECTION OR IMPROPER USE OF THE PRODUCTS AND/OR SYSTEMS DESCRIBED HEREIN OR RELATED ITEMS CAN CAUSE DEATH, PERSONAL INJURY AND PROPERTY DAMAGE.

This document and other information from Parker Hannifin Corporation, its subsidiaries and authorized distributors provide product and/or system options for further investigation by users having technical expertise. It is important that you analyze all aspects of your application and review the information concerning the product or system in the current product catalog. Due to the variety of operating conditions and applications for these products or systems, the user, through its own analysis and testing, is solely responsible for making the final selection of the products and systems and assuring that all performance, safety and warning requirements of the application are met.

The products described herein, including without limitation, product features, specifications, designs, availability and pricing, are subject to change by Parker Hannifin Corporation and its subsidiaries at any time without notice.

Offer of Sale

The items described in this document are hereby offered for sale by Parker Hannifin Corporation, its subsidiaries or its authorized distributors. This offer and its acceptance are governed by the provisions stated in the "Offer of Sale".

© Copyright 1999, Parker Hannifin Corporation, All Rights Reserved

The items described in this document and other documents or descriptions provided by Parker Hannifin Corporation, its subsidiaries and its authorized distributors are hereby offered for sale at prices to be established by Parker Hannifin Corporation, its subsidiaries and its authorized distributors. This offer and its acceptance by any customer ("Buyer") shall be governed by all of the following Terms and Conditions. Buyer's order for any such items, when communicated to Parker Hannifin Corporation, its subsidiary or an authorized distributor ("Seller") verbally or in writing, shall constitute acceptance of this offer.

1. Terms and Conditions of Sale: All descriptions, quotations, proposals, offers, acknowledgments, acceptances and sales of Seller's products are subject to and shall be governed exclusively by the terms and conditions stated herein. Buyer's acceptance of any offer to sell is limited to these terms and conditions. Any terms or conditions in addition to, or inconsistent with those stated herein, proposed by Buyer in any acceptance of an offer by Seller, are hereby objected to. No such additional, different or inconsistent terms and conditions shall become part of the contract between Buyer and Seller unless expressly accepted in writing by Seller. Seller's acceptance of any offer to purchase by Buyer is expressly conditional upon Buyer's assent to all the terms and conditions stated herein, including any terms in addition to, or inconsistent with those contained in Buyer's offer. Acceptance of Seller's products shall in all events constitute such assent.

2. Payment: Payment shall be made by Buyer net 30 days from the date of delivery of the items purchased hereunder. Amounts not timely paid shall bear interest at the maximum rate permitted by law for each month or portion thereof that the Buyer is late in making payment. Any claims by Buyer for omissions or shortages in a shipment shall be waived unless Seller receives notice thereof within 30 days after Buyer's receipt of the shipment.

3. Delivery: Unless otherwise provided on the face hereof, delivery shall be made F.O.B. Seller's plant. Regardless of the method of delivery, however, risk of loss shall pass to Buyer upon Seller's delivery to a carrier. Any delivery dates shown are approximate only and Seller shall have no liability for any delays in delivery.

4. Warranty: Seller warrants that the items sold hereunder shall be free from defects in material or workmanship for a period of 18 months from date of shipment from Parker Hannifin Corporation. **THIS WARRANTY COMPRISES THE SOLE AND ENTIRE WARRANTY PERTAINING TO ITEMS PROVIDED HEREUNDER. SELLER MAKES NO OTHER WARRANTY, GUARANTEE, OR REPRESENTATION OF ANY KIND WHATSOEVER. ALL OTHER WARRANTIES, INCLUDING BUT NOT LIMITED TO, MERCHANTABILITY AND FITNESS FOR PURPOSE, WHETHER EXPRESS, IMPLIED, OR ARISING BY OPERATION OF LAW, TRADE USAGE, OR COURSE OF DEALING ARE HEREBY DISCLAIMED. NOTWITHSTANDING THE FOREGOING, THERE ARE NO WARRANTIES WHATSOEVER ON ITEMS BUILT OR ACQUIRED WHOLLY OR PARTIALLY, TO BUYER'S DESIGNS OR SPECIFICATIONS.**

5. Limitation Of Remedy: SELLER'S LIABILITY ARISING FROM OR IN ANY WAY CONNECTED WITH THE ITEMS SOLD OR THIS CONTRACT SHALL BE LIMITED EXCLUSIVELY TO REPAIR OR REPLACEMENT OF THE ITEMS SOLD OR REFUND OF THE PURCHASE PRICE PAID BY BUYER, AT SELLER'S SOLE OPTION. IN NO EVENT SHALL SELLER BE LIABLE FOR ANY INCIDENTAL, CONSEQUENTIAL OR SPECIAL DAMAGES OF ANY KIND OR NATURE WHATSOEVER, INCLUDING BUT NOT LIMITED TO LOST PROFITS ARISING FROM OR IN ANY WAY CONNECTED WITH THIS AGREEMENT OR ITEMS SOLD HEREUNDER, WHETHER ALLEGED TO ARISE FROM BREACH OF CONTRACT, EXPRESS OR IMPLIED WARRANTY, OR IN TORT, INCLUDING WITHOUT LIMITATION, NEGLIGENCE, FAILURE TO WARN OR STRICT LIABILITY.

6. Changes, Reschedules and Cancellations: Buyer may request to modify the designs or specifications for the items sold hereunder as well as the quantities and delivery dates thereof, or may request to cancel all or part of this order, however, no such requested modification or cancellation shall become part of the contract between Buyer and Seller unless accepted by Seller in a written amendment to this Agreement. Acceptance of any such requested modification or cancellation shall be at Seller's discretion, and shall be upon such terms and conditions as Seller may require.

7. Special Tooling: A tooling charge may be imposed for any special tooling, including without limitation, dies, fixtures, molds and patterns, acquired to manufacture items sold pursuant to this contract. Such special tooling shall be and remain Seller's property notwithstanding payment of any charges by Buyer. In no event will Buyer acquire any interest in apparatus belonging to Seller which is utilized in the notwithstanding any charges paid by Buyer. Unless otherwise agreed, Seller shall have the right to alter, discard or otherwise dispose of any special tooling or other

property in its sole discretion at any time.

8. Buyer's Property: Any designs, tools, patterns, materials, drawings, confidential information or equipment furnished by Buyer or any other items which become Buyer's property, may be considered obsolete and may be destroyed by Seller after two (2) consecutive years have elapsed without Buyer placing an order for the items which are manufactured using such property, Seller shall not be responsible for any loss or damage to such property while it is in Seller's possession or control.

9. Taxes: Unless otherwise indicated on the face hereof, all prices and charges are exclusive of excise, sales, use, property, occupational or like taxes which may be imposed by any taxing authority upon the manufacture, sale or delivery of the items sold hereunder. If any such taxes must be paid by Seller or if Seller is liable for the collection of such tax, the amount thereof shall be in addition to the amounts for the items sold. Buyer agrees to pay all such taxes or to reimburse Seller therefore upon receipt of its invoice. If Buyer claims exemption from any sales, use or other tax imposed by any taxing authority, Buyer shall save Seller harmless from and against any such tax, together with any interest or penalties thereon which may be assessed if the items are held to be taxable.

10. Indemnity For Infringement of Intellectual Property Rights: Seller shall have no liability for infringement of any patents, trademarks, copyrights, trade dress, trade secrets or similar rights except as provided in this Part 10. Seller will defend and indemnify Buyer against allegations of infringement of U.S. Patents, U.S. Trademarks, copyrights, trade dress and trade secrets (hereinafter 'Intellectual Property Rights'). Seller will defend at its expense and will pay the cost of any settlement or damages awarded in an action brought against Buyer based on an allegation that an item sold pursuant to this contract infringes the Intellectual Property Rights of a third party. Seller's obligation to defend and indemnify Buyer is contingent on Buyer notifying Seller within ten (10) days after Buyer becomes aware of such allegations of infringement, and Seller having sole control over the defense of any allegations or actions including all negotiations for settlement or compromise. If an item sold hereunder is subject to a claim that it infringes the Intellectual Property Rights of a third party, Seller may, at its sole expense and option, procure for Buyer the right to continue using said item, replace or modify said item so as to make it noninfringing, or offer to accept return of said item and return the purchase price less a reasonable allowance for depreciation. Notwithstanding the foregoing, Seller shall have no liability for claims of infringement based on information provided by Buyer, or directed to items delivered hereunder for which the designs are specified in whole or part by Buyer, or infringements resulting from the modification, combination or use in a system of any item sold hereunder. The foregoing provisions of this Part 10 shall constitute Seller's sole and exclusive liability and Buyer's sole and exclusive remedy for infringement of Intellectual Property Rights. If a claim is based on information provided by Buyer or if the design for an item delivered hereunder is specified in whole or in part by Buyer, Buyer shall defend and indemnify Seller for all costs, expenses or judgments resulting from any claim that such item infringes any patent, trademark, copyright, trade dress, trade secret or any similar right.

11. Force Majeure: Seller does not assume the risk of and shall not be liable for delay or failure to perform any of Seller's obligations by reason of circumstances beyond the reasonable control of Seller (hereinafter 'Events of Force Majeure'). Events of Force Majeure shall include without limitation, accidents, acts of God, strikes or labor disputes, acts, laws, rules or regulations of any government or government agency, fires, floods, delays or failures in delivery of carriers or suppliers, shortages of materials and any other cause beyond Seller's control.

12. Entire Agreement/Governing Law: The terms and conditions set forth herein, together with any amendments, modifications and any different terms or conditions expressly accepted by Seller in writing, shall constitute the entire Agreement concerning the items sold, and there are no oral or other representations or agreements which pertain thereto. This Agreement shall be governed in all respects by the law of the State of Ohio. No actions arising out of the sale of the items sold hereunder or this Agreement may be brought by either party more than two (2) years after the cause of action accrues.

9/91-P



Parker Hannifin Corporation
Climate & Industrial Controls Group
6035 Parkland Blvd.
Cleveland, Ohio 44124-4141
Telephone: (216) 896-3000
Fax: (216) 896-4008
Web site: www.parker.com/cig

About Parker's Climate & Industrial Controls Group

The Climate and Industrial Controls Group is one of Parker's eight global operating groups. The Group is a leader in the design, manufacture and sale of system controls and protectors to refrigeration and air-conditioning customers worldwide. The Group also provides a wide variety of industrial controls, including solenoid valves, process control valves, and gerotors, for a multitude of applications.



The Climate Controls Division is a leader in the development, design, manufacture and service of thermostatic expansion valves (TXVs) and refrigerant distributors.



The Refrigeration and Air Conditioning Division designs, manufactures and markets system protectors for mobile and stationary refrigeration and air conditioning applications. Products include filter dryers, receivers, accumulators, mufflers, check valves, and spun copper components.



The Skinner Valve Division designs, produces and markets a full spectrum of refrigeration and general purpose solenoid valves. Brand names include Jackes-Evans, Gold Ring, and Skinner.



The Lucifer Valve Division designs, manufactures and distributes industrial solenoid valves for a variety of applications.



The Sinclair Collins Division is a leading manufacturer and supplier of process control valves for a variety of industrial applications.



The Refrigerating Specialties Division manufactures a comprehensive line of valves and related components for use with both ammonia and halocarbon refrigerants in commercial and industrial refrigeration applications.



The Automotive Connectors Division designs, produces and markets quality air conditioning hose and fittings for automotive, heavy duty truck and off-highway applications worldwide.



The Nichols Portland Division is a world leader in the manufacture of gerotors. These products are used in pumping applications wherever fluid needs to be transferred from one place to another.





Parker Hannifin Corporation
 6035 Parkland Blvd.
 Cleveland, Ohio 44124-4141
 Telephone: (216) 896-3000
 Fax: (216) 896-4000
 Web site: www.parker.com

Parker Hannifin Corporation

About Parker Hannifin Corporation

Parker Hannifin is a leading global motion-control company dedicated to delivering premier customer service. A Fortune 500 corporation listed on the New York Stock Exchange (PH), our components and systems comprise over 1,400 product lines that control motion in some 1,000 industrial and aerospace markets. Parker is the only manufacturer to offer its customers a choice of hydraulic, pneumatic, and electromechanical motion-control solutions. Our Company has the largest distribution network in its field, with over 7,500 distributors serving more than 400,000 customers worldwide.

Parker's Charter

To be a leading worldwide manufacturer of components and systems for the builders and users of durable goods. More specifically, we will design, market and manufacture products controlling motion, flow and pressure. We will achieve profitable growth through premier customer service.

Product Information

North American customers seeking product information, the location of a nearby distributor, or repair services will receive prompt attention by calling the Parker Product Information Center at our toll-free number: 1-800-C-PARKER (1-800-272-7537). In the UK, a similar service is available by calling 0500-103-203.

The Aerospace Group is a leader in the development, design, manufacture and servicing of control systems and components for aerospace and related high-technology markets, while achieving growth through premier customer service.



The Climate & Industrial Controls Group designs, manufactures and sells system controls and protectors to refrigeration and air-conditioning customers worldwide. The Group also provides solenoid valves, process control valves, and gerotors for a multitude of industrial applications.

The Fluid Connectors Group designs, manufactures and markets rigid and flexible connectors, and associated products used in pneumatic and fluid systems.



The Seal Group designs, manufactures and distributes industrial and commercial sealing devices and related products by providing superior quality and total customer satisfaction.

The Hydraulics Group designs, produces and markets a full spectrum of hydraulic components and systems to builders and users of industrial and mobile machinery and equipment.



The Filtration Group designs, manufactures and markets quality filtration and clarification products, providing customers with the best value, quality, technical support, and global availability.

The Automation Group is a leading supplier of pneumatic and electromechanical components and systems to automation customers worldwide.



The Instrumentation Group is a global leader in the design, manufacture and distribution of high-quality critical flow components for worldwide process instrumentation, ultra-high-purity, medical and analytical applications.

For More Information on System Protectors contact:

in the U.S. & Canada:

MRO Customers:

Parker Hannifin Corporation
Climate and Industrial Controls Aftermarket
Broadview, IL
1-800-742-2681
fax: 1-800-424-7109
www.parker.com/cicam
cicaftermarket@parker.com

OEM Customers:

(Copper Components)
Parker Hannifin Corporation
Greenfield, TN
(901) 235-3122
fax: (901) 235-2084
www.parker.com/rac

(Other System Protectors)

Parker Hannifin Corporation
Lyons, NY
(315)946-4891
fax: (315) 946-3391
www.parker.com/rac

in ASIA:

Parker Korea, Ltd.
902 Dae Heung Bldg.
648-23, Yeoksam-Dong
Kangnam-Ku,
Seoul, KOREA
82-2-561-0414
fax: 82-2-556-8187

in EUROPE:

Parker Hannifin Corporation
Cannock Office
Walkmill Lane, Bridgtown
Cannock Staffordshire
WS11 3LR ENGLAND
(44) 1543-574200
fax: (44) 1543-456171

in LATIN AMERICA:

Parker Hannifin Corporation
Pan Am Division
7400 NW 19th Street
Suite A
Miami, FL
(305) 470-8806
fax: (305) 470-8809



Parker Hannifin Corporation
World Headquarters
6035 Parkland Blvd.
Cleveland, OH 44124-4141
internet: <http://www.parker.com>

Catalog RAC-1
10/00

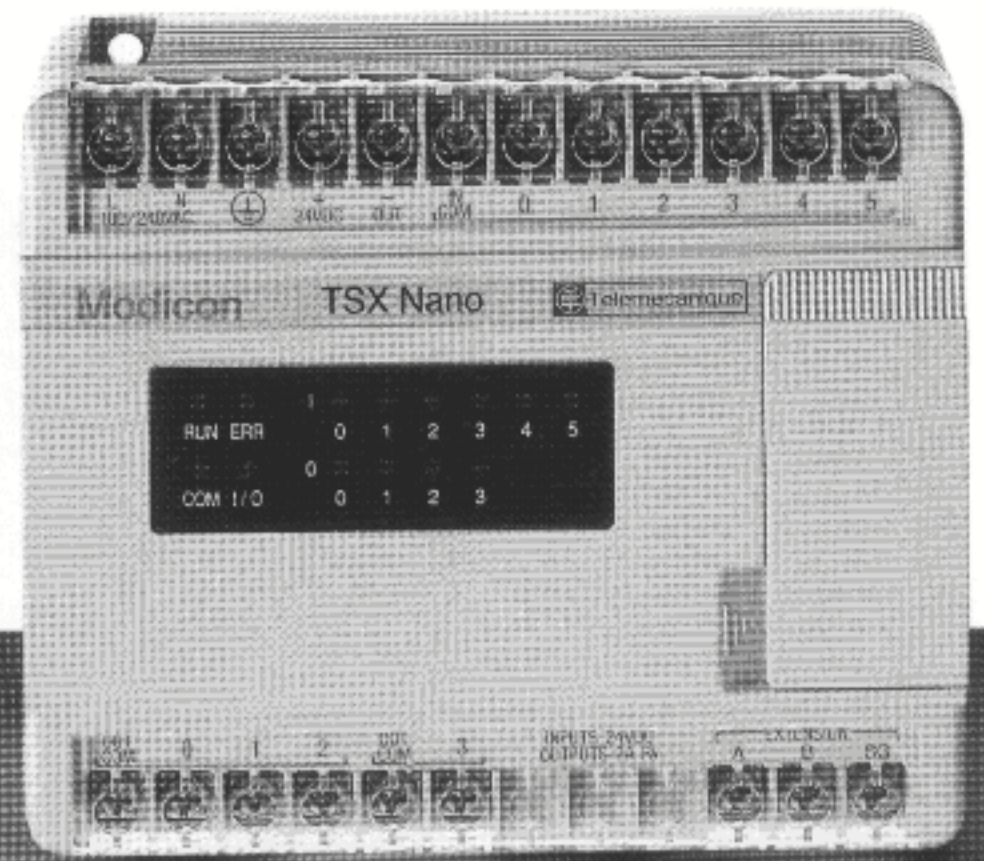

Extremely compact, broadening the field of applications

A PLC which fits anywhere

The extremely compact size of the Modicon TSX Nano means that it is equally easy to install both in shallow enclosures and directly within the framework of machines, or in mobile installations. It is easy to mount and can either be clipped onto a DIN rail or screwed vertically or horizontally onto a mounting plate.

A flexible and varied range

The Nano PLC is easily adapted to a wide variety of applications:

- 24 VDC or 100-240 VAC supply
- 24 VDC or 115 VAC inputs
- 0.5 A transistor (positive or negative logic) or 2 A relay outputs.

Since its I/O are compatible with such control system components as two or three-wire proximity sensors, photo-electric cells, or contactors, no interface is needed and setup is simplified.

The integrated analog potentiometers on the front panel make it easy to debug and run applications.

A competitive alternative

The Nano PLC is the competitive alternative to control systems which are created using:

- industrial relays, combined with control system functions (counters, timers, clock, etc)
- special purpose electronic or relay-based cards.

In many cases, the unit cost of the automated system and its development are significantly reduced, and flexibility is increased.

The Modicon TSX Nano covers all sectors of activity:

- parking lot barriers, automatic doors for controlled access
- pump management in water distribution
- air conditioning for buildings in service industries
- embroidery machines in the textile industry
- quality control in manufacturing industries
- wrapping and packaging in the food industry
- industrial washing machines, vending machines, car wash gantries and service machines
- control of doors and lighting in public transport vehicles.

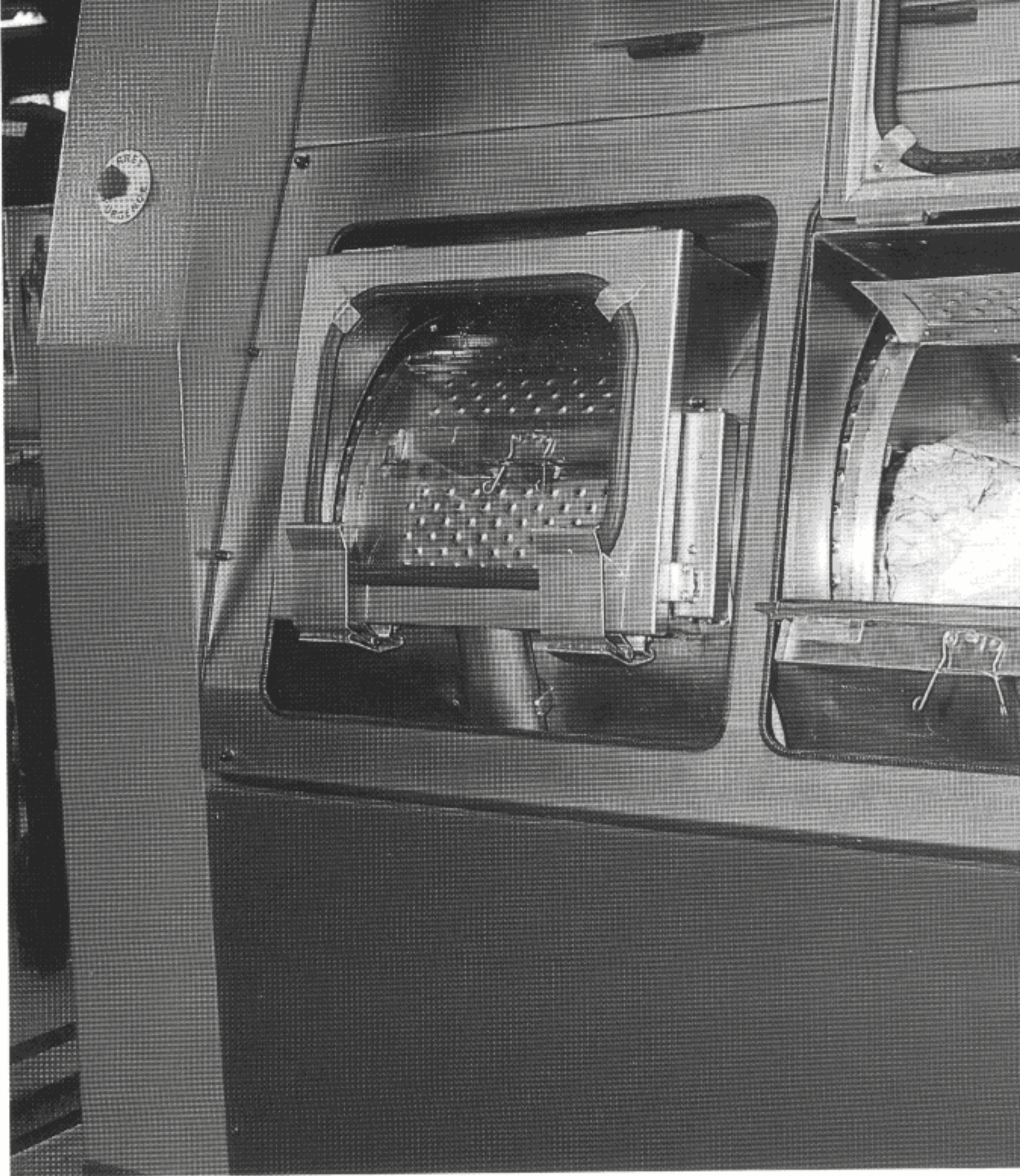

Available in three sizes, the Modicon TSX Nano provides a "just enough" solution to the requirements of applications with 10 to 48 I/O. A large number of functions (EEPROM memory, battery, real-time clock, potentiometers, etc) are built into the Nano PLC, contributing to stock optimization and thus to costs. The outstanding quality/performance ratio of the Nano PLC increases the competitiveness of both machines and equipment.

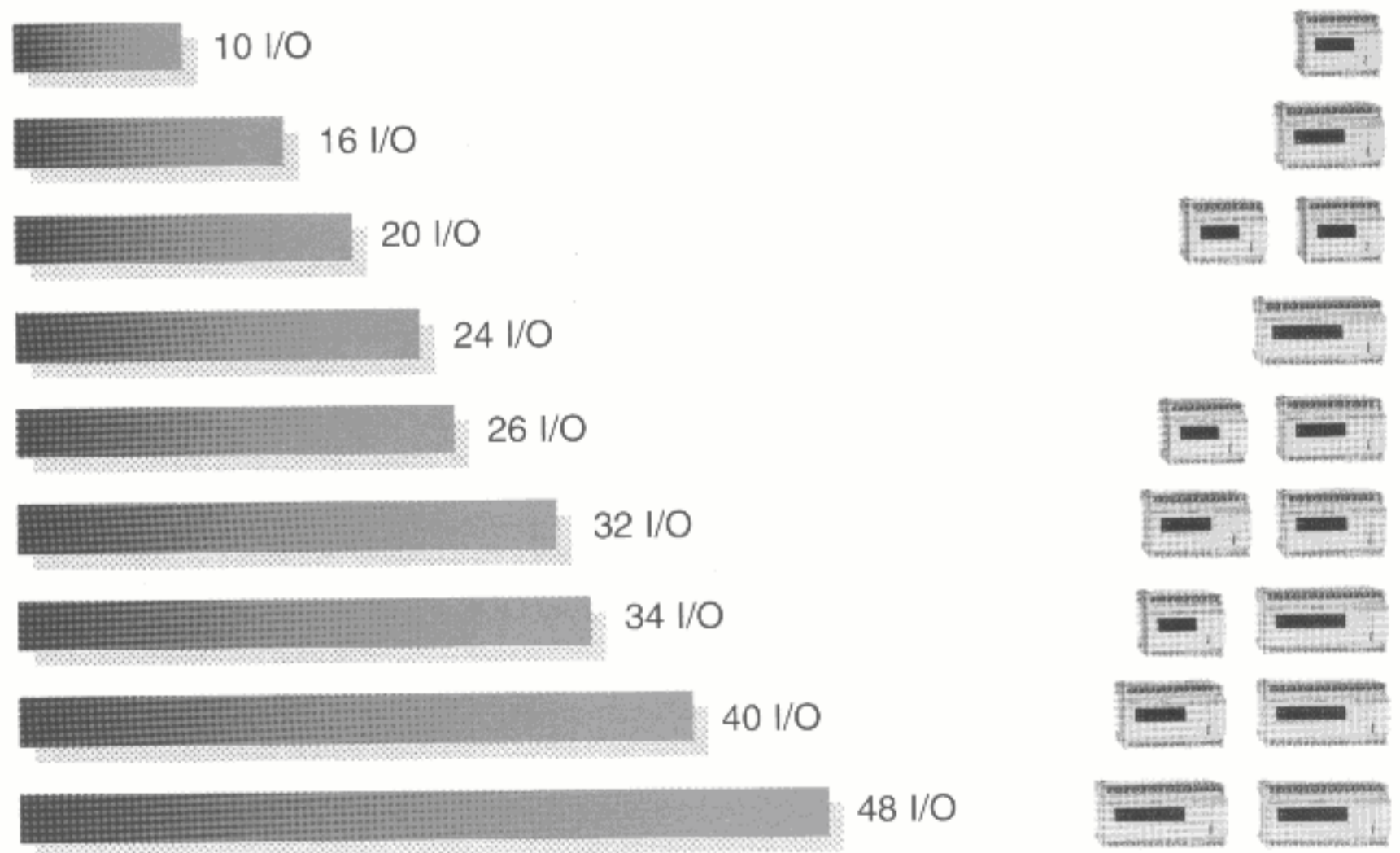

9 configurations with just 3 products.

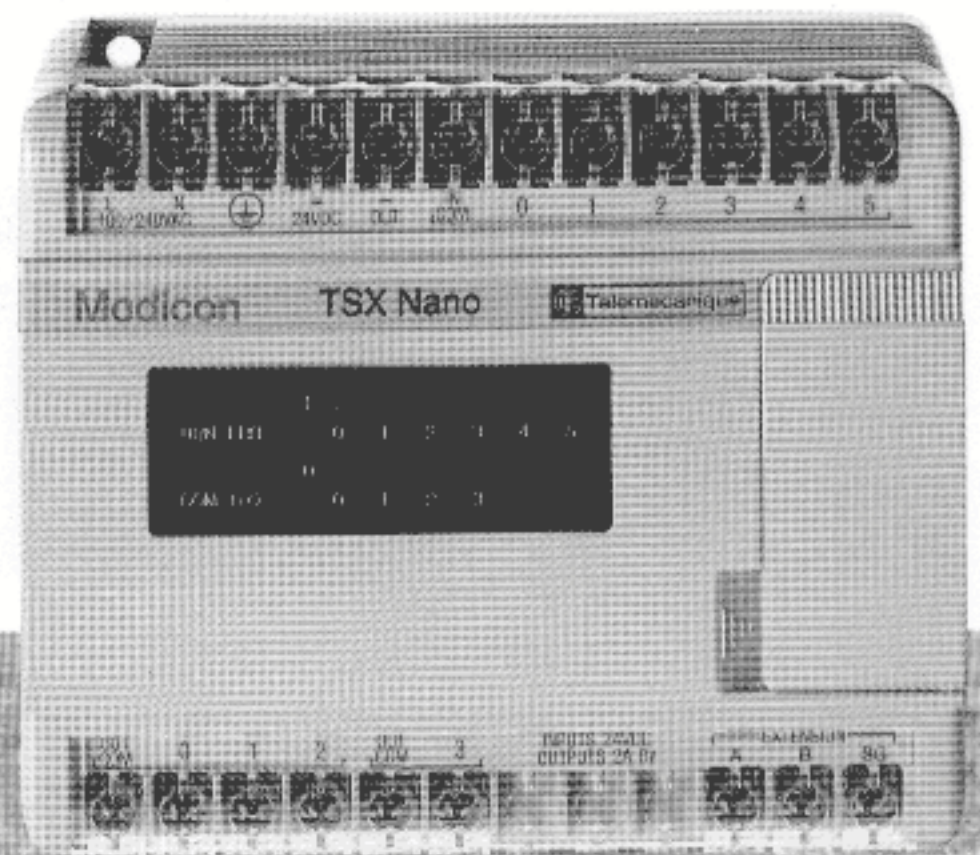

Cuts unnecessary costs.

Configurations closely matched to requirements

The three sizes of Nano PLC and the ability to connect any two of them together results in extremely flexible modularity of the number of I/O. In addition, the ratio of the number of inputs to outputs ensures that the control system engineer's needs are met without compromise. Nine configurations from 10 to 48 I/O can be created from just three standard products. Stock is thus significantly reduced and competitiveness is thereby increased.

An international product

Developed in strict adherence with international standards (IEC, EN, etc) and UL/CSA approved, the Nano PLC meets the special requirements of all the main markets in terms of both hardware and software. It is available worldwide through the international presence of the Schneider Group.

The programming tools (FTX 117 terminal and PL7-07 software for PC) as well as the documentation are available in 5 languages, endorsing the international character of the Modicon TSX Nano.











A large number of integrated functions

The Nano includes as standard:

- a backup battery for the RAM memory
- an EEPROM memory for storing programs
- a 24 VDC power supply
- adjustment potentiometers.

It also has:

- a realtime clock
- configurable I/O (fast counting, pulse output, etc)
- two serial ports for connecting third-party devices.

		UL 508 - File no. E102542
		CSA 22.2 N° 142 File no. LR66809M33
		conforms to European LV and EMC directives
Marine classification companies (certification pending)		
		Det Norske Veritas
		Germanischer Lloyd

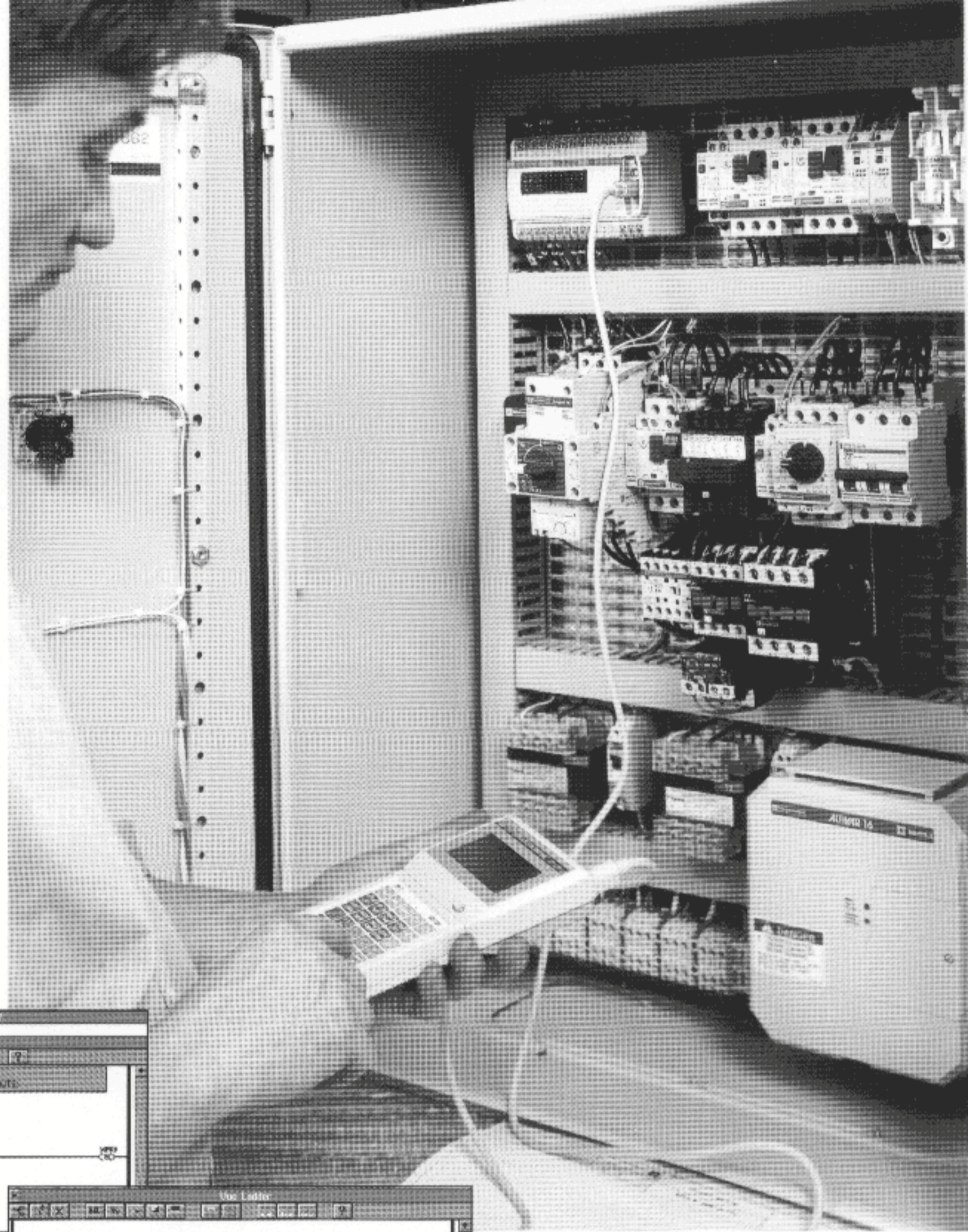

```

Edition List
-----
70 AND( TR1.DEN.0
71 OR  ARR1ERE
72 )
73 ANDH AVANCE
74 ST  ARR1ERE
---- (* SORTIE VOYANT DE SURCHARGE *)
75 LD  RI
76 OR  BOURR
77 AND( %SB
78 ORH BOURR
79 )
80 OR( DEB.MANU
81 OR  SEC.BOUR
82 )
83 ST  VOY_SUR
---- (* COMMANDE VOYANT TAPIS *)
---- (* OPTION SPECIAL POUR SAPSO *)
84 LDH TAPIS
85 AND %SB
86 ST  ARR.TAP
---- (* REGLAGE TEMPS DE DEBOURRAGE DE 0.1 A 9.9 S *)
---- (* CHARGE DECHARGEUR EST DIFFERENT SUR LE TEMPS *)
---- (* DEBOURRAGE (MECANIQUE PLUS OU MOINS LENTE) *)
87 LD  1
88 C TR_ARR.P 1= %SM12 / 364 1
  
```



Adresse	Symbol	Commentaire
%DB.2	ARR1ERE	Sortie marche avant voyant avant rapide
%DB.3	ARR.TAP	Sortie marche arriere
%DB.1	AVANCE	Bit de depart cycle de debourrage
%I2	BOURR	Entree bouton de debourrage manuel
%I2.2	BP_DEB	Contraint de securite
%I3	CU	

RTN	Type	Mod	Sec	Période	System
%TR1	TON	OUI	100 ms	00	TR1.DEN
%TR5	TON	OUI	10 ms	00	TR1.BOUR
%TR2	TON	OUI	100 ms	20	TR2
%TR3	TON	OUI	100 ms	0	TR1.ARR

Ready for use with all the most common applications, the Nano PLC can also be easily adapted to suit the special needs of any application. It is easy to program is Instruction List or Ladder language.

User-friendly tools, including a pocket programming terminal and a PC type portable industrial terminal, are readily available to help the user. The Nano PLC is easy to mount on a DIN rail or mounting plate, either vertically or horizontally, or even directly on the framework on the machine.





User-friendly, simple programming and installation

FTX 117, the easy-to-use portable terminal

The FTX 117 terminal is just as easy to use offline in the design office as on the shopfloor when connected to the PLC. Its large back-lit four-line screen and contextual data entry using a limited number of keys make it particularly user-friendly. Program entry and debugging using Instruction List language are thus easy. An application or its data can be backed up either in the internal memory of the terminal or on a memory card (credit card format) which can be transported and duplicated easily.

PL7-07 software for intuitive debugging

The diagnostics functions associated with the PL7-07 software considerably reduce application startup and maintenance times.

- program and data animation
- possibility of saving lists of variables with their values
- forcing of I/O
- troubleshooting guided by cross-references for variables
- offline programming or connected to the PLC
- modifications possible in Run
- detailed documentation and online Help.

PL7-07 software: powerful languages for every requirement

PL7-07 can be used for programming in Instruction List or Ladder language on a PC. These languages conform to standard IEC 1131-3 and can be mixed and reversed.

The instructions for Nano ensure that the user can perform fast programming, save memory space and simplify the coding of complex tasks:

- processing of words (comparisons, conversions, arithmetic, operations, etc)
- preprogrammed blocks and functions (counters, drum controllers, registers, etc)
- Grafset instructions
- subroutines and jumps
- mnemonic programming.

A full member of the TSX family

PL7-07 software uses the same programming syntax as its big brothers, PL7 Micro and Junior. Specifically designed for TSX Nano, it can be launched under Windows via an icon. In addition, a PL7-07 application can be exported to PL7 Micro and run on a Modicon TSX Micro PLC with practically no modification.

Protection of applications

Several levels of protection are available to the user to ensure the security and integrity of the programs:

- open access to the program and configuration data (supervisor level)
- access limited to variables and symbols (operator level)
- fully restricted program access (protection of expertise).

Modicon TSX Nano characteristics

PLC characteristics

Common characteristics		100 to 240 V AC		24 V DC	
Supply voltage	Nominal	V	100 to 240 - 50/60 Hz	24	
	Limit	V	85 to 264 - 47 to 63 Hz	19.2 to 30 (ripple included)	
Conforms to	IEC 1131	-	Yes	Yes	
	Power required		≤ 30 VA	≤ 14 W	
	Ground V eff.		2000/50-60 Hz	2000/50-60 Hz	
Temperature	Operating	°C	0 to +60	0 to +60	
	Storage	°C	-25 to +70	-25 to +70	
Relative humidity		%	5 to 95	5 to 95	
Input characteristics		115 V AC		24 V DC	
Nominal input values	Voltage	V	110 to 120	24	
	Current	mA	10	7	
	Sensor supply	V	24/150 mA	-	
Logic		-		Pos. or neg. depending on wiring	
Input type		-	Conforms to IEC 1131 type 1	Resistive conforms to IEC 1131 type 1	
Output characteristics		Relays	Positive logic protected transistors	Negative logic unprotected transistors	
Loads (nominal values)	Voltage	V	24 to 220, 24	24	24
	Nominal current	A	-	0.5	0.5
	Tungsten lamp	W	-	≤ 10	≤ 10
DC loads	Current	A	DC12 1-24V (0.2x10 ⁶ ops.)	0.625 for U 30 V	0.625 for U 30 V
		A	DC13 0.4-24V (1x10 ⁶ ops.)	- common for loads	+ common for loads
AC loads	AC 12 resistive current	A	AC12 1-110/220V (0.2x10 ⁶ ops.) 0.5-110/220V (2x10 ⁶ man.) 1-48V (0.5x10 ⁶ ops.) 2-24V (0.5x10 ⁶ ops.)		
	AC 15 resistive current	A	AC15 0.22-220V (1x10 ⁶ ops.) 0.45-24/48/110V (1x10 ⁶ ops.) 1-24V (0.2x10 ⁶ ops.)		

Analog module characteristics

Common characteristics					
Supply voltage	Nominal	V	DC 24		
	Limit	V	DC 21 to 30		
	Power consumption		2,5 W		
	Ground		1500 V eff.		
Conformity	IEC 1131	-	Yes		
Temperature	Operating	°C	0 to +60		
	Storage	°C	-25 to +70		
Input characteristics		0-10 V	4-20 mA	-10 to +10 V	
	Number of channels		1		
	Resolution		10 or 12 bits		
	Sampling period		125 ms for 10 bits/ 500 ms for 12 bits		
Output characteristics		0-10 V	4-20 mA	-10 to +10 V	
	Number of channels		1		
	Resolution		8 bits		
	Maximum make time		500 ms (for scale variation 0 to 100%)		

Modicon TSX Nano programming

Simple application

The example below is for a KM1 starter. After a stop, no restart is permitted for an adjustable time period (KA1). A display, H, is lit continuously while the machine is operating, and flashes during the time period in which a restart is not permitted.

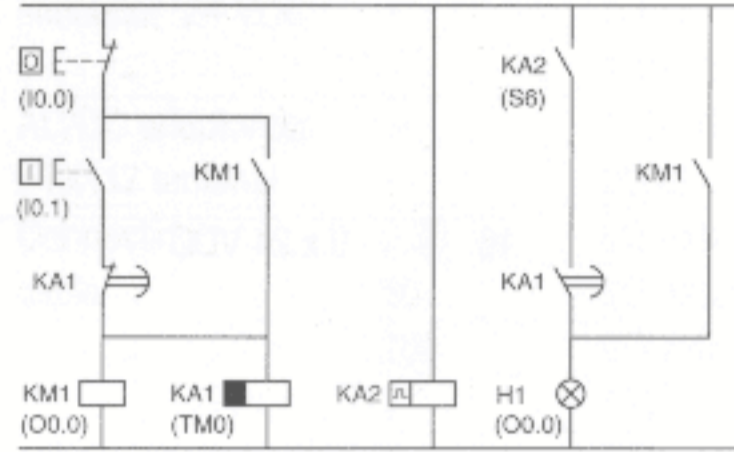

Ladder language (IEC 1131...)

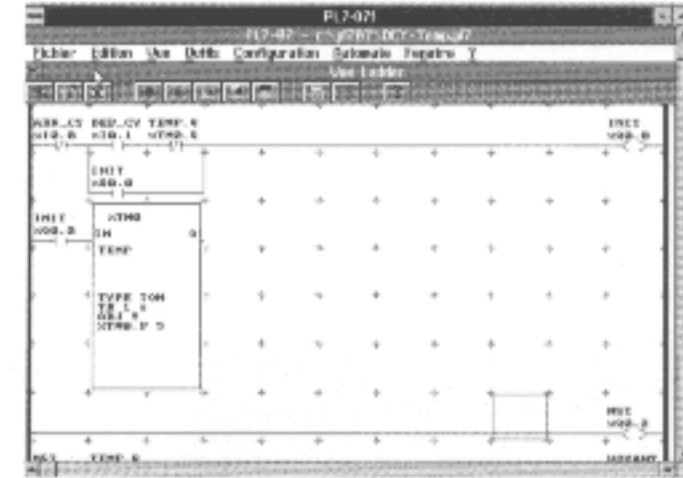

Instruction List language (IEC 1131-)

```

000 LD %I0.0
001 ANDK %I0.0
002 ANDN %TM0.0
003 OR %O0.1
004 )
005 ST %O0.1
006 IN %TM0
007 LD %S6
008 AND %TM0.0
009 OR %O0.1
010 ST %O0.0
011 END
    
```

Software characteristics

PLC characteristics

- Program memory: 1000 instructions maximum
- Protected data memory: 256 internal words, 64 constant words, 128 internal bits

Instruction List combinational instructions

- **LD, LDN, LDR, LDF** : read the state of a bit, (direct, inverse, rising and falling edges)
- ST, STN, R, S** : update and output (direct, inverse, reset, set)
- AND, ANDN, ANDR, ANDF** : binary logic AND (direct, inverse, rising and falling edges)
- OR, ORN, ORR, ORF** : binary logic OR (direct, inverse, rising and falling edges)
- AND (, OR(,)** : open and close parentheses (8 possible levels)
- XOR, XORN, XORR, XORF** : exclusive logic OR
- MPS, MRD, MPP** : instructions for processing of coils in parallel
- MCR, MCS** : master relay

Standard function blocks

- 32 Time delays : **TMi** 0 to 9999, TP/TON/TOFF type time base : 1 ms, 10 ms, 100 ms, 1 s or 1 mn
- 16 UP/Down counters : **Ci** 0 to 9999
- 4 x 16-bit LIFO or FIFO registers : **Ri**
- 4 Drum controllers : **DRI** 16 steps

Numerical instructions

- Arithmetic : **+**, **-**, **x**, **/**, **REM**, **SQRT**
- Logic : **AND**, **OR**, **XOR**, **NOT**, **INC**, **DEC**
- Shift : **SHL**, **SHR**, **SLC**, **SRC** (logic and circular)
- Conversion : **BTI**, **ITB** (BCD <-> Binary)
- Comparison : **>**, **<**, **<=**, **>=**, **=**, **<>**

Communication management

- EXCH** : Transmit/receive message instruction

- Scan : normal or periodic
- Execution time : 0,2 µs for an elementary instruction

Instruction List Grafcet instructions

- **-*i** : step (1 ≤ i ≤ 62)
- **=*i** : initial step (1 ≤ i ≤ 62)
- #i** : activates the step i,
- #** : deactivates the current step
- #Di** : deactivates a step i from another step
- =*POST** : start post-processing
- Xi** : bit associated with the step

Ladder network

- 10 contacts with 1 output per line
- N/O, N/C contacts, on edges
- Direct, inverse, SET, RESET coils
- Program jump and subroutine coils

Application-specific function blocks

- Realtime clocks : **RTCi** (0 ≤ i ≤ 15) month, day, hour, minute, with PLCs with 16 and 24 I/O

- SBRI** shift register bit (0 ≤ i ≤ 7)
- SCi** step-by-step block (0 ≤ i ≤ 7)

Program Instructions

- END, ENDC, ENDCN** : program end (conditional or unconditional)
- JMP, JMPC, JMPCN** : jump to a label (conditional or unconditional)
- SRn** : call subroutine (0 ≤ n ≤ 15)
- RET** : end subroutine

- MSG** : function block to check exchanges

Special functions

- 100 µs/3 ms/12 ms programmable filter inputs
- Configurable latching inputs (6 inputs)
- Input for PLC RUN/STOP command
- Inputs for fast counting (10 kHz), frequency meter (10 kHz) or up/down counting (1 kHz)

- Safety output on PLC fault
- PLS** pulse generator(4.9 kHz max)
- Pulse width modulation output
- PWM** (4.9 kHz max)
- 2 reflex outputs associated with fast counting

Modicon TSX Nano references



10 I/O
6 inputs/4 outputs

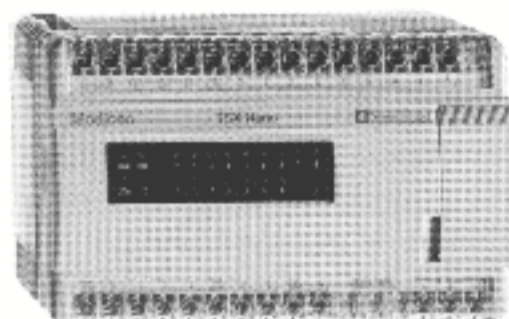

16 I/O
9 inputs/7 outputs

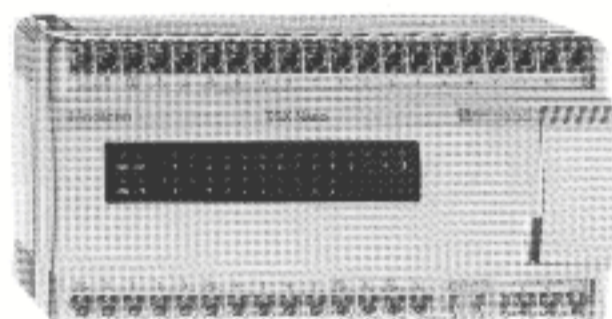

24 I/O**
14 inputs/10 outputs

* TSX 0730/0731 PLCs have additional functions compared to TSX 0720/0721 PLCs : UNI-TELWAY slave, Modbus slave, configuration of ASCII communication.

** 16 I/O (9 x 115 VAC inputs/7 outputs)

Nano programmable controllers, 24 VDC supply (1)

Number of I/O	Inputs	Relay outputs	Transistor outputs 24 V 0.5A	Reference	Weight kg
10	6 x 24 VDC	4	-	TSX 0720 1022	0.290
			-	TSX 0730 1022*	0.290
			4 protected, positive logic	TSX 0720 1012	0.270
			4 protected, positive logic	TSX 0730 1012*	0.270
16	9 x 24 VDC	7	4 negative logic	TSX 0720 1002	0.270
			-	TSX 0721 1622	0.350
			-	TSX 0731 1622*	0.350
			7 protected, positive logic	TSX 0721 1612	0.325
24	14 x 24 VDC	10	7 protected, positive logic	TSX 0731 1612*	0.325
			7 protected, positive logic	TSX 0721 1602	0.325
			7 negative logic	TSX 0721 2422	0.400
			-	TSX 0731 2422*	0.400
			10 protected, positive logic	TSX 0721 2412	0.370
			10 protected, positive logic	TSX 0731 2412*	0.370
-	TSX 0721 2402	0.370			

Nano programmable controllers, 100/240 VAC supply (1)

Number of I/O	Inputs	Relay outputs	Transistor outputs 24 V 0.5A	Reference	Weight kg
10	6 x 24 VDC	4	-	TSX 0720 1028	0.300
			-	TSX 0730 1028*	0.300
			4 negative logic	TSX 0720 1008	0.280
16	9 x 115 VAC 9 x 24 VDC	7	-	TSX 0721 1648	0.390
			-	TSX 0721 1628	0.360
			-	TSX 0731 1628*	0.360
			7 negative logic	TSX 0721 1608	0.335
24	14 x 24 VDC	10	-	TSX 0721 2428	0.410
			-	TSX 0731 2428*	0.410
			10 negative logic	TSX 0721 2408	0.380

Analog modules

Type	Nominale I/O signal range	Resolution in nominal range	Number of channels	Reference	Weight kg
Inputs	0-10 V	10-12 bits	1	TSX AEN 101	0.120
	4-20 mA	10-12 bits	1	TSX AEN 102	0.120
	-10 to + 10 V	10-12 bits	1	TSX AEN 105	0.120
Outputs	0-10 V	8 bits	1	TSX ASN 101	0.120
	4-20 mA	8 bits	1	TSX ASN 102	0.120
	-10 to + 10 V	8 bits	1	TSX ASN 105	0.120



Analog input Analog output

FTX 117 programming terminals with back-lit 4line LCD screen (1)

	Reference	Weight kg
TLX manual DM 07 117E	Nano connecting cable, length 2 m	
Supplied	Supplied	T FTX 117 071 E
		0.665

Software under DOS

Description	Support	Includes	Reference	Weight kg
Software package	FTX 417	1 3"1/2 floppy disk	TLX L PL7 07F 30 E	0.430
Reversible List/ Ladder languages	FTX 517	1 Nano connecting cable 1 installation manual		
	IBM PC, IBM PS/2, PC compatible	1 3"1/2 floppy disk 1 Nano connecting cable (2) 1 installation manual	TLX L PL7 07P 30 E	0.440



FTX 117

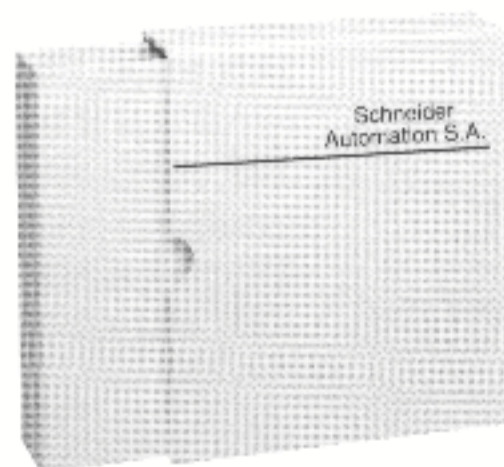

PL7-07

(1) A multilingual aide-memoire is included as standard (English, French, German, Italian and Spanish).

(2) 2 m cable equipped with a male 25-pin connector SUB-D at the PC end.

For documentation in English, German, Spanish, Italian, etc. consult your

Separate parts

Description	Length m	Use	Reference	Weight kg
Input simulator 24 VDC	-	Nano 10 I/O	TSX 07 SIM 06	0.050
	-	Nano 16 I/O	TSX 07 SIM 09	0.070
	-	Nano 24 I/O	TSX 07 SIM 14	0.080
AC/DC adaptor for FTX117 terminal	-	110/120 VAC power supply	T FTX ADC 11	0.260
	-	200/240 VAC power supply	T FTX ADC 12	0.260
Connecting cable	0.30	I/O extension	TSX CA0 003	0.015
	50	I/O extension or Nano/Nano	TSX STC 050	1.710
	200	I/O extension or Nano/Nano	TSX STC 200	6.790
	2	FTX 117 <-> Nano	T FTX CB1 020	0.100
	5	FTX 117 <-> Nano	T FTX CB1 050	0.190
	2	FTX 417/517 <-> Nano	T FTX CBF 020	0.180
	2	PC compatible <-> Nano	TSX PCU 1030	0.200
	5	Nano <-> XBT/CCX 17	XBT-Z 968	0.230
	2,50	Modem cable	TSX PCX 1130	0.248
Memory card	-	EEPROM 32 K words	T FTX REM 3216	0.025
	-	Protected RAM 32 K words	T FTX RSM 3216	0.030
	-	Protected RAM 128 K words	T FTX RSM 12816	0.030
	-	Battery for RAM memory card	TSX BAT M01	
Self-teach cases		1 Nano (16 I/O), 1 input simulator, 1 FTX 117 with cable	TSX SDC 07 30 117	0.950
		1 Nano (16 I/O), 1 input simulator, 1 PL7-07 software with cable for FTX 417/517	TSX SDC 07 30 DSF	0.600
		1 Nano (16 I/O), 1 input simulator, 1 PL7-07 software with cable for PC compatible	TSX SDC 07 30 DSP	0.600
Documentation (in English)		Nano/FTX 117 user's manual	TLX DM 07 117 E	0.265
		Nano/PC compatible user's manual	TLX DM 07 DS E	0.320
		Nano/FTX 117 self-teach manual	TLX DT FTX 117 30E	0.280
		Nano/PC compatible self-teach manual	TLX DT PL7 07 30E	0.280

TSX Nano

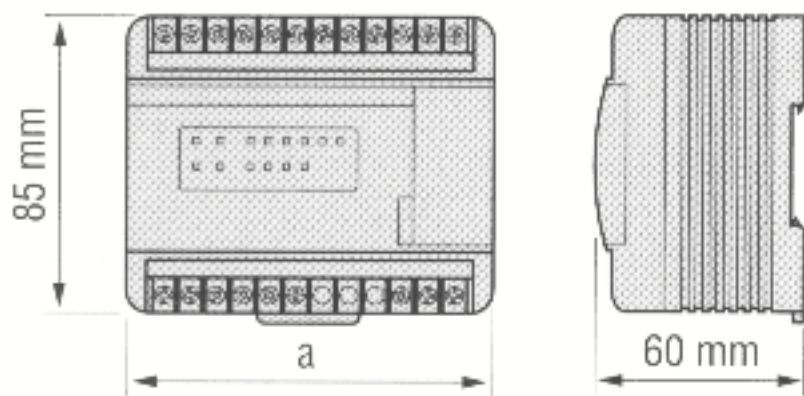

Dimensions, mounting

TSX A.N...

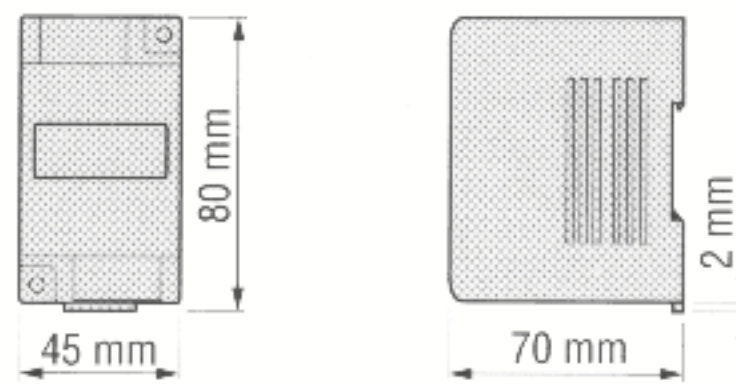

FTX 117...

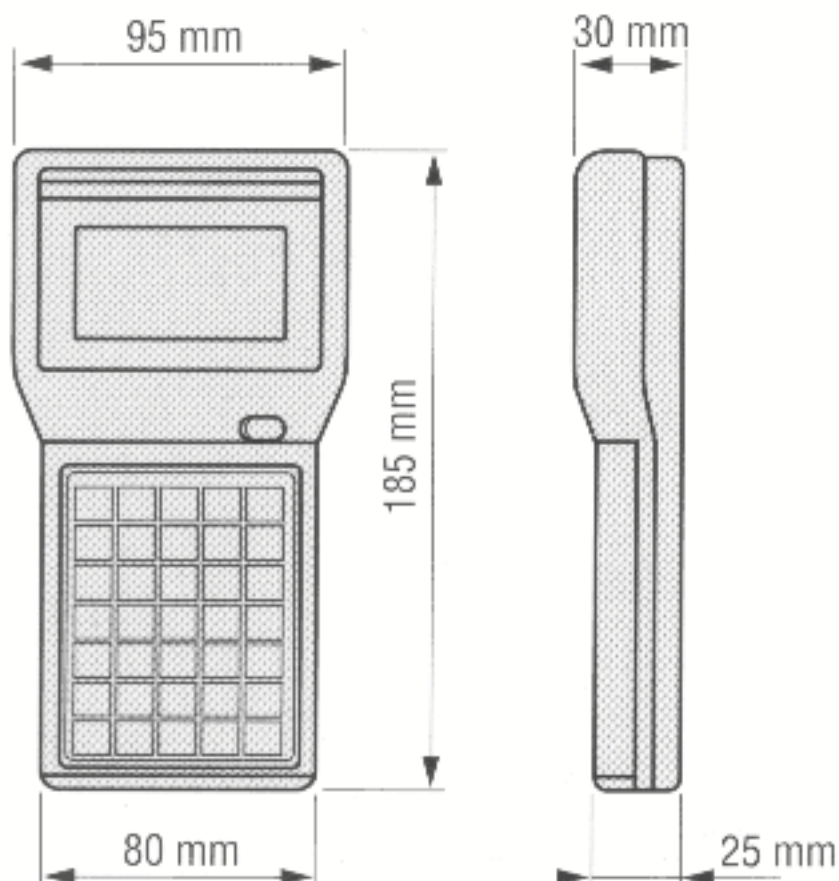

TSX Nano

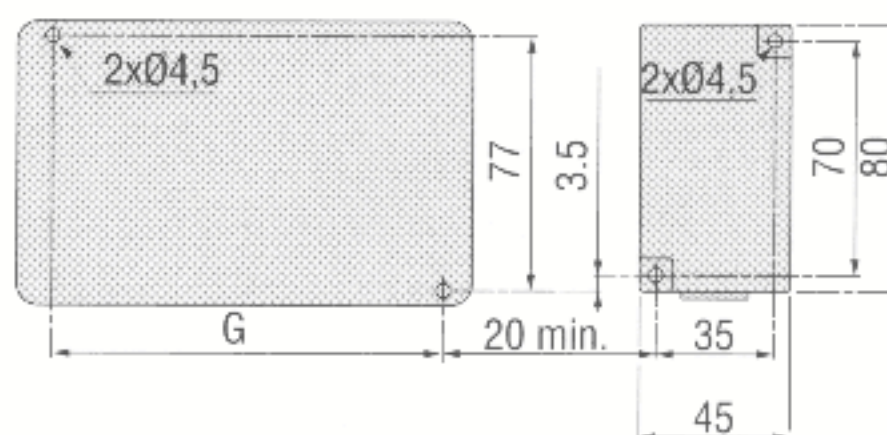

	a	G
TSX Nano 10 I/O	105	86
TSX Nano 16 I/O	135	116
TSX Nano 16 I/O 115V	165	146
TSX Nano 24 I/O	165	146



Refrigeration & Air Conditioning Control Valves

for R22 - R134a - R404A - R507

Catalog 611F/USA
January 2000



FLO-CON
Refrigerating
Specialties

Parker Refrigerating Specialties Commercial Control Valves - Selection Guide

Valve Type	Valve Description	Typical Applications	Reference Bulletin
A8A, A81, A82	Inlet, or Upstream Pressure Regulator	Evaporator Pressure Control Discharge Pressure Regulator Liquid Drain Regulator Defrost Relief Regulator	Bulletin 25-94B
A8AS, A81S, A82S	Inlet Pressure Regulator w/ Electric Shut- Off Feature	Evaporator Pressure Control	
A8AB, A81B, A82B	Inlet Pressure Regulator w/ Electric Bypass Feature	Discharge Pressure Regulator	
A8AL, A81L, A82L A4AL	Differential Pressure Regulator	Discharge Pressure Regulator Liquid Feed Regulator	
A8ABL, A81BL, A82BL A4ABL	Differential Pressure Regulator w/ Electric Bypass Feature	Discharge Pressure Regulator Liquid Feed Regulator	
A8AOE, A81OE, A82OE	Outlet Pressure Regulator	Crankcase Pressure Regulator Hot Gas Bypass Regulator Receiver Pressure Regulator	Bulletin 25-94B
A8AOES, A81OES, A82OES	Outlet Pressure Regulator w/ Electric Shut- Off Feature	Hot Gas Bypass Regulator	
PORT, PORT-II	Inlet, or Upstream Pressure Regulator	Evaporator Pressure Control	Bulletins 26-01 & 26-02
(S)PORT, (S)PORT-II	Inlet Pressure Regulator w/ Electric Shut-Off Feature	Evaporator Pressure Control	
(S)PORT-B, (S)PORT-II-B	Inlet Pressure Regulator w/ Electric Shut-Off and Bypass Features	Evaporator Pressure Control	
A9	Outlet Pressure Regulator	Receiver Pressure Regulator	Bulletin 25-95D
A9E	Outlet Pressure Regulator w/ External Equalizer	Hot Gas Bypass Regulator	
A9S	Outlet Pressure Regulator w/ Electric Shut-Off Feature	Receiver Pressure Regulator	
A9SE	Outlet Pressure Regulator w/ Electric Shut-Off Feature, and External Equalizer	Hot Gas Bypass Regulator	
CK4A	Flanged In Line Check Valve	Liquid Drain Check Valve Condenser Bypass Check Valve	Bulletin 50-16C
SC1, SC2	Suction Line Solenoid Valves	Control (open/close) of Suction Lines for Defrost	Bulletin 33-00
S81, S82	General Purpose Refrigeration Solenoid Valve	Control (open/close) of Suction Lines Hot Gas Feed Solenoid Liquid Supply Solenoid	Bulletin 32-00

Table of Contents

Product Overview 4

(S)PORT - (S)PORT-II Evaporator Pressure Regulators 6

A8, (S)PORT, and SC Suction Capacities 8

A8 Pressure Regulators 16

A9 Pressure Regulators 18

CK4 Check Valve 20

CK4 Liquid Drain Capacities 22

Condenser Pressure Controls 26

A8 Liquid Drain Capacities 28

A8 Discharge Capacities 32

CK4A Hot Gas Discharge Capacities 40

Condenser Bypass Capacities 48

Hot Gas Bypass 56

Hot Gas Bypass Capacities 58

Discharge Regulators for Supermarket Applications 62

Crankcase Pressure Regulators 63

SC Suction Solenoid Valves 64

S81 / S82 Solenoid Valves 66

Temperature Pressure Chart 68

Reference Material 72

Offer of Sale 74

Product Overview

With more than 30 years of commercial refrigeration control valve design and manufacturing experience, the Parker Refrigerating Specialties product line has evolved to include a wide variety of regulators, solenoid valves, and in-line check valves designed for precise and reliable control in both supermarket and field built halocarbon systems. Included in this expanded family of refrigeration components are high capacity pilot operated regulators and solenoid valves in extended port and connection size combinations. The highest capacity non-flanged regulators and solenoid valves available in the industry are included in this unique combination of control valves. Considering their application in larger systems, one control valve may be used in place of a competitor's parallel valve combination in some instances.

Parker Refrigerating Specialties commercial pilot operated regulators are modular by design, and are superior to direct operated valves in their ability to maintain a precise control of set point, despite changes in load. With a parabolic plug design as a standard feature throughout this line of regulators, a linear relationship exists between the main valve opening and the valve's capacity. The result is a steady set point and precise control, even at varying or low flow conditions.

As an added benefit, Parker Refrigerating Specialties pilot operated solenoid valves in the SC and S8 series utilize the same bodies, cartridges, and solenoid coil assemblies as their (S)PORT and A8 regulator counterparts. In many instances, capacities can be changed by simply changing cartridges, a feature common throughout both lines of regulators and solenoid valves.

Parker Refrigerating Specialties product bulletins are also available for all valve types covered throughout this 611E condensed catalog. Product bulletins cover a variety of details such as dimensions, cutaway views, and specific information related to valve operation, which is not included within the context of this catalog. Product bulletin numbers are referenced in the selection guide matrix on page 2 and are readily available upon request.

A8 Pressure Regulators

Initially introduced as the A7, the current A8 pressure regulator is designed with flexibility in mind, covering both high and low side applications in commercial refrigeration systems. A dual range spring, standard in all A8 regulators (with the exception of the differential version), allows the valve to control at any set point within a 10" Hg to 400 psi (250mm Hg to 27.6 bar) pressure range. Three body sizes define the A8 line. The A8A is the smallest of the three, the A81 covers the mid-range applications, and the A82 is the largest. Along with the standard A8 inlet pressure regulator, optional variations include inlet regulators with electric shut off features (A8AS, A81S, A82S) and wide opening or bypass features (A8_B). In addition, outlet pressure regulators (A8_OE), outlet regulators with electric shut-off features (A8_OES), differential pressure regulators (A8_L), and differential regulators with wide opening features (A8_BL) round out the product line. Eight different "port" sizes (or capacity cartridges) are available in the A8 family of regulators with connection sizes ranging from 7/8" (22mm) up to 2-5/8" (66mm). All A8 regulators are ductile iron bodied valves with brazed copper couplings. Valve cartridges are also made of ductile iron. A water resistant class "H" coil enclosed in a general purpose coil housing is supplied as standard with any A8 regulator version. Solenoid coils can be supplied either with twin leads or with DIN connectors.



(S)PORT / (S)PORT II Pressure Regulators

The (S)PORT and (S)PORT-II pressure regulators are a unique line of valves designed specifically for evaporator pressure control in commercial supermarket applications. All (S)PORT regulators are designed to control in a pressure range of 10" Hg to 120 psig (250mm Hg to 8.3 bar). The original (S)PORT, introduced several years ago, continues to be manufactured with a ductile iron body and cartridge assembly. The (S)PORT-II, a more recent addition to the line, is made of completely corrosion resistant materials including aluminum bronze bodies and cartridge assemblies, and stainless steel bolts and adjusting stems. (S)PORT regulators are available in three common versions typically applied on low side applications: A standard upstream pressure regulator, or PORT, a regulator combined with an electric shut-off feature, or (S)PORT, and a unique combina-



tion of electric shut and bypass feature, the (S)PORT-B. The (S)PORT version is typically applied on a refrigeration circuit utilizing hot gas for defrosting purposes, while the (S)PORT-B offers the same capability in addition to a wide opening, or bypass feature, for quick pull down during start up or after a circuit's hot gas defrost period has been terminated. A water resistant class F coil and open frame coil housing is standard on the (S)PORT regulator line. Solenoid coils with DIN connectors can also be supplied.

S8 Solenoid Valves

S8 solenoid valves are flexible by design, suitable for discharge gas applications or as a liquid feed valve. S8 solenoid valves can also be applied on a low side (suction line) application. If (S)PORT pressure regulators are being considered, however, on a supermarket rack system for example, the Refrigerating Specialties "SC" solenoid valve would be a better option (see description below) as suction shut-off devices. Overall, the design of the S8 solenoid valve with regards to its major components, complements that of the A8 regulator. That is, the valve bodies, cartridge assemblies, solenoid operators, and solenoid coils are identical to those used on the A8 regulator line. The same class "H" coil and general purpose coil housing which are standard throughout the A8 regulator line are supplied with the S8 solenoid. Along with the A8 line of regulators, solenoid coils with DIN connectors are also available.



SC Solenoid Valves

The "SC" line of solenoid valves were designed to complement (S)PORT pressure regulators in both appearance and construction. Components such as valve bodies, cartridges, solenoid operators, and solenoid coils are interchangeable between the SC solenoid and (S)PORT regulator lines of valves. Like the (S)PORT regulator, the SC solenoid is available with either ductile iron materials (both body and cartridge) or corrosion resistant aluminum bronze materials. With the (S)PORT regulator and SC solenoid combination, any suction line control requirement can be satisfied while maintaining reliable performance and common appearance. The SC line of solenoids utilizes the same water resistant class F coil and open frame coil housing which is standard with the (S)PORT line of regulators.



A9 Pressure Regulators

A9 outlet pressure regulators utilize a compact design unique to the Refrigerating Specialties line of regulators, and are applied most typically as hot gas bypass or receiver pressure control valves. Four port sizes ranging from 3/8" (9mm) through 1-1/8" (28mm) are available. Utilizing a pilot operated design for stable control of set point, the A9E is typically used as a hot gas bypass regulator. The A9E regulator, when used in a hot gas bypass application, is externally equalized to suction pressure, or the pressure being controlled. Through years of reliable performance, it has become a standard on a variety of OEM equipment where precise suction pressure control is required for stable system operation. The A9, an internally equalized regulator which senses and controls immediate downstream pressure, is typically applied as a receiver pressure control valve for those systems using regulators for condenser pressure control on air cooled condensers.



CK4A In Line Check Valves

CK4A in line check valves are versatile spring closing disc check valves, used for most hot gas and liquid line applications. The CK4 series of check valves are a flanged family of check valves, utilizing a gasketed refrigeration style tongue-and-groove ODS flange for commercial applications. Eight port sizes are available ranging from 1/2" (13mm) through 4" (100mm). Up through and including the 2" port size valve, three different ODS connection sizes are available for each port size valve to accommodate a reduced capacity valve in larger lines. All valves are made to tight seat leakage specifications, utilizing a lapped metal-to-metal seat design. The pressure drop required to open the valve fully is about .75 psi. Because of its spring closing design, CK4 check valves can be installed in both vertical and horizontal pipe lines.



(S)PORT - (S)PORT-II Evaporator Pressure Regulators

Features

- Highest capacity commercial regulator in the industry.
- Sweat-in-place without disassembly.
- Interchangeable capacity cartridges.
- Low pressure drop.
- Manual opening stem.
- Variations include electric shut-off along with bypass and shut-off feature.
- (S)PORT-II with corrosion resistant aluminum bronze construction.
- All stainless steel bolts, stem, locking nut, piston and plug.
- Dual voltage 208/240/60 Hz coil.



Specifications

- Design pressure (M.R.P.): 450 psig (31.0 bar)
- Minimum fluid temperature -40°F (-40°C)
- Operating range: 10" Hg to 120 psig (250 mm Hg to 8.3 bar)
- UL listed (except 50 Hz versions), file SA5473
- CSA certified, file LR20991-14

Standard Voltages

- 120V/60Hz, 110V/50Hz
- 208V/240V/60Hz, 220V/50Hz
- 240V/50Hz
- 240V/60Hz, 220V/50Hz (DIN)
- 240V/50Hz (DIN)

Valve Nomenclature

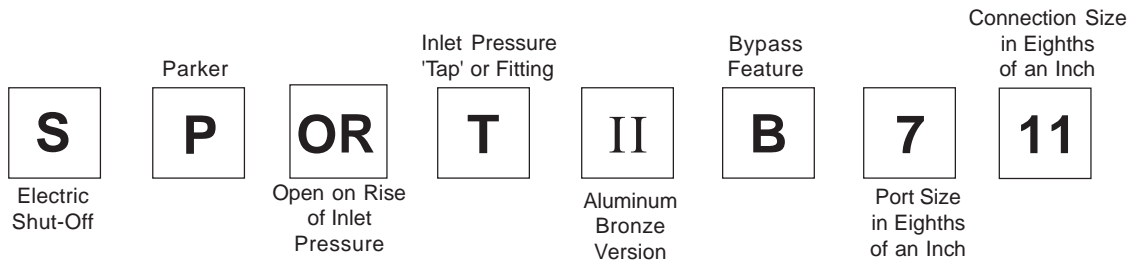

(S)PORT Port/Connection Size Combinations

Type	Port Size	Connection Sizes Available
(S)PORT or (S)PORT-II	03 (3/8", 9mm)	07, 09, 11, 13, 17 (7/8" /22mm, 1-1/8" /28mm, 1-3/8" /35mm, 1-5/8" /42mm, 2-1/8" /54mm)
	05 (5/8" 15mm)	07, 09, 11, 13, 17 (7/8" /22mm, 1-1/8" /28mm, 1-3/8" /35mm, 1-5/8" /42mm, 2-1/8" /54mm)
	07 (7/8", 22mm)	07, 09, 11, 13, 17 (7/8" /22mm, 1-1/8" /28mm, 1-3/8" /35mm, 1-5/8" /42mm, 2-1/8" /54mm)
	09 (1-1/8", 28mm)	07, 09, 11, 13, 17 (7/8" /22mm, 1-1/8" /28mm, 1-3/8" /35mm, 1-5/8" /42mm, 2-1/8" /54mm)
	11 (1-3/8", 35mm)	09, 11, 13, 17 (1-1/8" /28mm, 1-3/8" /35mm, 1-5/8" /42mm, 2-1/8" /54mm)
(S)PORT	13 (1-5/8", 42mm)	13, 17, 21 (1-5/8" /42mm, 2-1/8" /54mm, 2-5/8" /66mm)
	17 (2-1/8", 54mm)	17, 21 (2-1/8" /54mm, 2-5/8" /66mm)
	21 (2-5/8", 66mm)	21 (2-5/8", 66mm)

**(NOTE: (S)PORT-II regulators have same port/ connection combinations as standard (S)PORT regulators but are not available in the 13, 17, or 21 port size versions).*

Description: Unlike other Parker Refrigerating Specialties regulators, (S)PORT regulators utilize a unique numbering system identifying port & connection size values in eighths of an inch (see previous page). For example, a 7/8" port size by 1-1/8" connection size valve would be identified as a (S)PORT 07-09, with the valves port size being the first numerical value in the description (in eighths of an inch), and the connection size being the second value. All (S)PORT cartridges are externally stamped with the plug or port size using this same numbering system for field identification purposes.

(S)PORT evaporator pressure regulators are available in two versions, each with their own distinct material characteristics; the original (S)PORT, and the (S)PORT-II. The original (S)PORT utilizes a ductile iron body with brazed copper couplings along with a ductile iron cartridge assembly. The original (S)PORT is available in eight port sizes ranging from a 3/8" (03) to 2-5/8" (21) and with connection sizes up to 2-5/8" (21). A 1/4" SAE flare access fitting is standard on the upstream side of the valve's cartridge assembly. An open frame, class F leaded coil is provided as standard with all (S)PORT regulators. A class H coil with DIN connector is also available with certain voltages.

The (S)PORT-II, a more recent introduction, is made completely with corrosion resistant materials. Both the body and cartridge are an aluminum-bronze material, with the adapter and bonnet being aluminum. In addition, stainless steel bonnet bolts and adjusting stems are standard on all (S)PORT-II regulators. In contrast to the original (S)PORT, five port sizes are offered with the (S)PORT-II style of regulator, ranging from 3/8" (03) to 1-3/8" (11). The same open-frame coil housing which is standard on the (S)PORT is supplied with the (S)PORT-II. The access fitting on the (S)PORT-II is located on the upstream side of the valve body, and positioned to easily connect a gauge fitting for servicing. The (S)PORT-II design specifically targets the rigorous application of a commercial evaporator pressure regulator - particularly those applications with hot gas defrost circuits. The corrosion resistant design of the (S)PORT-II is capable of withstanding the cooling and heating cycles to which these types of regulators are continually exposed.

All (S)PORT regulators are designed to be applied as a low side (evaporator) pressure regulator only. They are capable of being set to control pressures within a 10" to 120 psig (250mm Hg through 8.3 bar) range. For high side regulator applications, the Refrigerating Specialties A8 regulator should be considered.

Variations: PORT or PORT-II: Standard Inlet pressure regulator. (S)PORT or (S)PORT-II: Inlet pressure regulator with an electric shut-off feature. (S)PORT-B or

(S)PORT-II-B. Inlet pressure regulator with an electric shut-off and electric wide opening, (or bypass) feature.

Installation: (S)PORT regulators use a spring loaded solenoid plunger design which assists the plunger in closing off tightly against the solenoid pilot seat regardless of position or orientation. The regulator can therefore be installed in either a horizontal or vertical pipe line regardless of the type of (S)PORT valve being installed (i.e. with or without a pilot solenoid).

When brazing in line, typically a wet cloth wrapped around the valve body is recommended to dissipate heat. **If a valve is disassembled prior to installation, always have the correct gasket/ O-ring kit available for reassembly.** The internal cartridge-to-body O-ring will need to be replaced prior to reassembly.

Adjustment: Adjustment of a regulators set point requires that the pressure being controlled be monitored by an accurate pressure gauge. Turning the valves adjusting screw clockwise (into the bonnet) compresses the range spring and subsequently raises the valves set point. Conversely, turning the adjusting stem counter-clockwise will decrease the valves set point. Adjusting the set point of a (S)PORT regulator must be made with the solenoid energized, and the manual opening stem turned in. The inlet side solenoid only is required to be energized to adjust the set point on a (S)PORT-B. Depending on system design and system conditions, the pressure gauge may reflect some delay before a change in a regulator's set point actually results in a change in the pressure being maintained.

Electrical: All (S)PORT regulator versions utilize a molded water resistant class "F" solenoid coil with open frame housing as standard. A class "H" DIN coil is also available with certain voltages. Coils are designed to operate with line voltage from 85% to 110% of rated coil voltage. Operating with a coil voltage above or below these limits may result in coil burnout. Also, operating with a coil voltage below this limit will result in lowering the valves maximum opening pressure differential, or MOPD. Power consumption during normal operation will be 10 watts or less. The 208/240/60 Hz wide voltage range coil used on all (S)PORT regulators is rated at 280 MOPD. All other coils are rated at 300 MOPD.

Ordering Guide: Specify valve type (PORT, (S)PORT, (S)PORT-II, etc.), port and connection size in eighths of an inch (port size indicated first), and voltage, if applicable.

A8, (S)PORT & SC Suction Capacities (Tons)

R22

Evap Temp °F	Pres Drop	03	05	07	09	11	13	17	21
Evap Pres. psig	psi	3/8" 9 mm	5/8" 15 mm	7/8" 22 mm	1-1/8" 28 mm	1-3/8" 35 mm	1-5/8" 42 mm	2-1/8" 54 mm	2-5/8" 66 mm
50° F 84 psig	1	0.74	1.88	2.65	3.37	5.97	8.90	15.66	20.06
	3	1.26	3.20	4.53	5.77	10.20	15.22	26.77	34.25
	5	1.59	4.08	5.77	7.36	12.99	19.41	34.09	43.60
	10	2.15	5.55	7.91	10.11	17.75	26.58	46.55	59.45
40° F 68.5 psig	1	0.67	1.70	2.40	3.06	5.42	8.08	14.22	18.20
	3	1.14	2.90	4.10	5.23	9.24	13.79	24.24	31.01
	5	1.44	3.68	5.22	6.66	11.73	17.53	30.79	39.36
	10	1.92	4.98	7.11	9.09	15.92	23.87	41.76	53.30
30° F 54.9 psig	1	0.61	1.54	2.17	2.77	4.90	7.31	12.86	16.46
	3	1.02	2.61	3.70	4.72	8.33	12.43	21.85	27.95
	5	1.29	3.31	4.69	5.99	10.55	15.77	27.67	35.36
	10	1.70	4.43	6.34	8.12	14.19	21.30	37.21	47.46
20° F 43.0 psig	1	0.55	1.39	1.96	2.49	4.41	6.58	11.57	14.82
	3	0.92	2.34	3.32	4.23	7.47	11.16	19.59	25.06
	5	1.15	2.95	4.19	5.36	9.42	14.10	24.71	31.57
	10	1.49	3.91	5.62	7.20	12.54	18.85	32.88	41.89
10° F 32.7 psig	1	0.49	1.24	1.75	2.23	3.95	5.89	10.37	13.27
	3	0.81	2.09	2.96	3.78	6.66	9.95	17.46	22.33
	5	1.01	2.61	3.72	4.76	8.35	12.51	21.91	27.98
	10	1.29	3.41	4.92	6.33	10.96	16.51	28.74	36.57
0° F 23.9 psig	1	0.43	1.11	1.56	1.99	3.52	5.25	9.24	11.82
	3	0.72	1.85	2.62	3.35	5.89	8.81	15.46	19.76
	5	0.88	2.30	3.28	4.20	7.35	11.01	19.27	24.58
	10	1.09	2.93	4.27	5.49	9.46	14.29	24.79	31.50
-10° F 16.4 psig	1	0.38	0.98	1.38	1.76	3.12	4.65	8.18	10.47
	3	0.63	1.62	2.31	2.95	5.18	7.75	13.58	17.34
	5	0.76	1.99	2.86	3.67	6.39	9.60	16.77	21.38
	10	0.91	2.47	3.64	4.70	8.02	12.17	21.02	26.64
-20° F 10.1 psig	1	0.34	0.86	1.22	1.55	2.74	4.09	7.19	9.20
	3	0.54	1.41	2.01	2.57	4.50	6.75	11.81	15.08
	5	0.65	1.71	2.47	3.17	5.50	8.27	14.41	18.34
	10	0.73	2.04	3.04	3.94	6.65	10.14	17.41	21.98
-30° F 4.8 psig	1	0.29	0.75	1.06	1.36	2.39	3.57	6.28	8.03
	3	0.46	1.21	1.73	2.22	3.87	5.81	10.15	12.95
	5	0.54	1.44	2.09	2.70	4.65	7.02	12.18	15.47
	10	0.56	1.61	2.46	3.22	5.32	8.19	13.93	17.49
-40° F 0.5 psig	1	0.25	0.65	0.92	1.18	2.07	3.10	5.43	6.95
	3	0.39	1.02	1.47	1.89	3.28	4.94	8.60	10.95
	5	0.43	1.18	1.74	2.25	3.84	5.83	10.07	12.75
	10	0.43	1.23	1.90	2.52	4.06	6.31	10.63	13.34

Capacities are based on 100° F liquid, 10° F superheat at valve inlet, and are maximum for the conditions listed. For each 10° F liquid is below 100° F, INCREASE capacity values by 4%. (*Sizing charts are also for Crankcase Pressure Regulators in sizes to 2 1/8 port only.)

NOTE: Due to conditions encountered with refrigeration circuits utilizing hot gas for defrosting purposes, a maximum pressure drop of 3 psi should be used in the regulator selection process. If a pressure drop of more than 3 psi is considered, the regulator could become restrictive after the termination of a defrost cycle, thereby requiring an extended pull down period. The shaded areas of the suction tables designate regulator capacities above a 3 psi pressure drop, and should not be considered for these types of systems.



A8, (S)PORT & SC Suction Capacities (Kilowatts)

R22

Evap Temp °C	Pres Drop	03	05	07	09	11	13	17	21
Evap Pres. Bar	bar	3/8"	5/8"	7/8"	1-1/8"	1-3/8"	1-5/8"	2-1/8"	2-5/8"
		9 mm	15 mm	22 mm	28 mm	35 mm	42 mm	54 mm	66 mm
10° C 5.8 bar	0.07	2.57	6.53	9.20	11.71	20.76	30.95	54.47	69.74
	0.2	4.27	10.88	15.37	19.59	34.65	51.70	90.91	116.34
	0.4	5.88	15.07	21.35	27.25	48.04	71.78	126.04	161.16
	0.8	7.86	20.39	29.11	37.24	65.23	97.77	171.09	218.37
5° C 4.8 bar	0.07	2.36	5.98	8.43	10.74	19.03	28.37	49.93	63.93
	0.2	3.90	9.95	14.07	17.93	31.70	47.30	83.16	106.41
	0.4	5.35	13.73	19.48	24.87	43.80	65.49	114.92	146.90
	0.8	7.08	18.44	26.39	33.79	59.07	88.62	154.91	197.59
0° C 4 bar	0.07	2.15	5.46	7.70	9.81	17.38	25.91	45.59	58.37
	0.2	3.55	9.06	12.82	16.34	28.87	43.10	75.74	96.90
	0.4	4.84	12.45	17.69	22.59	39.74	59.44	104.25	133.21
	0.8	6.32	16.56	23.78	30.48	53.13	79.80	139.31	177.56
-5° C 3.2 bar	0.07	1.96	4.97	7.01	8.93	15.82	23.59	41.51	53.14
	0.2	3.22	8.22	11.64	14.84	26.20	39.13	68.74	87.93
	0.4	4.35	11.23	15.99	20.43	35.89	53.72	94.14	120.25
	0.8	5.60	14.77	21.29	27.32	47.46	71.41	124.44	158.45
-10° C 2.6 bar	0.07	1.77	4.51	6.36	8.11	14.35	21.41	37.66	48.21
	0.2	2.90	7.43	10.53	13.43	23.68	35.38	62.14	79.46
	0.4	3.89	10.08	14.38	18.39	32.24	48.30	84.56	107.96
	0.8	4.90	13.05	18.91	24.31	42.05	63.40	110.23	140.19
-15° C 1.98 bar	0.07	1.60	4.07	5.75	7.32	12.96	19.33	34.01	43.53
	0.2	2.60	6.67	9.47	12.08	21.29	31.82	55.84	71.39
	0.4	3.45	8.98	12.84	16.44	28.75	43.12	75.40	96.19
	0.8	4.23	11.40	16.62	21.42	36.83	55.68	96.53	122.56
-20° C 1.46 bar	0.07	1.44	3.66	5.17	6.59	11.65	17.38	30.57	39.12
	0.2	2.32	5.96	8.46	10.81	19.02	28.45	49.89	63.75
	0.4	3.03	7.93	11.38	14.59	25.43	38.20	66.68	84.99
	0.8	3.58	9.80	14.43	18.65	31.81	48.27	83.35	105.59
-25° C 1.0 bar	0.07	1.28	3.27	4.62	5.89	10.42	15.55	27.34	34.98
	0.2	2.05	5.28	7.52	9.61	16.88	25.27	44.27	56.54
	0.4	2.62	6.93	9.99	12.83	22.27	33.52	58.39	74.34
	0.8	2.95	8.27	12.32	15.98	26.98	41.15	70.66	89.23
-30° C 0.63 bar	0.07	1.14	2.91	4.11	5.24	9.26	13.83	24.30	31.09
	0.2	1.79	4.64	6.63	8.48	14.86	22.27	38.96	49.73
	0.4	2.24	5.97	8.67	11.16	19.26	29.07	50.49	64.18
	0.8	2.35	6.78	10.28	13.42	22.31	34.27	58.37	73.39
-40° C 0.04 bar	0.07	0.88	2.25	3.19	4.07	7.18	10.73	18.83	24.07
	0.2	1.32	3.47	5.00	6.42	11.16	16.78	29.26	37.26
	0.4	1.51	4.19	6.22	8.07	13.66	20.80	35.78	45.23
	0.8	1.49	4.24	6.50	8.56	13.99	21.61	36.59	45.92

Capacities are based on 40° C liquid, 5° C superheat at valve inlet, and are maximum for the conditions listed. For each 5° C liquid is below 40° C, INCREASE capacity values by 7%. (*Sizing charts are also for Crankcase Pressure Regulators in sizes to 2 1/8 port only.)

NOTE: Due to conditions encountered with refrigeration circuits utilizing hot gas for defrosting purposes, a maximum pressure drop of .20 bar should be used in the regulator selection process. If a pressure drop of more than .20 bar is considered, the regulator could become restrictive after the termination of a defrost cycle, thereby requiring an extended pull down period. The shaded areas of the suction tables designate regulator capacities above a .20 bar pressure drop, and should not be considered for these types of systems.

A8, (S)PORT & SC Suction Capacities Tons)

R134a

Evap Temp °F	Pres Drop	03 3/8"	05 5/8"	07 7/8"	09 1-1/8"	11 1-3/8"	13 1-5/8"	17 2-1/8"	21 2-5/8"
Evap Pres. psig	psi	9 mm	15 mm	22 mm	28 mm	35 mm	42 mm	54 mm	66 mm
50° F 84 psig	1	0.58	1.47	2.07	2.64	4.67	6.96	12.25	15.68
	3	0.97	2.48	3.51	4.48	7.90	11.80	20.73	26.51
	5	1.21	3.12	4.44	5.67	9.96	14.91	26.14	33.39
	10	1.57	4.13	5.94	7.61	13.25	19.92	34.74	44.25
40° F 68.5 psig	1	0.51	1.31	1.84	2.35	4.16	6.20	10.91	13.97
	3	0.86	2.20	3.11	3.97	7.00	10.47	18.38	23.49
	5	1.06	2.75	3.92	5.01	8.79	13.16	23.05	29.43
	10	1.35	3.58	5.18	6.65	11.52	17.36	30.20	38.43
30° F 54.9 psig	1	0.46	1.16	1.64	2.08	3.69	5.50	9.67	12.38
	3	0.75	1.93	2.75	3.51	6.17	9.23	16.18	20.68
	5	0.92	2.40	3.43	4.39	7.69	11.53	20.16	25.72
	10	1.14	3.06	4.46	5.74	9.89	14.95	25.93	32.93
20° F 43.0 psig	1	0.40	1.02	1.44	1.84	3.25	4.85	8.52	10.90
	3	0.65	1.69	2.40	3.07	5.39	8.07	14.14	18.07
	5	0.79	2.08	2.98	3.82	6.66	10.00	17.47	22.27
	10	0.94	2.58	3.79	4.89	8.36	12.68	21.90	27.75
10° F 32.7 psig	1	0.35	0.89	1.26	1.61	2.84	4.25	7.46	9.55
	3	0.56	1.46	2.08	2.67	4.67	7.00	12.25	15.64
	5	0.67	1.77	2.56	3.29	5.70	8.58	14.95	19.04
	10	0.75	2.12	3.15	4.09	6.91	10.54	18.09	22.85
0° F 23.9 psig	1	0.30	0.78	1.10	1.40	2.47	3.69	6.49	8.30
	3	0.48	1.25	1.79	2.29	4.00	6.01	10.50	13.39
	5	0.56	1.49	2.17	2.79	4.81	7.26	12.61	16.02
	10	0.57	1.68	2.55	3.34	5.53	8.51	14.48	18.19
-10° F 16.4 psig	1	0.26	0.67	0.95	1.21	2.13	3.19	5.59	7.15
	3	0.40	1.05	1.52	1.95	3.39	5.09	8.88	11.30
	5	0.45	1.23	1.80	2.33	3.98	6.03	10.41	13.20
	10	0.46	1.27	1.98	2.62	4.22	6.58	11.03	13.74

Capacities are based on 100° F liquid, 10° F superheat at valve inlet, and are maximum for the conditions listed. For each 10° F liquid is below 100 ° F, INCREASE capacity values by 4%. (*Sizing charts are also for Crankcase Pressure Regulators in sizes to 2 1/8 port only.)

NOTE: Due to conditions encountered with refrigeration circuits utilizing hot gas for defrosting purposes, a maximum pressure drop of 3 psi should be used in the regulator selection process. If a pressure drop of more than 3 psi is considered, the regulator could become restrictive after the termination of a defrost cycle, thereby requiring an extended pull down period. The shaded areas of the suction tables designate regulator capacities above a 3 psi pressure drop, and should not be considered for these types of systems.

A8, (S)PORT & SC Suction Capacities (Kilowatts)

R134a

Evap Temp °C Evap Pres. Bar	Pres Drop bar	03	05	07	09	11	13	17	21
		3/8" 9 mm	5/8" 15 mm	7/8" 22 mm	1-1/8" 28 mm	1-3/8" 35 mm	1-5/8" 42 mm	2-1/8" 54 mm	2-5/8" 66 mm
10° C 3.13 bar	0.07	2.05	5.03	7.25	9.30	16.50	24.60	43.20	55.20
	0.2	3.38	8.73	12.10	15.60	27.60	41.30	72.50	92.60
	0.35	4.31	10.90	15.70	20.20	35.80	53.50	93.80	119.90
	0.7	5.54	14.50	20.90	26.90	47.50	71.00	124.60	159.20
5° C 2.48 bar	0.07	1.85	4.54	6.54	8.42	14.90	22.20	39.00	49.90
	0.2	3.02	7.56	10.90	14.00	24.80	37.10	65.10	83.10
	0.35	3.82	9.73	14.00	18.10	31.90	47.70	83.70	106.90
	0.7	4.82	12.80	18.40	23.70	41.80	62.50	109.70	140.20
0° C 1.92 bar	0.07	1.65	4.07	5.87	7.56	13.40	20.00	35.00	44.80
	0.2	2.68	6.75	9.73	12.50	22.10	33.10	58.00	74.20
	0.35	3.36	8.62	12.40	16.00	28.30	42.20	74.10	94.70
	0.7	4.13	11.10	16.00	20.60	36.40	54.40	95.50	122.00
-5° C 1.42 bar	0.07	1.47	3.64	5.24	6.75	11.90	17.80	31.30	40.00
	0.2	2.36	5.98	8.61	11.10	19.60	29.30	51.40	65.70
	0.35	2.92	7.56	10.90	14.00	24.80	37.10	65.00	83.10
	0.7	3.49	9.54	13.80	17.70	31.30	46.80	82.10	104.90
-10° C .993 bar	0.07	1.30	3.23	4.65	5.99	10.60	15.80	27.80	35.50
	0.2	2.06	5.25	7.57	9.75	17.20	25.80	45.20	57.70
	0.35	2.50	6.57	9.47	12.20	21.50	32.20	56.50	72.20
	0.7	2.88	8.08	11.60	15.00	26.50	39.60	69.50	88.80
-15° C .625 bar	0.07	1.15	2.85	4.10	5.28	9.34	14.00	24.50	31.30
	0.2	1.78	4.57	6.59	8.49	15.00	22.40	39.30	50.30
	0.35	2.12	5.64	8.12	10.50	18.50	27.60	48.50	61.90
	0.7	2.32	6.71	9.68	12.50	22.00	32.90	57.70	73.80
-20° C .3149 bar	0.07	1.00	2.50	3.60	4.63	8.19	12.20	21.50	27.40
	0.2	1.52	3.94	5.68	7.31	12.90	19.30	33.90	43.30
	0.35	1.76	4.77	6.87	8.85	15.60	23.40	41.00	52.40
	0.7	1.87	5.46	7.88	10.10	17.90	26.80	47.00	60.00

Capacities are based on 40° C liquid, 5° C superheat at valve inlet, and are maximum for the conditions listed. For each 5° C liquid is below 40° C, INCREASE capacity values by 7%. (*Sizing charts are also for Crankcase Pressure Regulators in sizes to 2 1/8 port only.)

NOTE: Due to conditions encountered with refrigeration circuits utilizing hot gas for defrosting purposes, a maximum pressure drop of .20 bar should be used in the regulator selection process. If a pressure drop of more than .20 bar is considered, the regulator could become restrictive after the termination of a defrost cycle, thereby requiring an extended pull down period. The shaded areas of the suction tables designate regulator capacities above a .20 bar pressure drop, and should not be considered for these types of systems.

A8, (S)PORT & SC Suction Capacities Tons) R404a

Evap Temp °F	Pres Drop	03	05	07	09	11	13	17	21
Evap Pres. psig	psi	3/8"	5/8"	7/8"	1-1/8"	1-3/8"	1-5/8"	2-1/8"	2-5/8"
		9 mm	15 mm	22 mm	28 mm	35 mm	42 mm	54 mm	66 mm
50° F 84 psig	1	0.63	1.60	2.26	2.87	5.09	7.59	13.36	17.10
	3	1.08	2.74	3.87	4.93	8.71	13.00	22.87	29.26
	5	1.37	3.49	4.94	6.30	11.12	16.60	29.17	37.32
	10	1.85	4.78	6.80	8.68	15.26	22.84	40.03	51.14
40° F 68.5 psig	1	0.56	1.43	2.02	2.57	4.55	6.79	11.95	15.30
	3	0.96	2.44	3.45	4.40	7.78	11.61	20.42	26.13
	5	1.22	3.11	4.40	5.62	9.91	14.80	25.99	33.24
	10	1.64	4.23	6.03	7.71	13.52	20.25	35.47	45.29
30° F 54.9 psig	1	0.50	1.27	1.80	2.29	4.05	6.04	10.64	13.62
	3	0.85	2.17	3.07	3.91	6.91	10.31	18.13	23.19
	5	1.07	2.75	3.90	4.98	8.77	13.11	23.02	29.43
	10	1.43	3.72	5.31	6.79	11.89	17.83	31.19	39.80
20° F 43.0 psig	1	0.45	1.13	1.59	2.03	3.59	5.36	9.43	12.07
	3	0.75	1.92	2.71	3.46	6.10	9.11	16.01	20.48
	5	0.94	2.42	3.44	4.39	7.72	11.55	20.26	25.90
	10	1.24	3.24	4.64	5.94	10.38	15.58	27.21	34.70
10° F 32.7 psig	1	0.39	0.99	1.40	1.79	3.16	4.72	8.30	10.63
	3	0.66	1.68	2.38	3.03	5.35	8.00	14.04	17.96
	5	0.82	2.11	3.00	3.84	6.75	10.09	17.69	22.61
	10	1.06	2.79	4.01	5.15	8.96	13.47	23.49	29.92
0° F 23.9 psig	1	0.34	0.87	1.23	1.57	2.78	4.14	7.28	9.32
	3	0.57	1.46	2.08	2.65	4.67	6.98	12.25	15.66
	5	0.71	1.83	2.61	3.34	5.85	8.77	15.35	19.60
	10	0.90	2.38	3.44	4.42	7.66	11.54	20.07	25.53
-10° F 16.4 psig	1	0.30	0.76	1.07	1.37	2.42	3.61	6.34	8.11
	3	0.49	1.27	1.80	2.30	4.04	6.04	10.60	13.54
	5	0.60	1.57	2.25	2.87	5.03	7.54	13.18	16.81
	10	0.74	1.99	2.91	3.74	6.44	9.73	16.87	21.42
-20° F 10.1 psig	1	0.26	0.66	0.93	1.18	2.09	3.12	5.48	7.01
	3	0.42	1.08	1.54	1.97	3.46	5.18	9.08	11.59
	5	0.51	1.33	1.91	2.45	4.26	6.41	11.18	14.25
	10	0.60	1.64	2.41	3.12	5.31	8.06	13.91	17.61
-30° F 4.8 psig	1	0.22	0.56	0.80	1.01	1.79	2.67	4.70	6.01
	3	0.35	0.92	1.31	1.67	2.93	4.39	7.68	9.81
	5	0.42	1.11	1.60	2.06	3.56	5.37	9.34	11.88
	10	0.46	1.30	1.95	2.53	4.26	6.51	11.15	14.06
-40° F 0.5 psig	1	0.19	0.48	0.68	0.86	1.52	2.27	3.99	5.10
	3	0.29	0.76	1.09	1.40	2.45	3.67	6.41	8.17
	5	0.34	0.90	1.32	1.70	2.92	4.41	7.64	9.70
	10	0.34	0.99	1.52	1.99	3.27	5.06	8.56	10.73

Capacities are based on 100° F liquid, 10° F superheat at valve inlet, and are maximum for the conditions listed. For each 10° F liquid is below 100 ° F, INCREASE capacity values by 4%. (*Sizing charts are also for Crankcase Pressure Regulators in sizes to 2 1/8 port only.)

NOTE: Due to conditions encountered with refrigeration circuits utilizing hot gas for defrosting purposes, a maximum pressure drop of 3 psi should be used in the regulator selection process. If a pressure drop of more than 3 psi is considered, the regulator could become restrictive after the termination of a defrost cycle, thereby requiring an extended pull down period. The shaded areas of the suction tables designate regulator capacities above a 3 psi pressure drop, and should not be considered for these types of systems.

A8, (S)PORT & SC Suction Capacities (Kilowatts)

R404a

Evap Temp °F	Pres Drop	03	05	07	09	11	13	17	21
Evap Pres. psig	bar	3/8"	5/8"	7/8"	1-1/8"	1-3/8"	1-5/8"	2-1/8"	2-5/8"
		9 mm	15 mm	22 mm	28 mm	35 mm	42 mm	54 mm	66 mm
10° C	0.07	2.15	5.46	7.70	9.80	17.37	25.90	45.59	58.37
5.8 bar	0.2	3.59	9.13	12.88	16.42	29.05	43.33	76.22	97.55
	0.4	4.95	12.67	17.94	22.89	40.38	60.32	105.95	135.51
	0.8	6.67	17.25	24.58	31.43	55.15	82.59	144.66	184.72
5° C	0.07	1.94	4.93	6.96	8.86	15.69	23.40	41.18	52.73
4.8 bar	0.2	3.23	8.23	11.62	14.81	26.19	39.08	68.73	87.95
	0.4	4.44	11.39	16.14	20.60	36.32	54.27	95.28	121.83
	0.8	5.94	15.41	22.00	28.15	49.31	73.90	129.32	165.06
0° C	0.07	1.75	4.44	6.27	7.98	14.14	21.08	37.10	47.50
4 bar	0.2	2.90	7.39	10.45	13.32	23.55	35.14	61.78	79.05
	0.4	3.97	10.20	14.47	18.47	32.54	48.64	85.35	109.11
	0.8	5.25	13.69	19.60	25.09	43.86	65.80	115.01	146.70
-5° C	0.07	1.57	3.99	5.62	7.16	12.68	18.91	33.28	42.60
3.2 bar	0.2	2.59	6.61	9.35	11.92	21.07	31.45	55.27	70.71
	0.4	3.53	9.08	12.90	16.48	28.99	43.36	76.05	97.17
	0.8	4.61	12.07	17.34	22.22	38.73	58.18	101.55	129.43
-10° C	0.07	1.40	3.56	5.02	6.39	11.32	16.88	29.70	38.03
2.6 bar	0.2	2.30	5.88	8.33	10.62	18.75	27.99	49.18	62.90
	0.4	3.11	8.03	11.43	14.61	25.66	38.42	67.32	85.98
	0.8	3.99	10.55	15.21	19.52	33.90	51.01	88.88	113.16
-15° C	0.07	1.24	3.16	4.46	5.68	10.06	15.00	26.40	33.79
1.98 bar	0.2	2.03	5.20	7.37	9.41	16.59	24.79	43.53	55.66
	0.4	2.72	7.06	10.07	12.88	22.57	33.82	59.20	75.57
	0.8	3.42	9.12	13.22	17.00	29.39	44.32	77.03	97.95
-20° C	0.07	1.10	2.80	3.95	5.03	8.91	13.29	23.38	29.92
1.46 bar	0.2	1.79	4.58	6.50	8.30	14.62	21.86	38.36	49.03
	0.4	2.36	6.16	8.81	11.28	19.72	29.59	51.73	65.99
	0.8	2.89	7.80	11.38	14.67	25.20	38.12	66.04	83.84
-25° C	0.07	0.97	2.46	3.48	4.43	7.84	11.69	20.56	26.31
1.0 bar	0.2	1.56	4.00	5.69	7.27	12.78	19.12	33.52	42.83
	0.4	2.03	5.32	7.64	9.79	17.06	25.63	44.73	57.00
	0.8	2.38	6.55	9.65	12.47	21.25	32.27	55.68	70.51
-30° C	0.07	0.84	2.15	3.04	3.88	6.85	10.22	17.97	22.99
0.63 bar	0.2	1.34	3.47	4.94	6.31	11.08	16.59	29.06	37.11
	0.4	1.71	4.54	6.55	8.41	14.58	21.96	38.24	48.67
	0.8	1.91	5.37	8.03	10.42	17.56	26.81	45.98	58.03
-40° C	0.07	0.63	1.60	2.27	2.90	5.11	7.64	13.42	17.16
0.04 bar	0.2	0.96	2.52	3.61	4.62	8.07	12.11	21.16	26.97
	0.4	1.15	3.13	4.60	5.94	10.15	15.39	26.60	33.72
	0.8	1.14	3.24	5.07	6.70	10.81	16.85	28.25	35.19

Capacities are based on 40° C liquid, 5° C superheat at valve inlet, and are maximum for the conditions listed. For each 5° C liquid is below 40° C, INCREASE capacity values by 7%. (*Sizing charts are also for Crankcase Pressure Regulators in sizes to 2 1/8 port only.)

NOTE: Due to conditions encountered with refrigeration circuits utilizing hot gas for defrosting purposes, a maximum pressure drop of .20 bar should be used in the regulator selection process. If a pressure drop of more than .20 bar is considered, the regulator could become restrictive after the termination of a defrost cycle, thereby requiring an extended pull down period. The shaded areas of the suction tables designate regulator capacities above a .20 bar pressure drop, and should not be considered for these types of systems.

A8, (S)PORT & SC Suction Capacities Tons)

R507

Evap Temp °F	Pres Drop	03	05	07	09	11	13	17	21
		3/8"	5/8"	7/8"	1-1/8"	1-3/8"	1-5/8"	2-1/8"	2-5/8"
Evap Pres. psig	psi	9 mm	15 mm	22 mm	28 mm	35 mm	42 mm	54 mm	66 mm
50° F 84 psig	1	0.66	1.66	2.34	2.98	5.29	7.88	13.88	17.77
	3	1.12	2.85	4.02	5.12	9.06	13.51	23.77	30.42
	5	1.42	3.63	5.13	6.55	11.56	17.26	30.34	38.81
	10	1.93	4.97	7.07	9.04	15.89	23.77	41.67	53.24
40° F 68.5 psig	1	0.59	1.49	2.10	2.68	4.74	7.07	12.44	15.93
	3	1.00	2.55	3.60	4.58	8.11	12.09	21.27	27.22
	5	1.27	3.24	4.59	5.85	10.33	15.42	27.09	34.65
	10	1.71	4.41	6.29	8.04	14.11	21.13	37.01	47.26
30° F 54.9 psig	1	0.52	1.33	1.88	2.39	4.23	6.31	11.11	14.23
	3	0.89	2.27	3.21	4.09	7.22	10.78	18.94	24.24
	5	1.12	2.88	4.08	5.20	9.17	13.71	24.07	30.77
	10	1.50	3.89	5.56	7.11	12.45	18.67	32.66	41.69
20° F 43.0 psig	1	0.47	1.18	1.67	2.13	3.76	5.61	9.88	12.64
	3	0.79	2.01	2.84	3.62	6.40	9.55	16.79	21.47
	5	0.99	2.54	3.60	4.60	8.10	12.11	21.26	27.17
	10	1.31	3.40	4.88	6.24	10.91	16.37	28.60	36.48
10° F 32.7 psig	1	0.41	1.05	1.48	1.88	3.33	4.96	8.73	11.18
	3	0.69	1.77	2.50	3.19	5.64	8.42	14.78	18.91
	5	0.86	2.23	3.17	4.04	7.11	10.63	18.65	23.82
	10	1.12	2.95	4.24	5.44	9.46	14.22	24.81	31.62
0° F 23.9 psig	1	0.36	0.92	1.30	1.65	2.93	4.36	7.68	9.83
	3	0.60	1.55	2.19	2.80	4.93	7.37	12.93	16.54
	5	0.75	1.94	2.76	3.53	6.19	9.26	16.23	20.72
	10	0.95	2.52	3.65	4.68	8.12	12.23	21.28	27.08
-10° F 16.4 psig	1	0.32	0.80	1.13	1.44	2.56	3.81	6.71	8.58
	3	0.52	1.34	1.90	2.43	4.28	6.40	11.22	14.34
	5	0.64	1.67	2.38	3.05	5.33	7.99	13.98	17.84
	10	0.79	2.13	3.09	3.98	6.86	10.37	17.98	22.84
-20° F 10.1 psig	1	0.27	0.70	0.98	1.25	2.22	3.31	5.81	7.44
	3	0.45	1.15	1.64	2.09	3.68	5.51	9.65	12.32
	5	0.54	1.42	2.03	2.60	4.54	6.82	11.91	15.18
	10	0.64	1.75	2.58	3.33	5.69	8.63	14.91	18.89
-30° F 4.8 psig	1	0.23	0.60	0.85	1.08	1.91	2.85	5.00	6.40
	3	0.38	0.98	1.40	1.79	3.13	4.69	8.20	10.47
	5	0.45	1.19	1.71	2.20	3.81	5.74	9.99	12.72
	10	0.50	1.41	2.10	2.73	4.60	7.01	12.03	15.19
-40° F 0.5 psig	1	0.20	0.51	0.72	0.92	1.62	2.43	4.26	5.45
	3	0.31	0.82	1.17	1.50	2.62	3.94	6.88	8.77
	5	0.36	0.97	1.42	1.82	3.14	4.74	8.23	10.45
	10	0.37	1.08	1.65	2.16	3.57	5.50	9.34	11.72

Capacities are based on 100° F liquid, 10° F superheat at valve inlet, and are maximum for the conditions listed. For each 10° F liquid is below 100° F, INCREASE capacity values by 4%. (*Sizing charts are also for Crankcase Pressure Regulators in sizes to 2 1/8 port only.)

NOTE: Due to conditions encountered with refrigeration circuits utilizing hot gas for defrosting purposes, a maximum pressure drop of 3 psi should be used in the regulator selection process. If a pressure drop of more than 3 psi is considered, the regulator could become restrictive after the termination of a defrost cycle, thereby requiring an extended pull down period. The shaded areas of the suction tables designate regulator capacities above a 3 psi pressure drop, and should not be considered for these types of systems.

A8, (S)PORT & SC Suction Capacities (Kilowatts)

R507

Evap Temp °C	Pres Drop	03	05	07	09	11	13	17	21
Evap Pres. Bar	bar	3/8"	5/8"	7/8"	1-1/8"	1-3/8"	1-5/8"	2-1/8"	2-5/8"
		9 mm	15 mm	22 mm	28 mm	35 mm	42 mm	54 mm	66 mm
10° C 5.8 bar	0.07	2.25	5.70	8.03	10.23	18.13	27.03	47.58	60.92
	0.2	3.74	9.53	13.45	17.14	30.32	45.24	79.57	101.83
	0.4	5.18	13.24	18.74	23.90	42.18	63.00	110.67	141.55
	0.8	6.98	18.04	25.70	32.85	57.67	86.35	151.27	193.19
5° C 4.8 bar	0.07	2.03	5.16	7.28	9.27	16.42	24.48	43.09	55.17
	0.2	3.38	8.61	12.16	15.50	27.42	40.91	71.94	92.07
	0.4	4.66	11.93	16.91	21.57	38.04	56.84	99.80	127.62
	0.8	6.24	16.17	23.07	29.51	51.72	77.50	135.65	173.16
0° C 4 bar	0.07	1.84	4.66	6.57	8.37	14.83	22.11	38.91	49.82
	0.2	3.04	7.76	10.97	13.98	24.71	36.88	64.83	82.96
	0.4	4.17	10.71	15.20	19.40	34.17	51.08	89.65	114.60
	0.8	5.53	14.41	20.61	26.39	46.14	69.21	121.01	154.38
-5° C 3.2 bar	0.07	1.65	4.19	5.91	7.53	13.34	19.89	35.00	44.81
	0.2	2.73	6.96	9.84	12.55	22.17	33.10	58.18	74.43
	0.4	3.72	9.57	13.59	17.36	30.54	45.68	80.13	102.40
	0.8	4.87	12.75	18.30	23.45	40.89	61.42	107.24	136.70
-10° C 2.6 bar	0.07	1.48	3.76	5.30	6.75	11.95	17.82	31.36	40.14
	0.2	2.43	6.22	8.80	11.22	19.80	29.57	51.96	66.46
	0.4	3.29	8.50	12.09	15.45	27.15	40.63	71.21	90.97
	0.8	4.25	11.19	16.12	20.69	35.96	54.09	94.28	120.08
-15° C 1.98 bar	0.07	1.32	3.35	4.73	6.02	10.66	15.89	27.96	35.80
	0.2	2.16	5.52	7.82	9.97	17.59	26.28	46.16	59.03
	0.4	2.89	7.50	10.69	13.67	23.97	35.91	62.87	80.27
	0.8	3.66	9.73	14.08	18.10	31.32	47.21	82.10	104.44
-20° C 1.46 bar	0.07	1.17	2.97	4.20	5.34	9.46	14.11	24.82	31.77
	0.2	1.90	4.87	6.91	8.82	15.54	23.23	40.77	52.12
	0.4	2.52	6.56	9.38	12.01	21.01	31.51	55.10	70.30
	0.8	3.10	8.35	12.17	15.67	26.97	40.76	70.68	89.75
-25° C 1.0 bar	0.07	1.03	2.62	3.70	4.72	8.35	12.45	21.90	28.03
	0.2	1.66	4.27	6.07	7.75	13.63	20.39	35.76	45.70
	0.4	2.17	5.69	8.16	10.46	18.24	27.40	47.84	60.98
	0.8	2.58	7.05	10.37	13.40	22.87	34.69	59.92	75.92
-30° C 0.63 bar	0.07	0.90	2.30	3.25	4.14	7.32	10.92	19.20	24.56
	0.2	1.44	3.71	5.28	6.75	11.86	17.75	31.10	39.72
	0.4	1.84	4.87	7.02	9.02	15.66	23.56	41.05	52.27
	0.8	2.08	5.82	8.67	11.25	19.00	28.97	49.76	62.86
-40° C 0.04 bar	0.07	0.68	1.73	2.45	3.12	5.51	8.22	14.44	18.47
	0.2	1.04	2.72	3.90	4.99	8.71	13.08	22.85	29.13
	0.4	1.25	3.41	4.99	6.44	11.03	16.70	28.89	36.65
	0.8	1.25	3.58	5.58	7.36	11.94	18.55	31.20	38.95

Capacities are based on 40° C liquid, 5° C superheat at valve inlet, and are maximum for the conditions listed. For each 5° C liquid is below 40° C, INCREASE capacity values by 7%. (*Sizing charts are also for Crankcase Pressure Regulators in sizes to 2 1/8 port only.)

NOTE: Due to conditions encountered with refrigeration circuits utilizing hot gas for defrosting purposes, a maximum pressure drop of .20 bar should be used in the regulator selection process. If a pressure drop of more than .20 bar is considered, the regulator could become restrictive after the termination of a defrost cycle, thereby requiring an extended pull down period. The shaded areas of the suction tables designate regulator capacities above a .20 bar pressure drop, and should not be considered for these types of systems.

A8 Pressure Regulators

Features

- Dual range spring for flexibility in application.
- Highest capacity commercial regulator in the industry.
- Molded Class H coil construction.
- Internally pilot operated.
- Manual opening stem.
- Interchangeable capacity cartridges.
- Inlet, outlet, or differential control capability.
- Sweat-in place without disassembly.
- Inlet access fitting as standard.
- Electric shut-off and electric wide open variations.
- Excellent regulation at light loads.
- DIN coil assemblies available.



Specifications

- Control range: 10" Hg to 400 psig (250mm Hg to 27.6 bar).
- Minimum fluid temperature: -40° F (-40° C).
- Design Pressure (M.R.P.): 450 psig (31.0 bar).
- UL listed (except 50 Hz version), file # SA5473.
- CSA certified, file LR20991-14.

Standard Voltages

- 120V/60Hz, 110V/50Hz
- 240V/60Hz, 220V/50Hz
- 208V/60Hz
- 240V/60Hz, 220V/50Hz (DIN)
- 240V/50Hz (DIN)

A8 Valve Nomenclature

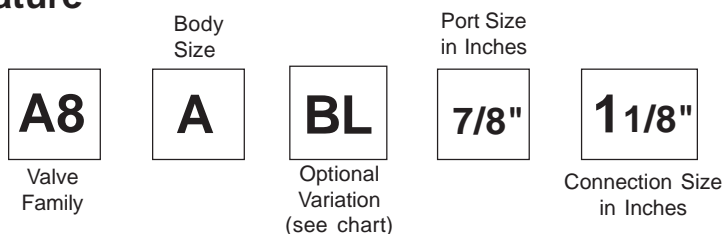

Valve Types: A8A, A81, A82. All are inlet pressure regulators.
 Optional adapter functions are as follows:

"S" Suffix	Inlet Regulator with Electric Shut-Off
"B" Suffix	Inlet Regulator with Electric Bypass Feature
"L" Suffix	Differential Pressure Regulator
"BL" Suffix	Differential Regulator with Electric Bypass Feature
"OE" Suffix	Outlet Pressure Regulator
"OES" Suffix	Outlet Pressure Regulator with Electric Shut-Off

A8 Port/Connection Size Combinations

Valve Type	Port Size	Available Connection Sizes
A8A	3/8" (9mm)	5/8", 7/8", 1-1/8" (15mm, 22mm, 28mm)
A8A	5/8" (15mm)	5/8", 7/8", 1-1/8" (15mm, 22mm, 28mm)
A8A	7/8" (22mm)	7/8", 1-1/8" (22mm, 28mm)
A81	5/8" (15mm)	1-1/8", 1-3/8" (28mm, 35mm)
A81	7/8" (22mm)	1-1/8", 1-3/8", 1-5/8", 2-1/8" (28mm, 35mm, 42mm, 54mm)
A81	1-1/8" (28mm)	1-1/8", 1-3/8", 1-5/8", 2-1/8" (28mm, 35mm, 42mm, 54mm)
A81	1-3/8" (35mm)	1-1/8", 1-3/8", 1-5/8", 2-1/8" (28mm, 35mm, 42mm, 54mm)
A82	1-5/8" (42mm)	1-5/8", 2-1/8", 2-5/8" (42mm, 54mm, 66mm)
A82	2-1/8" (54mm)	1-5/8", 2-1/8", 2-5/8" (42mm, 54mm, 66mm)
A82	2-5/8" (66mm)	1-5/8", 2-1/8", 2-5/8" (42mm, 54mm, 66mm)

Description/Variations: A8 Pressure regulators can conveniently be identified by three primary types: inlet, outlet, and differential regulator versions. Inlet pressure regulators open on a rise in inlet pressure above the valves set point, and close when the inlet pressure drops below the valve's set point.

Outlet pressure regulators maintain a constant outlet or downstream pressure. Outlet regulators will open when outlet pressure falls below the valves set point and close when the outlet pressure is above it's set point.

Differential pressure regulators will open when the pressure difference across the regulator is greater than the valves set point. Conversely, they will close when the pressure difference across the valve is below the valve's set point.

In addition, these three categories of valves, inlet, outlet, and differential, can also have optional variations added to the basic regulator, such as an electric shut-off feature, or bypass (electric wide opening) feature. Please refer to the inside front cover of this condensed catalog for a complete listing of all A8 regulator variations and their typical applications.

Pressure Ranges: All A8 series inlet and outlet pressure regulators feature a wide pressure range, 10" Hg to 400 psig (250mm Hg to 27.6 bar), thus allowing flexibility in application. Differential pressure regulators offer a single range spring capable of being set within a range of 0 to 120 psig (0 to 8.3 bar). Since it is the pressure difference across the valve which is being controlled with any differential regulator version (not inlet pressure), this range is appropriate for any application, whether applied on the low side or high side of the system. For example, discharge regulators will certainly be exposed to pressures exceeding 120 psig under normal operation. However, they are most typically set to control at about a 25 psi differential for hot gas supply purposes for defrost. Since this 25 psi set point easily falls within the range of this regulator, it is an appropriate pressure range for the application.

Installation: For those A8 regulators having an integral pilot solenoid feature, the solenoid operators utilize a spring loaded solenoid plunger design, which assists the plunger in closing off tightly against the solenoid pilot seat regardless of position or orientation. The regulator can therefore be installed in either a horizontal or vertical pipe line regardless of valve variation. Those A8 regulators that have no pilot solenoid can also be installed in a similar manner.

When brazing in line, typically a wet cloth wrapped around the valve body is recommended to dissipate heat. **If a valve is disassembled prior to installation, always have the correct gasket/ O-ring kit available for reassembly.** The internal cartridge-to-body O-ring will need to be replaced prior to reassembly.

Adjustment: Adjustment of a regulator's set point requires that the pressure being controlled be monitored by an accurate pressure gauge. Turning the valve's adjusting screw clockwise (into the bonnet) compresses the range spring and subsequently raises the valves set point. Conversely, turning the adjusting stem counter-clockwise will decrease the valve's set point. Adjusting the set point of an A8AS, A81S, or A82S regulator must be made with the solenoid energized, and the manual opening stem turned in. The adjustment of an A8AB, A81B, or A82B must be made with the solenoid de-energized, and the manual opening stem turned in.

Electrical: All A8 regulator versions utilize a molded water resistant class "H" solenoid coil with a "general purpose" coil housing as standard. A class "H" DIN coil is also available with certain voltages. Coils are designed to operate with line voltage from 85% to 110% of rated coil voltage. Operating with a coil voltage above or below these limits may result in coil burnout. Also, operating with a coil voltage below this limit will result in lowering the valves' maximum opening pressure differential, or MOPD.

Ordering Guide: Specify valve type, port and connection size, and voltage, if applicable.

NOTE: For A8 valve suction capacity tables, please reference pages 8-15 of this catalog.

A9 Pressure Regulators

Features

- Pilot operated for precise control of set point.
- External or internal equalizer.
- Available with integral electric shut-off.
- Sweat-in place without disassembly.
- Molded class H coil construction.
- DIN coil assemblies available.



Specifications

- Two pressure ranges:
 - Range A = 10" Hg vacuum to 120 psig (250 mm hg to 8.3 bar) (*hot gas bypass range*).
 - Range B = 80 psig to 220 psig (5.6 to 15.2 bar) (*typical application - receiver pressure regulator*).
- Minimum fluid temperature: -40° F (-40° C).
- Design pressure (M.R.P.): 450 psig (31.0 bar)
- All models UL listed, file # SA5473.
- CSA certified A9S & A9SE, file # LR20991-14.

Standard Voltages

- 120V/60Hz, 110V/50Hz
- 240V/60Hz, 220V/50Hz
- 208V/60Hz
- 240V/60Hz, 220V/50Hz (DIN)
- 240V/50Hz (DIN)

A9 Valve Nomenclature

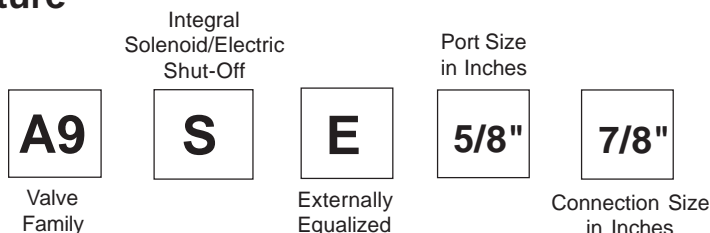

A9	Outlet Pressure Regulator
A9S	Outlet Pressure Regulator with Electric Shut-Off Feature
A9E	Externally Equalized Outlet Pressure Regulator
A9SE	Externally Equalized Outlet Pressure Regulator with Electric Shut-Off Feature

A9 Port/Connection Size Combinations

Port Size	Available Connection Sizes
3/8" (9mm)	5/8", 7/8", 1-1/8" (15mm, 22mm, 28mm)
5/8" (15mm)	5/8", 7/8", 1-1/8" (15mm, 22mm, 28mm)
7/8" (22mm)	5/8", 7/8", 1-1/8" (15mm, 22mm, 28mm)
1-1/8" (28mm)	1-1/8" (28mm)

Description: The A9 family of pilot operated outlet pressure regulators are ductile iron bodied valves with brazed copper couplings. The A9 is “internally equalized” to outlet pressure by means of a small channel or passage drilled through the outlet of the adapter which effectively communicates downstream pressure to the pilot section of the valve. The regulator therefore reacts to and controls the immediate outlet pressure of the control valve. When used as a receiver pressure regulator, range “B” should be designated when ordering.

The A9E is an “externally equalized” outlet pressure regulator and is usually applied as a hot gas bypass regulator. For those applications where the discharge gas is introduced into the inlet of the evaporator, an A9E is typically used with a small pilot line connected from the compressor suction to the external fitting on the regulator. Installed in this manner the valve senses and responds to compressor suction pressure while piped to feed discharge gas to the inlet of the evaporator. Since it is the suction pressure that the regulator is responding to and ultimately controlling, a range “A” regulator should be designated when ordering an A9E or A9SE for this application.

Installation: A9 regulators can be mounted either in a vertical or horizontal line with the refrigerant flow in the direction of the arrow on the body. These regulators may be soldered into the line without disassembly. A

wet cloth should be wrapped around the valve and the soldering flame should be directed away from the valve body.

Adjustment: Loosen the adjusting stem seal nut and turn the adjusting stem clockwise to raise the set point of the regulator. Turn the adjusting stem counter clockwise to lower the set point of the regulator. For a range “A” valve, one complete turn of the adjusting stem will result in a change in set point of about 16 psi (1.1 bar). One complete turn of the adjusting stem on a range “B” regulator will change the set point approximately 25psi (1.7 bar). The set point adjustment of an A9S or A9SE must be made with the pilot solenoid energized.

Electrical: A9S and A9SE regulators utilize a molded water resistant Class “H” solenoid coil with a general purpose coil housing which meets NEMA 3R and 4 requirements. A class “H” DIN coil is also available with certain voltages. Power consumption during normal operation will be 11 watts or less. The coils are designed to operate with a line voltage from 85% to 110% of rated coil voltage. Operating with a line voltage above or below these limits may result in coil burn out.

Ordering Guide: Specify valve type, range, port and connection size. If shut off (“S”) variation is included, specify voltage and frequency.

CK4 Check Valve

Features

- Spring-loaded, in-line check valve.
- Compact size, mounts in any position.
- A minimum pressure difference of .75 psi (.05 bar) required to fully open valve.
- Several ODS connection sizes available for most port size valves.
- Positive spring closing action.
- Lapped, metal to metal stainless steel or chrome plated seat.
- Various flanged connections available.



Specifications

- Design pressure (MRP): 500 psig, (32 bar).
- Minimum fluid temperature: -40 °F (-40 °C).
- UL listed, file # SA5473.
- CSA certified, file # LR20991-14.

CK4 Valve Nomenclature

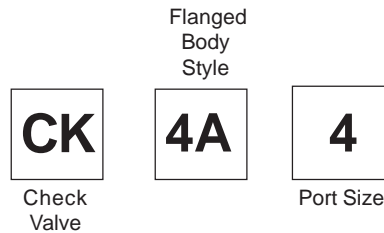

CK4 Port/Connection Size Combinations

Valve Type	Port Size	Available ODS Flange Connection Sizes
CK4A-2	1/2" (13mm)	1/2", 5/8", 7/8" (13mm, 15mm, 22mm)
CK4A-3	3/4" (20mm)	7/8", 1-1/8", 1-3/8" (22mm, 28mm, 35mm)
CK4A-4	1" (25mm)	1-1/8", 1-3/8", 1-5/8" (28mm, 35mm, 42mm)
CK4A-6	1-1/4" (32mm)	1-3/8", 1-5/8", 2-1/8" (35mm, 42mm, 54mm)
CK4A-8	2" (50mm)	1-5/8", 2-1/8", 2-5/8" (42mm, 54mm, 66mm)
CK4A-9	2-1/2" (65mm)	2-5/8", 3-1/8" (66mm, 78mm)
CK4A-0	3" (75mm)	3-1/8", 3-5/8" (78mm, 91mm)
CK4A-16	4" (100mm)	4-1/8" (103mm)

Description: CK4A check valves allow flow in one direction only, and will prevent backward flow of refrigerant should the outlet pressure increase even slightly above the valve's inlet pressure. The CK4A check valve is a flanged spring closing valve which utilizes a corrosion resistant, stainless steel or chrome plated lapped seat. This material and type of construction ensures reliable closing action and minimum seat leakage.

Typical applications for large commercial refrigeration systems include condenser liquid drain check valves, and condenser bypass lines. As a bypass check valve, it is usually installed downstream of a receiver pressure regulator. In this application, the CK4A check valve prevents back-flow through the receiver pressure regulator and into the discharge line in the event of a system shut-down.

CK4A check valves utilize mating flanges. In most instances, ODS flanges with copper couplings provide various connection sizes to match the valve to the line. The flanges used are two bolt refrigeration style (tongue and groove) on all valves up to and including 1" (25mm) port size, and four bolt on 1-1/4" (32mm) through 4" (100mm) port size.

Installation: Because of their spring closing construction, CK4A check valves can be mounted in any position in either a vertical or horizontal line. The valve must be installed with the arrow pointing in the direction of flow. After installing the CK4A between its flanges, tighten the flange bolts evenly.

Ordering Guide: Specify the CK4A port size and the connection size of the ODS flange.

CK4A Liquid Drain Capacities (Tons)

R22

Cond Temp Sat pres (psig)	Evap Temp	Pres Drop psi	CK4A2 1/2" 13 mm	CK4A3 3/4" 20 mm	Ck4A4 1" 25 mm	CK4A6 1-1/4" 32 mm	CK4A8 2" 50 mm	CK4A9 2-1/2" 65 mm	CK4A0 3" 75 mm	CK4A16 4" 100 mm
75° F (132)	-40° F	0.75	9.9	20.7	37.9	55.3	134.0	203.8	326.2	611.5
		3	19.8	41.4	75.7	110.7	267.9	407.7	652.3	1223.1
	0° F	0.75	10.5	21.9	40.1	58.6	141.9	216.0	345.6	648.0
		3	21.0	43.8	80.2	117.3	283.9	432.0	691.2	1295.9
	40° F	0.75	11.0	23.0	42.1	61.6	149.0	226.8	362.8	680.3
		3	22.0	46.0	84.2	123.1	298.0	453.6	725.7	1360.7
95° F (182)	-40° F	0.75	8.9	18.6	34.1	49.9	120.7	183.7	294.0	551.2
		3	17.8	37.3	68.2	99.7	241.5	367.5	587.9	1102.4
	0° F	0.75	9.5	19.8	36.3	53.1	128.6	195.7	313.0	587.0
		3	19.0	39.7	72.7	106.2	257.1	391.3	626.1	1173.9
	40° F	0.75	10.0	20.9	38.3	56.0	135.5	206.2	330.0	618.7
		3	20.0	41.8	76.6	112.0	271.1	412.5	660.0	1237.5
115° F (243)	-40° F	0.75	7.9	16.6	30.3	44.3	107.3	163.2	261.2	489.7
		3	15.9	33.1	60.6	88.6	214.5	326.5	522.4	979.4
	0° F	0.75	8.5	17.7	32.5	47.5	115.0	174.9	279.9	524.8
		3	17.0	35.5	65.0	95.0	229.9	349.9	559.8	1049.6
	40° F	0.75	9.0	18.8	34.4	50.3	121.8	185.3	296.5	555.9
		3	18.0	37.6	68.8	100.6	243.5	370.6	593.0	1111.8

CK4A Liquid Drain Capacities (Tons)

R134a

Cond Temp (Sat pres) psig	Evap Temp	Pres Drop psi	CK4A2 1/2" 13 mm	CK4A3 3/4" 20 mm	Ck4A4 1" 25 mm	CK4A6 1-1/4" 32 mm	CK4A8 2" 50 mm	CK4A9 2-1/2" 65 mm	CK4A0 3" 75 mm	CK4A16 4" 100 mm
75° F (78.6)	-40° F	0.75	8.9	18.6	34.1	49.8	120.6	183.5	293.6	550.5
		3	17.8	37.2	68.2	99.6	241.2	367.0	587.2	1101.0
	0° F	0.75	9.7	20.4	37.3	54.5	131.9	200.7	321.1	602.0
		3	19.5	40.7	74.5	108.9	263.7	401.3	642.1	1204.0
	40° F	0.75	10.5	22.0	40.3	58.9	142.7	217.2	347.5	651.5
		3	21.1	44.1	80.7	117.9	285.4	434.3	695.0	1303.0
95° F (113.8)	-40° F	0.75	7.9	16.4	30.0	43.9	106.2	161.7	258.6	485.0
		3	15.7	32.8	60.0	87.8	212.5	323.3	517.3	969.9
	0° F	0.75	8.7	18.1	33.2	48.5	117.3	178.5	285.6	535.6
		3	17.3	36.2	66.3	96.9	234.6	357.0	571.3	1071.1
	40° F	0.75	9.5	19.8	36.2	52.9	128.0	194.8	311.6	584.2
		3	18.9	39.5	72.3	105.7	256.0	389.5	623.2	1168.5
115° F (158.4)	-40° F	0.75	6.8	14.2	25.9	37.9	91.7	139.5	223.2	418.6
		3	13.6	28.3	51.8	75.7	183.4	279.0	446.5	837.1
	0° F	0.75	7.6	15.8	29.0	42.4	102.6	156.1	249.7	468.2
		3	15.2	31.7	58.0	84.7	205.1	312.1	499.4	936.4
	40° F	0.75	8.4	17.4	31.9	46.7	113.0	172.0	275.2	516.0
		3	16.7	34.9	63.9	93.4	226.0	344.0	550.4	1031.9

NOTE: Blue shading is for readability purposes only.

CK4A Liquid Drain Capacities (kW)

R22

Cond Temp (Sat pres) bar	Evap Temp	Pres Drop bar	CK4A2 1/2" 13 mm	CK4A3 3/4" 20 mm	CK4A4 1" 25 mm	CK4A6 1-1/4" 32 mm	CK4A8 2" 50 mm	CK4A9 2-1/2" 65 mm	CK4A0 3" 75 mm	CK4A16 4" 100 mm
25° C (9.2)	-40° C	0.05	33.7	70.3	128.8	188.2	455.6	693.3	1109.2	2079.8
		0.21	69.0	144.1	263.9	385.6	933.7	1420.8	2273.3	4262.4
	-20° C	0.05	35.5	74.1	135.8	198.4	480.4	731.0	1169.7	2193.1
		0.21	72.8	152.0	278.2	406.7	984.5	1498.2	2397.1	4494.6
	0° C	0.05	37.2	77.6	142.1	207.7	502.8	765.1	1224.2	2295.4
		0.21	76.2	159.0	291.2	425.6	1030.4	1568.0	2508.8	4704.1
30° C (10.9)	-40° C	0.05	32.2	67.2	123.0	179.7	435.1	662.1	1059.3	1986.2
		0.21	65.9	137.6	252.0	368.3	891.6	1356.8	2170.9	4070.4
	-20° C	0.05	34.0	71.0	129.9	189.9	459.7	699.5	1119.2	2098.5
		0.21	69.6	145.4	266.2	389.1	942.1	1433.6	2293.7	4300.7
	0° C	0.05	35.6	74.4	136.2	199.0	481.9	733.3	1173.3	2199.9
		0.21	73.0	152.4	279.1	407.9	987.6	1502.8	2404.6	4508.5
35° C (12.6)	-40° C	0.05	30.6	64.0	117.1	171.2	414.4	630.6	1009.0	1891.8
		0.21	62.8	131.1	240.0	350.8	849.3	1292.3	2067.7	3877.0
	-20° C	0.05	32.4	67.7	124.0	181.2	438.8	667.7	1068.4	2003.2
		0.21	66.5	138.8	254.1	371.4	899.3	1368.5	2189.5	4105.4
	0° C	0.05	34.1	71.1	130.2	190.3	460.8	701.3	1122.0	2103.8
		0.21	69.8	145.8	266.9	390.1	944.4	1437.2	2299.4	4311.5

CK4A Liquid Drain Capacities (kW)

R134a

Cond Temp (Sat pres) bar	Evap Temp	Pres Drop bar	CK4A2 1/2" 13 mm	CK4A3 3/4" 20 mm	CK4A4 1" 25 mm	CK4A6 1-1/4" 32 mm	CK4A8 2" 50 mm	CK4A9 2-1/2" 65 mm	CK4A0 3" 75 mm	CK4A16 4" 100 mm
25° C (5.5)	-40° C	0.05	30.2	63.1	115.4	168.7	408.5	621.6	994.6	1864.9
		0.21	61.9	129.2	236.6	345.8	837.2	1273.9	2038.3	3821.8
	-20° C	0.05	32.8	68.4	125.3	183.2	443.5	674.8	1079.7	2024.5
		0.21	67.2	140.3	256.8	375.4	908.8	1383.0	2212.8	4149.0
	0° C	0.05	35.3	73.7	134.9	197.1	477.3	726.3	1162.0	2178.8
		0.21	72.3	151.0	276.4	404.0	978.1	1488.4	2381.5	4465.3
30° C (6.7)	-40° C	0.05	28.5	59.6	109.1	159.5	386.2	587.7	940.3	1763.1
		0.21	58.5	122.2	223.7	326.9	791.5	1204.4	1927.0	3613.2
	-20° C	0.05	31.1	65.0	118.9	173.8	420.9	640.5	1024.8	1921.5
		0.21	63.8	133.1	243.8	356.3	862.6	1312.6	2100.2	3937.9
	0° C	0.05	33.6	70.1	128.4	187.7	454.4	691.5	1106.5	2074.6
		0.21	68.8	143.8	263.2	384.7	931.3	1417.3	2267.6	4251.8
35° C (7.8)	-40° C	0.05	26.9	56.1	102.8	150.3	363.8	553.6	885.7	1660.7
		0.21	55.1	115.1	210.7	307.9	745.5	1134.5	1815.2	3403.4
	-20° C	0.05	29.4	61.5	112.5	164.5	398.2	606.0	969.5	1817.9
		0.21	60.3	126.0	230.6	337.1	816.1	1241.8	1986.9	3725.5
	0° C	0.05	31.9	66.6	121.9	178.2	431.5	656.6	1050.6	1969.8
		0.21	65.4	136.5	249.9	365.2	884.3	1345.6	2153.0	4036.9

NOTE: Blue shading is for readability purposes only.

CK4A Liquid Drain Capacities (Tons)

R404a

Cond Temp (Sat pres) psig	Evap Temp	Pres Drop psi	CK4A2	CK4A3	Ck4A4	CK4A6	CK4A8	CK4A9	CK4A0	CK4A16
			1/2" 13 mm	3/4" 20 mm	1" 25 mm	1-1/4" 32 mm	2" 50 mm	2-1/2" 65 mm	3" 75 mm	4" 100 mm
75° F (161.2)	-40° F	0.75	6.6	13.8	25.3	37.0	89.6	136.3	218.0	408.8
		3	13.2	27.6	50.6	74.0	179.1	272.6	436.1	817.7
	0° F	0.75	7.4	15.5	28.3	41.4	100.3	152.6	244.1	457.7
		3	14.8	31.0	56.7	82.8	200.5	305.2	488.2	915.5
	40° F	0.75	8.1	17.0	31.1	45.5	110.1	167.6	268.1	502.7
		3	16.3	34.0	62.2	91.0	220.2	335.2	536.2	1005.5
95° F (219.4)	-40° F	0.75	5.5	11.5	21.0	30.7	74.3	113.0	180.8	339.1
		3	11.0	22.9	42.0	61.4	148.6	226.1	361.7	678.2
	0° F	0.75	6.3	13.1	23.9	35.0	84.7	128.9	206.3	386.8
		3	12.5	26.2	47.9	70.0	169.4	257.8	412.6	773.5
	40° F	0.75	7.0	14.6	26.7	39.0	94.3	143.5	229.7	430.6
		3	13.9	29.1	53.3	77.9	188.7	287.1	459.3	861.3
115° F (290.9)	-40° F	0.75	4.3	9.0	16.4	24.0	58.2	88.5	141.7	265.6
		3	8.6	18.0	32.9	48.1	116.4	177.1	283.3	531.2
	0° F	0.75	5.0	10.5	19.3	28.2	68.3	103.9	166.3	311.8
		3	10.1	21.1	38.6	56.4	136.6	207.8	332.6	623.5
	40° F	0.75	5.7	12.0	21.9	32.1	77.6	118.1	188.9	354.3
		3	11.5	24.0	43.9	64.1	155.2	236.2	377.9	708.5

CK4A Liquid Drain Capacities (Tons)

R507

Cond Temp (Sat pres) psig	Evap Temp	Pres Drop psi	CK4A2	CK4A3	Ck4A4	CK4A6	CK4A8	CK4A9	CK4A0	CK4A16
			1/2" 13 mm	3/4" 20 mm	1" 25 mm	1-1/4" 32 mm	2" 50 mm	2-1/2" 65 mm	3" 75 mm	4" 100 mm
75° F (167.0)	-40° F	0.75	6.6	13.7	25.1	36.6	88.7	134.9	215.9	404.8
		3	13.1	27.4	50.1	73.2	177.3	269.8	431.7	809.5
	0° F	0.75	7.3	15.2	27.9	40.7	98.6	150.1	240.2	450.3
		3	14.6	30.5	55.8	81.5	197.3	300.2	480.4	900.7
	40° F	0.75	8.0	16.7	30.5	44.6	108.1	164.5	263.1	493.4
		3	16.0	33.4	61.1	89.3	216.1	328.9	526.2	986.7
95° F (226.0)	-40° F	0.75	5.5	11.6	21.2	30.9	74.9	114.0	182.3	341.9
		3	11.1	23.1	42.3	61.9	149.8	227.9	364.7	683.8
	0° F	0.75	6.3	13.1	23.9	35.0	84.6	128.8	206.0	386.3
		3	12.5	26.1	47.8	69.9	169.3	257.6	412.1	772.7
	40° F	0.75	6.9	14.5	26.5	38.7	93.8	142.8	228.4	428.3
		3	13.9	29.0	53.0	77.5	187.6	285.5	456.8	856.5
115° F (301.0)	-40° F	0.75	4.5	9.3	17.1	25.0	60.5	92.1	147.3	276.2
		3	8.9	18.7	34.2	50.0	121.0	184.2	294.7	552.5
	0° F	0.75	5.2	10.8	19.8	28.9	69.9	106.4	170.3	319.3
		3	10.3	21.6	39.5	57.8	139.9	212.9	340.6	638.7
	40° F	0.75	5.8	12.2	22.3	32.6	78.9	120.0	192.0	360.0
		3	11.7	24.3	44.6	65.1	157.7	240.0	384.0	719.9

NOTE: Blue shading is for readability purposes only.

CK4A Liquid Drain Capacities (kW)

R404a

Cond Temp (Sat pres) bar	Evap Temp	Pres Drop bar	CK4A2 1/2" 13 mm	CK4A3 3/4" 20 mm	Ck4A4 1" 25 mm	CK4A6 1-1/4" 32 mm	CK4A8 2" 50 mm	CK4A9 2-1/2" 65 mm	CK4A0 3" 75 mm	CK4A16 4" 100 mm
25° C (11.2)	-40° C	0.05	22.2	46.4	85.0	124.3	300.9	457.9	732.6	1373.6
		0.21	45.6	95.2	174.3	254.7	616.6	938.4	1501.4	2815.1
	-20° C	0.05	24.7	51.6	94.4	138.0	334.1	508.5	813.6	1525.4
		0.21	50.6	105.7	193.5	282.8	684.8	1042.1	1667.3	3126.2
	0° C	0.05	27.0	56.4	103.2	150.8	365.1	555.6	889.0	1666.9
		0.21	55.3	115.5	211.5	309.1	748.3	1138.7	1822.0	3416.2
30° C (13.1)	-40° C	0.05	20.5	42.8	78.4	114.5	277.3	421.9	675.1	1265.8
		0.21	42.0	87.7	160.6	234.7	568.2	864.7	1383.5	2594.1
	-20° C	0.05	22.9	47.9	87.7	128.1	310.2	472.0	755.2	1415.9
		0.21	47.0	98.1	179.6	262.5	635.6	967.3	1547.6	2901.8
	0° C	0.05	25.2	52.6	96.3	140.8	340.8	518.6	829.8	1555.9
		0.21	51.6	107.8	197.4	288.5	698.5	1062.9	1700.6	3188.6
35° C (15.1)	-40° C	0.05	18.7	39.1	71.5	104.6	253.2	385.2	616.4	1155.7
		0.21	38.3	80.1	146.6	214.3	518.8	789.5	1263.2	2368.6
	-20° C	0.05	21.1	44.1	80.7	118.0	285.6	434.7	695.5	1304.0
		0.21	43.3	90.4	165.4	241.8	585.4	890.8	1425.3	2672.5
	0° C	0.05	23.4	48.8	89.3	130.5	315.9	480.8	769.2	1442.3
		0.21	47.9	99.9	183.0	267.4	647.5	985.3	1576.5	2955.9

CK4A Liquid Drain Capacities (kW)

R507

Cond Temp (Sat pres) bar	Evap Temp	Pres Drop bar	CK4A2 1/2" 13 mm	CK4A3 3/4" 20 mm	Ck4A4 1" 25 mm	CK4A6 1-1/4" 32 mm	CK4A8 2" 50 mm	CK4A9 2-1/2" 65 mm	CK4A0 3" 75 mm	CK4A16 4" 100 mm
25° C (11.6)	-40° C	0.05	22.1	46.1	84.3	123.3	298.5	454.2	726.7	1362.5
		0.21	45.2	94.4	172.9	252.6	611.6	930.8	1489.2	2792.3
	-20° C	0.05	24.3	50.8	93.1	136.0	329.4	501.2	802.0	1503.7
		0.21	49.9	104.2	190.8	278.8	675.0	1027.2	1643.5	3081.7
	0° C	0.05	26.5	55.4	101.4	148.2	358.8	546.0	873.6	1637.9
		0.21	54.3	113.5	207.8	303.7	735.3	1118.9	1790.3	3356.8
30° C (13.5)	-40° C	0.05	20.5	42.8	78.3	114.5	277.1	421.7	674.7	1265.1
		0.21	42.0	87.7	160.5	234.6	567.9	864.2	1382.8	2592.7
	-20° C	0.05	22.7	47.5	87.0	127.1	307.7	468.2	749.2	1404.7
		0.21	46.6	97.3	178.2	260.5	630.6	959.6	1535.4	2878.8
	0° C	0.05	24.9	52.0	95.2	139.1	336.8	512.5	820.0	1537.5
		0.21	51.0	106.5	195.1	285.1	690.2	1050.3	1680.5	3150.9
35° C (15.6)	-40° C	0.05	18.9	39.4	72.2	105.5	255.5	388.8	622.1	1166.5
		0.21	38.7	80.8	148.0	216.3	523.7	796.9	1275.0	2390.6
	-20° C	0.05	21.1	44.1	80.8	118.0	285.7	434.8	695.7	1304.5
		0.21	43.3	90.4	165.5	241.9	585.6	891.1	1425.8	2673.4
	0° C	0.05	23.2	48.5	88.9	129.9	314.5	478.5	765.7	1435.6
		0.21	47.6	99.5	182.1	266.2	644.5	980.7	1569.2	2942.2

NOTE: Blue shading is for readability purposes only.

Condenser Pressure Control

For Air Cooled Condensers

Parker Refrigerating Specialties and Flo-Con regulators provide the wide range of adjustment of condenser and receiver pressures required for the most efficient operation of large air-cooled condenser systems. The regulators are an integral part of the refrigeration system and provide direct control of condenser and receiver pressures to achieve satisfactory system operation with minimum energy consumption.

Condenser pressure control is needed for one or more of the following reasons:

1. To maintain sufficient receiver pressure to insure flow of an adequate amount of liquid to the evaporator for proper temperature control and adequate refrigeration capacity.
2. To permit start up during cold weather conditions by quickly developing adequate receiver pressure.
3. To provide an ample supply of hot gas for defrosts, reheat or heat reclamation systems.
4. To prevent flash gas in the liquid lines. With no pressure control, at very low ambient temperatures the cold liquid may be at almost saturated conditions because of the low condensing pressure. The lack of sub-cooling may cause the liquid to evaporate when the liquid lines pass through warm areas or where pressure drops take place (filters, valves, etc.). The presence of flash vapor would affect the performance of expansion valves, eroding seats, causing irregular flow, and reducing capacity.

Types of systems

Two systems of variable condenser pressure control are shown on the opposite page. Figure 1 shows a Liquid Drain Control Method using a regulator in the liquid line to provide the desired condenser pressure.

This method is ideal for large capacity systems since a smaller regulator is required for liquid line than for discharge line.

Figure 2 shows a Discharge Gas Control Method using a regulator in the discharge line. In both cases a bypass regulator is used to control the receiver pressure by feeding it with high-pressure gas as necessary.

This method is particularly suitable for systems requiring hot gas defrost, heat reclaim, and for ease of start up of systems with a cold receiver.

Valve Functions

Valve A in Fig. 1 is an Inlet Pressure Regulator in the liquid drain line from the condenser, and senses the condenser pressure. The regulator closes as the condenser pressure drops below the set point, thus back flooding the condenser and reducing the inside surface area available for condensing.

Valve in Fig. 1 and 2 is an Outlet Pressure Regulator in the bypass line from compressor discharge to the condenser liquid drain line. This valve senses the receiver pressure and opens when the pressure drops below the set point, thus maintaining the receiver pressure.

Valve C in Fig. 1 and 2 is an In-line Check valve in the liquid drain line to prevent higher pressure from backing up into the condenser during low ambient conditions when the compressor is idle.

Valve D in Fig. 2 is an Inlet Pressure Regulator in the compressor discharge line. This regulator senses the discharge pressure and closes as the pressure drops below the set point, thus maintaining the discharge pressure at the desired level.

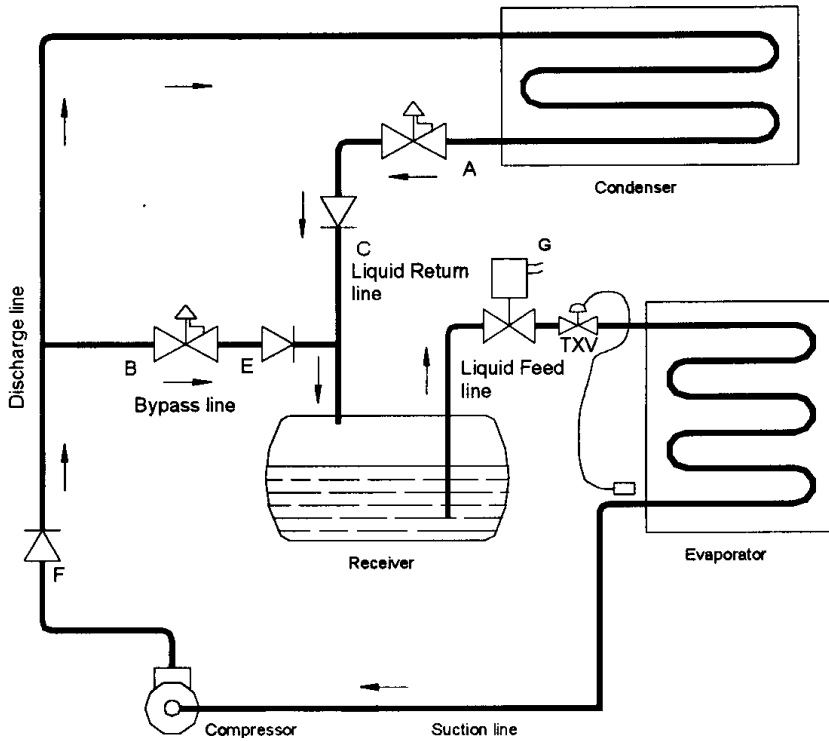

Figure 1 - Liquid drain method, condenser pressure control. (See page 72 for symbol legend.)

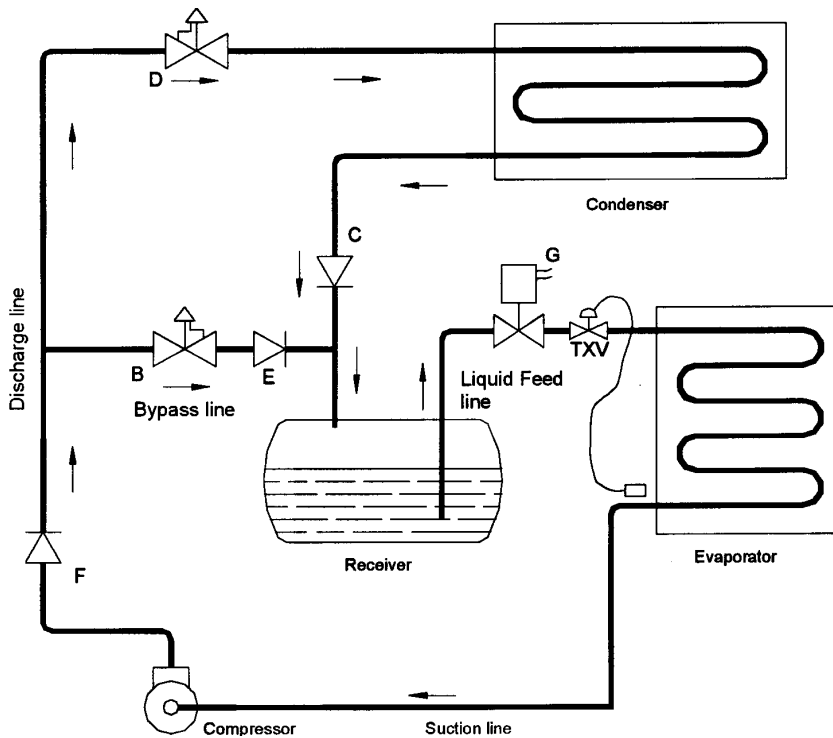

Figure 2 - Discharge gas control method, condenser pressure control. (See page 72 for symbol legend.)

Valve Legend				
Label	Valve Function	Application	Design	Selection Page
A	Inlet Pressure Regulator	Liquid Drain	A8	28-31
B	Outlet Pressure Regulator	Condenser Bypass	A9 or A8_OE	48-55
C	Check Valve	Liquid Drain	CK4A	40-47
D	Inlet Pressure Regulator	Discharge Pressure	A8	32-39
E	Check Valve	Condenser Bypass	CK4A	40-47
F	Check Valve	Compressor Discharge	CK4A	40-47
G	Solenoid Valve	Liquid Feed	SC	65

A8 Liquid Drain Capacities (Tons)

R22

Cond Temp (Sat pres) psig	Evap Temp (Sat Pres) psig	Pres Drop psi	A8	A8	A8	A81	A81	A82	A82	A82
			3/8" 9 mm	5/8" 15 mm	7/8" 22 mm	1-1/8" 28 mm	1-3/8" 35 mm	1-5/8" 42 mm	2-1/8" 54 mm	2-5/8" 66 mm
75° F (132)	-40° F (0.5)	3	8.7	22.1	31.2	39.7	70.4	104.8	184.6	236.5
		6	12.4	31.3	44.1	56.1	99.5	148.3	261.1	334.4
	0° F (24.0)	3	9.3	23.5	33.0	42.0	74.5	111.1	195.6	250.5
		6	13.1	33.2	46.7	59.4	105.4	157.1	276.7	354.3
	40° F (68.5)	3	9.7	24.6	34.7	44.1	78.3	116.6	205.4	263.1
		6	13.7	34.8	49.0	62.4	110.7	164.9	290.5	372.0
95° F (182)	-40° F (0.5)	3	7.9	19.9	28.1	35.7	63.4	94.5	166.4	213.1
		6	11.1	28.2	39.7	50.6	89.7	133.6	235.3	301.4
	0° F (24.0)	3	8.4	21.2	29.9	38.1	67.5	100.6	177.2	227.0
		6	11.9	30.0	42.3	53.8	95.5	142.3	250.6	321.0
	40° F (68.5)	3	8.8	22.4	31.5	40.1	71.2	106.1	186.8	239.2
		6	12.5	31.7	44.6	56.8	100.7	150.0	264.2	338.3
115° F (243)	-40° F (0.5)	3	7.0	17.7	25.0	31.8	56.3	84.0	147.9	189.4
		6	9.9	25.1	35.3	44.9	79.7	118.7	209.1	267.8
	0° F (24.0)	3	7.5	19.0	26.7	34.0	60.4	90.0	158.4	202.9
		6	10.6	26.9	37.8	48.1	85.4	127.2	224.1	287.0
	40° F (68.5)	3	7.9	20.1	28.3	36.1	64.0	95.3	167.8	215.0
		6	11.2	28.5	40.1	51.0	90.4	134.8	237.4	304.0

A8, Liquid Drain Capacities (Tons)

R134a

Cond Temp (Sat pres) psig	Evap Temp (Sat Pres) psig	Pres Drop psi	A8	A8	A8	A81	A81	A82	A82	A82
			3/8" 9 mm	5/8" 15 mm	7/8" 22 mm	1-1/8" 28 mm	1-3/8" 35 mm	1-5/8" 42 mm	2-1/8" 54 mm	2-5/8" 66 mm
75° F (78.6)	-40° F (14.7 in. hg)	3	7.9	19.9	28.0	35.7	63.3	94.4	166.2	212.9
		6	11.1	28.2	39.7	50.5	89.6	133.5	235.0	301.0
	0° F (6.5)	3	8.6	21.8	30.7	39.0	69.3	103.2	181.7	232.8
		6	12.2	30.8	43.4	55.2	97.9	145.9	257.0	329.2
	40° F (35.1)	3	9.3	23.6	33.2	42.3	75.0	111.7	196.7	251.9
		6	13.2	33.3	46.9	59.8	106.0	158.0	278.2	356.3
95° F (113.8)	-40° F (14.7 in. hg)	3	6.9	17.6	24.7	31.5	55.8	83.1	146.4	187.5
		6	9.8	24.8	34.9	44.5	78.9	117.6	207.1	265.2
	0° F (6.5)	3	7.7	19.4	27.3	34.7	61.6	91.8	161.7	207.1
		6	10.8	27.4	38.6	49.1	87.1	129.8	228.7	292.9
	40° F (35.1)	3	8.3	21.1	29.8	37.9	67.2	100.2	176.4	225.9
		6	11.8	29.9	42.1	53.6	95.1	141.6	249.5	319.5
115° F (158.4)	-40° F (14.7 in. hg)	3	6.0	15.1	21.3	27.1	48.2	71.8	126.4	161.8
		6	8.5	21.4	30.2	38.4	68.1	101.5	178.7	228.9
	0° F (6.5)	3	6.7	16.9	23.9	30.4	53.9	80.3	141.4	181.0
		6	9.5	24.0	33.7	42.9	76.2	113.5	199.9	256.0
	40° F (35.1)	3	7.4	18.7	26.3	33.5	59.4	88.5	155.8	199.5
		6	10.4	26.4	37.2	47.3	83.9	125.1	220.3	282.1

NOTE: Blue shading is for readability purposes only.

A8 Liquid Drain Capacities (Kilowatts)

R22

Cond Temp (Sat Pres) bar	Evap Temp (Sat Pres) bar	Pres Drop bar	A8	A8	A8	A81	A81	A82	A82	A82
			3/8" 9 mm	5/8" 15 mm	7/8" 22 mm	1-1/8" 28 mm	1-3/8" 35 mm	1-5/8" 42 mm	2-1/8" 54 mm	2-5/8" 66 mm
25° C (9.2)	-40° C (0.0)	0.2	29.7	75.3	106.0	134.9	239.3	356.5	627.9	804.2
		0.4	42.0	106.4	149.9	190.8	338.4	504.2	888.0	1137.3
	-20° C (1.4)	0.2	31.3	79.4	111.7	142.2	252.3	376.0	662.1	848.0
		0.4	44.3	112.2	158.0	201.2	356.8	531.7	936.4	1199.3
	0° C (4.0)	0.2	32.8	83.1	117.0	148.9	264.1	393.5	693.0	887.5
		0.4	46.4	117.5	165.4	210.5	373.5	556.5	980.0	1255.2
30° C (10.9)	-40° C (0.0)	0.2	28.4	71.9	101.2	128.8	228.5	340.5	599.6	768.0
		0.4	40.1	101.7	143.1	182.2	323.2	481.5	848.0	1086.1
	-20° C (1.4)	0.2	30.0	75.9	106.9	136.1	241.4	359.8	633.6	811.4
		0.4	42.4	107.4	151.2	192.5	341.4	508.8	896.0	1147.5
	0° C (4.0)	0.2	31.4	79.6	112.1	142.7	253.1	377.1	664.2	850.6
		0.4	44.4	112.6	158.5	201.8	357.9	533.3	939.3	1203.0
35° C (12.6)	-40° C (0.0)	0.2	27.0	68.5	96.4	122.7	217.6	324.3	571.1	731.5
		0.4	38.2	96.8	136.3	173.5	307.8	458.6	807.7	1034.5
	-20° C (1.4)	0.2	28.6	72.5	102.1	129.9	230.5	343.4	604.8	774.6
		0.4	40.5	102.5	144.3	183.7	325.9	485.7	855.3	1095.4
	0° C (4.0)	0.2	30.1	76.1	107.2	136.4	242.0	360.6	635.1	813.5
		0.4	42.5	107.7	151.6	193.0	342.3	510.0	898.2	1150.4

A8, Liquid Drain Capacities (Kilowatts)

R134a

Cond Temp (Sat Pres) bar	Evap Temp (Sat Pres) bar	Pres Drop bar	A8	A8	A8	A81	A81	A82	A82	A82
			3/8" 9 mm	5/8" 15 mm	7/8" 22 mm	1-1/8" 28 mm	1-3/8" 35 mm	1-5/8" 42 mm	2-1/8" 54 mm	2-5/8" 66 mm
25° C (5.5)	-40° C (373 mm hg)	0.2	26.6	67.5	95.0	120.9	214.5	319.7	563.0	721.1
		0.4	37.7	95.4	134.4	171.0	303.4	452.1	796.2	1019.8
	-20° C (914 mm hg)	0.2	28.9	73.3	103.2	131.3	232.9	347.1	611.2	782.8
		0.4	40.9	103.6	145.9	185.7	329.4	490.8	864.4	1107.1
	0° C (1.9)	0.2	31.1	78.9	111.0	141.3	250.7	373.5	657.8	842.5
		0.4	44.0	111.5	157.0	199.8	354.5	528.2	930.3	1191.5
30° C (6.7)	-40° C (373 mm hg)	0.2	25.2	63.8	89.8	114.3	202.8	302.2	532.3	681.7
		0.4	35.6	90.2	127.0	161.7	286.9	427.4	752.7	964.1
	-20° C (914 mm hg)	0.2	27.5	69.5	97.9	124.6	221.1	329.4	580.1	743.0
		0.4	38.8	98.3	138.5	176.2	312.6	465.8	820.4	1050.7
	0° C (1.9)	0.2	29.6	75.1	105.7	134.6	238.7	355.7	626.3	802.2
		0.4	41.9	106.2	149.5	190.3	337.5	503.0	885.8	1134.5
35° C (7.8)	-40° C (373 mm hg)	0.2	23.7	60.1	84.6	107.7	191.1	284.7	501.4	642.1
		0.4	33.6	85.0	119.7	152.3	270.2	402.6	709.1	908.1
	-20° C (914 mm hg)	0.2	26.0	65.8	92.6	117.9	209.1	311.6	548.8	702.9
		0.4	36.7	93.0	131.0	166.7	295.8	440.7	776.2	994.1
	0° C (1.9)	0.2	28.1	71.3	100.4	127.8	226.6	337.7	594.7	761.7
		0.4	39.8	100.8	141.9	180.7	320.5	477.6	841.0	1077.2

NOTE: Blue shading is for readability purposes only.

A8, Liquid Drain Capacities (Tons)

R404a

Cond Temp (Sat Pres) psig	Evap Temp (Sat Pres) psig	Pres Drop psi	A8 3/8" 9 mm	A8 5/8" 15 mm	A8 7/8" 22 mm	A81 1-1/8" 28 mm	A81 1-3/8" 35 mm	A82 1-5/8" 42 mm	A82 2-1/8" 54 mm	A82 2-5/8" 66 mm
75° F (161.2)	-40° F (2.7)	3	5.8	14.8	20.8	26.5	47.0	70.1	123.4	158.1
		6	8.3	20.9	29.5	37.5	66.5	99.1	174.6	223.6
	0° F (33.5)	3	6.5	16.6	23.3	29.7	52.7	78.5	138.2	177.0
		6	9.2	23.4	33.0	42.0	74.5	111.0	195.4	250.3
	40° F (86.4)	3	7.2	18.2	25.6	32.6	57.8	86.2	151.8	194.4
		6	10.2	25.7	36.2	46.1	81.8	121.9	214.6	274.9
95° F (219.4)	-40° F (2.7)	3	4.8	12.3	17.3	22.0	39.0	58.1	102.4	131.1
		6	6.9	17.4	24.4	31.1	55.2	82.2	144.8	185.4
	0° F (33.5)	3	5.5	14.0	19.7	25.1	44.5	66.3	116.8	149.5
		6	7.8	19.8	27.9	35.5	62.9	93.8	165.1	211.5
	40° F (86.4)	3	6.2	15.6	21.9	27.9	49.5	73.8	130.0	166.5
		6	8.7	22.0	31.0	39.5	70.1	104.4	183.9	235.5
115° F (290.9)	-40° F (2.7)	3	3.8	9.6	13.5	17.2	30.6	45.5	80.2	102.7
		6	5.4	13.6	19.1	24.4	43.2	64.4	113.4	145.2
	0° F (33.5)	3	4.5	11.3	15.9	20.2	35.9	53.4	94.1	120.6
		6	6.3	16.0	22.5	28.6	50.7	75.6	133.1	170.5
	40° F (86.4)	3	5.1	12.8	18.1	23.0	40.8	60.7	107.0	137.0
		6	7.2	18.1	25.5	32.5	57.6	85.9	151.3	193.7

A8, Liquid Drain Capacities (Tons)

R507

Cond Temp (Sat Pres) psig	Evap Temp (Sat Pres) psig	Pres Drop psi	A8 3/8" 9 mm	A8 5/8" 15 mm	A8 7/8" 22 mm	A81 1-1/8" 28 mm	A81 1-3/8" 35 mm	A82 1-5/8" 42 mm	A82 2-1/8" 54 mm	A82 2-5/8" 66 mm
75° F (167.0)	-40° F (5.5)	3	5.8	14.6	20.6	26.3	46.6	69.4	122.2	156.5
		6	8.2	20.7	29.2	37.1	65.9	98.1	172.8	221.3
	0° F (35.2)	3	6.4	16.3	22.9	29.2	51.8	77.2	136.0	174.1
		6	9.1	23.0	32.5	41.3	73.3	109.2	192.3	246.3
	40° F (89.8)	3	7.0	17.9	25.1	32.0	56.8	84.6	148.9	190.8
		6	10.0	25.3	35.6	45.3	80.3	119.6	210.6	269.8
95° F (226.0)	-40° F (5.5)	3	4.9	12.4	17.4	22.2	39.3	58.6	103.2	132.2
		6	6.9	17.5	24.6	31.4	55.6	82.9	146.0	187.0
	0° F (35.2)	3	5.5	14.0	19.7	25.1	44.4	66.2	116.6	149.4
		6	7.8	19.8	27.8	35.4	62.9	93.7	164.9	211.3
	40° F (89.8)	3	6.1	15.5	21.8	27.8	49.3	73.4	129.3	165.6
		6	8.7	21.9	30.9	39.3	69.7	103.8	182.8	234.2
115° F (301.0)	-40° F (5.5)	3	3.9	10.0	14.1	17.9	31.8	47.4	83.4	106.8
		6	5.6	14.1	19.9	25.3	44.9	67.0	117.9	151.1
	0° F (35.2)	3	4.6	11.6	16.3	20.7	36.7	54.7	96.4	123.5
		6	6.5	16.3	23.0	29.3	52.0	77.4	136.3	174.6
	40° F (89.8)	3	5.1	13.0	18.3	23.3	41.4	61.7	108.7	139.2
		6	7.3	18.4	25.9	33.0	58.6	87.3	153.7	196.8

NOTE: Blue shading is for readability purposes only.

A8, Liquid Drain Capacities (Kilowatts)

R404a

Cond Temp (Sat Pres) bar	Evap Temp (Sat Pres) bar	Pres Drop bar	A8 3/8" 9 mm	A8 5/8" 15 mm	A8 7/8" 22 mm	A81 1-1/8" 28 mm	A81 1-3/8" 35 mm	A82 1-5/8" 42 mm	A82 2-1/8" 54 mm	A82 2-5/8" 66 mm
25° C (11.2)	-40° C (0.3)	0.2	19.6	49.7	70.0	89.1	158.0	235.5	414.7	531.1
		0.4	27.8	70.3	99.0	126.0	223.5	333.0	586.5	751.1
	-20° C (2.0)	0.2	21.8	55.2	77.7	98.9	175.5	261.5	460.5	589.8
		0.4	30.8	78.1	109.9	139.9	248.2	369.8	651.3	834.1
	0° C (4.9)	0.2	23.8	60.3	84.9	108.1	191.8	285.8	503.3	644.6
		0.4	33.7	85.3	120.1	152.9	271.2	404.1	711.7	911.5
30° C (13.1)	-40° C (0.3)	0.2	18.1	45.8	64.5	82.1	145.6	217.0	382.2	489.4
		0.4	25.6	64.8	91.2	116.1	205.9	306.9	540.4	692.2
	-20° C (2.0)	0.2	20.2	51.2	72.1	91.8	162.9	242.7	427.5	547.5
		0.4	28.6	72.5	102.0	129.9	230.4	343.3	604.5	774.3
	0° C (4.9)	0.2	22.2	56.3	79.3	100.9	179.0	266.7	469.7	601.6
		0.4	31.4	79.6	112.1	142.7	253.1	377.2	664.3	850.8
35° C (15.1)	-40° C (0.3)	0.2	16.5	41.8	58.9	75.0	133.0	198.1	348.9	446.9
		0.4	23.3	59.2	83.3	106.0	188.0	280.2	493.5	632.0
	-20° C (2.0)	0.2	18.6	47.2	66.4	84.6	150.0	223.6	393.7	504.2
		0.4	26.3	66.7	94.0	119.6	212.2	316.1	556.8	713.1
	0° C (4.9)	0.2	20.6	52.2	73.5	93.5	165.9	247.3	435.4	557.7
		0.4	29.1	73.8	103.9	132.3	234.7	349.7	615.8	788.7

A8, Liquid Drain Capacities (Kilowatts)

R507

Cond Temp (Sat Pres) bar	Evap Temp (Sat Pres) bar	Pres Drop bar	A8 3/8" 9 mm	A8 5/8" 15 mm	A8 7/8" 22 mm	A81 1-1/8" 28 mm	A81 1-3/8" 35 mm	A82 1-5/8" 42 mm	A82 2-1/8" 54 mm	A82 2-5/8" 66 mm
25° C (11.6)	-40° C (0.4)	0.2	19.5	49.3	69.4	88.4	156.8	233.6	411.3	526.8
		0.4	27.5	69.7	98.2	125.0	221.7	330.3	581.7	745.1
	-20° C (2.1)	0.2	21.5	54.4	76.6	97.5	173.0	257.8	454.0	581.4
		0.4	30.4	77.0	108.4	137.9	244.7	364.6	642.0	822.3
	0° C (5.2)	0.2	23.4	59.3	83.5	106.2	188.4	280.8	494.5	633.3
		0.4	33.1	83.8	118.0	150.2	266.5	397.1	699.3	895.7
30° C (13.5)	-40° C (0.4)	0.2	18.1	45.8	64.5	82.1	145.5	216.9	381.9	489.2
		0.4	25.6	64.7	91.2	116.0	205.8	306.7	540.1	691.8
	-20° C (2.1)	0.2	20.1	50.8	71.6	91.1	161.6	240.8	424.1	543.2
		0.4	28.4	71.9	101.2	128.8	228.6	340.6	599.8	768.1
	0° C (5.2)	0.2	22.0	55.6	78.3	99.7	176.9	263.6	464.2	594.5
		0.4	31.1	78.7	110.8	141.0	250.2	372.7	656.4	840.7
35° C (15.6)	-40° C (0.4)	0.2	16.7	42.2	59.4	75.7	134.2	200.0	352.2	451.1
		0.4	23.6	59.7	84.1	107.0	189.8	282.8	498.1	637.9
	-20° C (2.1)	0.2	18.6	47.2	66.5	84.6	150.1	223.6	393.8	504.4
		0.4	26.4	66.8	94.0	119.6	212.2	316.3	557.0	713.3
	0° C (5.2)	0.2	20.5	52.0	73.1	93.1	165.2	246.1	433.4	555.1
		0.4	29.0	73.5	103.4	131.7	233.6	348.0	613.0	785.0

NOTE: Blue shading is for readability purposes only.

A8 Discharge Capacities (Tons)

R22

Cond Temp (Sat Pres) psig	Evap Temp (Sat Pres) psig	Discharge Temp	Pres Drop psi	A8A 3/8" 9 mm	A8A 5/8" 15 mm	A8A 7/8" 22 mm	A81 1-1/8" 28 mm	A81 1-3/8" 35 mm	A82 1-5/8" 42 mm	A82 2-1/8" 54 mm	A82 2-5/8" 66 mm		
75° F (132)	-40° F (0.5)	140° 180° 220°	3	1.5	3.8	5.3	6.8	12.0	17.9	31.4	40.2		
				1.4	3.6	5.1	6.5	11.4	17.1	30.0	38.4		
				1.4	3.5	4.9	6.2	11.0	16.4	28.8	36.9		
		75° F (132)	0° F (24.0)	140° 180° 220°	3	2.1	5.3	7.5	9.6	16.9	25.2	44.3	56.7
						2.0	5.1	7.2	9.1	16.1	24.1	42.3	54.2
						1.9	4.9	6.9	8.8	15.5	23.1	40.7	52.0
75° F (132)	40° F (68.5)			140° 180° 220°	3	1.6	4.0	5.6	7.2	12.7	18.9	33.3	42.6
						1.5	3.8	5.4	6.8	12.1	18.1	31.8	40.7
						1.4	3.7	5.2	6.6	11.6	17.4	30.6	39.1
		75° F (132)	40° F (68.5)	140° 180° 220°	6	2.2	5.6	7.9	10.1	17.9	26.7	47.0	60.1
						2.1	5.4	7.6	9.7	17.1	25.5	44.9	57.4
						2.0	5.2	7.3	9.3	16.4	24.5	43.1	55.1
95° F (182)	-40° F (0.5)			140° 180° 220°	3	1.6	4.1	5.8	7.4	13.0	19.4	34.2	43.8
						1.5	3.9	5.5	7.0	12.4	18.4	32.4	41.5
						1.5	3.7	5.2	6.7	11.8	17.6	31.0	39.7
		95° F (182)	0° F (24.0)	140° 180° 220°	3	2.3	5.8	8.2	10.4	18.4	27.5	48.3	61.8
						2.2	5.5	7.7	9.9	17.5	26.1	45.8	58.6
						2.1	5.2	7.4	9.4	16.7	24.9	43.8	56.1
95° F (182)	0° F (24.0)			140° 180° 220°	6	2.4	6.2	8.7	11.1	19.6	29.2	51.4	65.8
						2.3	5.8	8.2	10.5	18.6	27.7	48.8	62.4
						2.2	5.6	7.9	10.1	17.8	26.5	46.7	59.7
		95° F (182)	40° F (68.5)	140° 180° 220°	3	1.8	4.6	6.5	8.3	14.6	21.8	38.4	49.1
						1.7	4.4	6.2	7.8	13.9	20.7	36.4	46.6
						1.6	4.2	5.9	7.5	13.3	19.8	34.8	44.6
95° F (182)	40° F (68.5)			140° 180° 220°	6	2.5	6.5	9.2	11.7	20.7	30.8	54.2	69.4
						2.4	6.2	8.7	11.1	19.6	29.2	51.4	65.8
						2.3	5.9	8.3	10.6	18.8	28.0	49.2	63.0
		115° F (243)	-40° F (0.5)	140° 180° 220°	3	1.7	4.4	6.2	7.9	14.0	20.9	36.8	47.1
						1.6	4.1	5.8	7.4	13.2	19.6	34.5	44.2
						1.5	3.9	5.5	7.1	12.5	18.6	32.8	42.0
115° F (243)	0° F (24.0)			140° 180° 220°	6	2.4	6.2	8.8	11.2	19.8	29.6	52.0	66.5
						2.3	5.8	8.2	10.5	18.6	27.7	48.8	62.4
						2.2	5.6	7.8	10.0	17.7	26.4	46.4	59.3
		115° F (243)	40° F (68.5)	140° 180° 220°	3	1.9	4.7	6.7	8.5	15.0	22.4	39.4	50.5
						1.7	4.4	6.2	8.0	14.1	21.0	37.0	47.3
						1.7	4.2	5.9	7.6	13.4	20.0	35.2	45.0
115° F (243)	40° F (68.5)			140° 180° 220°	6	2.6	6.7	9.4	12.0	21.2	31.7	55.7	71.3
						2.5	6.3	8.8	11.3	19.9	29.7	52.3	66.9
						2.3	5.9	8.4	10.7	18.9	28.2	49.7	63.6
		115° F (243)	40° F (68.5)	140° 180° 220°	3	2.0	5.0	7.1	9.0	15.9	23.7	41.7	53.4
						1.8	4.7	6.6	8.4	14.9	22.3	39.2	50.2
						1.8	4.5	6.3	8.0	14.2	21.2	37.3	47.7
115° F (243)	40° F (68.5)			140° 180° 220°	6	2.8	7.1	10.0	12.7	22.5	33.6	59.0	75.5
						2.6	6.6	9.4	11.9	21.1	31.5	55.4	70.9
						2.5	6.3	8.9	11.3	20.1	29.9	52.6	67.4



A8 Discharge Capacities (Kilowatts) R22

Cond Temp (Sat Pres) bar	Evap Temp (Sat Pres) bar	Discharge Temp	Pres Drop bar	A8A 3/8" 9 mm	A8A 5/8" 15 mm	A8A 7/8" 22 mm	A81 1-1/8" 28 mm	A81 1-3/8" 35 mm	A82 1-5/8" 42 mm	A82 2-1/8" 54 mm	A82 2-5/8" 66 mm	
25° C (9.2)	-40° C (0.0)	60°	0.2	5.1	13.0	18.4	23.4	41.5	61.9	108.9	139.4	
		80°		4.9	12.5	17.6	22.5	39.8	59.4	104.4	133.7	
		100°		4.7	12.1	17.0	21.7	38.4	57.2	100.7	128.9	
	25° C (9.2)	-20° C (1.4)	60°	0.4	7.2	18.4	26.0	33.2	58.6	87.5	153.8	196.8
			80°		6.9	17.6	24.9	31.8	56.2	83.9	147.5	188.7
			100°		6.7	17.0	24.0	30.6	54.2	80.8	142.1	181.8
25° C (9.2)		0° C (4.0)	60°	0.2	5.4	13.8	19.4	24.7	43.8	65.3	114.8	147.0
			80°		5.2	13.2	18.6	23.7	42.0	62.6	110.1	141.0
			100°		5.0	12.7	17.9	22.9	40.5	60.3	106.2	135.9
	25° C (9.2)	0° C (4.0)	60°	0.4	7.6	19.4	27.4	35.0	61.8	92.3	162.2	207.5
			80°		7.3	18.6	26.3	33.5	59.3	88.5	155.5	198.9
			100°		7.0	17.9	25.4	32.3	57.1	85.2	149.8	191.7
30° C (10.9)		-40° C (0.0)	60°	0.2	5.7	14.4	20.3	25.9	45.8	68.3	120.2	153.9
			80°		5.4	13.8	19.5	24.8	43.9	65.5	115.3	147.6
			100°		5.2	13.3	18.8	23.9	42.3	63.1	111.1	142.2
	30° C (10.9)	-20° C (1.4)	60°	0.4	8.0	20.3	28.7	36.6	64.7	96.6	169.7	217.2
			80°		7.6	19.5	27.5	35.1	62.0	92.6	162.7	208.2
			100°		7.4	18.8	26.5	33.8	59.8	89.2	156.8	200.7
30° C (10.9)		0° C (4.0)	60°	0.2	5.3	13.6	19.1	24.4	43.2	64.3	113.2	145.0
			80°		5.1	13.0	18.3	23.3	41.3	61.6	108.3	138.7
			100°		4.9	12.5	17.6	22.4	39.7	59.2	104.2	133.4
	30° C (10.9)	-20° C (1.4)	60°	0.4	7.5	19.1	27.1	34.5	61.0	91.0	160.0	204.7
			80°		7.2	18.3	25.9	33.0	58.3	87.0	153.0	195.8
			100°		6.9	17.6	24.9	31.7	56.1	83.7	147.2	188.3
30° C (10.9)		0° C (4.0)	60°	0.2	5.6	14.3	20.2	25.7	45.6	68.0	119.6	153.2
			80°		5.4	13.7	19.3	24.6	43.6	65.0	114.4	146.5
			100°		5.2	13.2	18.6	23.7	42.0	62.6	110.1	141.0
	30° C (10.9)	-20° C (1.4)	60°	0.4	7.9	20.2	28.6	36.4	64.4	96.1	169.0	216.3
			80°		7.6	19.3	27.3	34.8	61.6	91.9	161.6	206.8
			100°		7.3	18.6	26.3	33.5	59.3	88.5	155.5	199.0
30° C (10.9)		0° C (4.0)	60°	0.2	5.9	15.0	21.2	27.0	47.8	71.3	125.4	160.6
			80°		5.7	14.4	20.3	25.8	45.7	68.2	120.0	153.6
			100°		5.4	13.8	19.5	24.8	44.0	65.6	115.4	147.8
	35° C (12.6)	-40° C (0.0)	60°	0.4	8.3	21.2	30.0	38.2	67.5	100.8	177.2	226.7
			80°		8.0	20.3	28.7	36.5	64.6	96.4	169.5	216.8
			100°		7.7	19.5	27.6	35.1	62.1	92.7	163.0	208.6
35° C (12.6)		-20° C (1.4)	60°	0.2	5.5	14.1	19.8	25.3	44.8	66.7	117.4	150.3
			80°		5.3	13.4	18.9	24.1	42.7	63.6	112.0	143.4
			100°		5.1	12.9	18.2	23.1	41.0	61.1	107.5	137.7
	35° C (12.6)	0° C (4.0)	60°	0.4	7.8	19.9	28.1	35.8	63.2	94.3	165.9	212.3
			80°		7.4	18.9	26.7	34.1	60.3	89.9	158.2	202.4
			100°		7.1	18.2	25.7	32.7	57.9	86.4	151.8	194.3
35° C (12.6)		-20° C (1.4)	60°	0.2	5.9	14.9	21.0	26.8	47.4	70.7	124.4	159.2
			80°		5.6	14.2	20.0	25.5	45.2	67.4	118.6	151.8
			100°		5.4	13.6	19.2	24.5	43.4	64.7	113.9	145.8
	35° C (12.6)	0° C (4.0)	60°	0.4	8.3	21.0	29.7	37.9	67.0	99.9	175.7	224.8
			80°		7.9	20.0	28.3	36.1	63.8	95.2	167.5	214.3
			100°		7.6	19.2	27.2	34.6	61.3	91.4	160.8	205.8
35° C (12.6)		-20° C (1.4)	60°	0.2	6.2	15.6	22.1	28.1	49.8	74.2	130.6	167.2
			80°		5.9	14.9	21.0	26.8	47.5	70.8	124.5	159.4
			100°		5.6	14.3	20.2	25.7	45.6	68.0	119.6	153.1
	35° C (12.6)	0° C (4.0)	60°	0.4	8.7	22.1	31.2	39.8	70.3	104.9	184.5	236.1
			80°		8.3	21.1	29.7	37.9	67.0	100.0	175.9	225.1
			100°		7.9	20.2	28.6	36.4	64.4	96.0	168.9	216.1

A8 Discharge Capacities (Tons)

R134a

Cond Temp (Sat Pres) psig	Evap Temp (Sat Pres) psig	Discharge Temp	Pres Drop psi	A8A 3/8" 9 mm	A8A 5/8" 15 mm	A8A 7/8" 22 mm	A81 1-1/8" 28 mm	A81 1-3/8" 35 mm	A82 1-5/8" 42 mm	A82 2-1/8" 54 mm	A82 2-5/8" 66 mm		
75° F (78.6)	-40° F (14.7 in. hg)	140° 180° 220°	3	1.1	2.9	4.1	5.2	9.2	13.7	24.1	30.8		
				1.1	2.8	3.9	5.0	8.8	13.1	23.0	29.5		
				1.0	2.7	3.7	4.8	8.4	12.6	22.2	28.4		
		75° F (78.6)	0° F (6.5)	140° 180° 220°	3	1.2	3.2	4.5	5.7	10.0	15.0	26.3	33.7
						1.2	3.0	4.3	5.4	9.6	14.3	25.2	32.2
						1.1	2.9	4.1	5.2	9.2	13.8	24.2	31.0
75° F (78.6)	40° F (35.1)			140° 180° 220°	3	1.3	3.4	4.8	6.1	10.9	16.2	28.5	36.5
						1.3	3.3	4.6	5.9	10.4	15.5	27.3	34.9
						1.2	3.1	4.4	5.7	10.0	14.9	26.2	33.6
		75° F (78.6)	40° F (35.1)	140° 180° 220°	6	1.9	4.8	6.8	8.7	15.3	22.9	40.2	51.4
						1.8	4.6	6.5	8.3	14.6	21.9	38.4	49.1
						1.7	4.4	6.3	8.0	14.1	21.0	36.9	47.2
95° F (113.8)	-40° F (14.7 in. hg)			140° 180° 220°	3	1.2	3.1	4.4	5.6	9.9	14.8	26.0	33.2
						1.2	3.0	4.2	5.3	9.4	14.0	24.7	31.6
						1.1	2.8	4.0	5.1	9.0	13.4	23.6	30.3
		95° F (113.8)	-40° F (14.7 in. hg)	140° 180° 220°	6	1.7	4.4	6.2	7.9	14.0	20.8	36.6	46.8
						1.6	4.2	5.9	7.5	13.3	19.8	34.8	44.5
						1.6	4.0	5.6	7.2	12.7	19.0	33.3	42.6
95° F (113.8)	0° F (6.5)			140° 180° 220°	3	1.3	3.4	4.8	6.2	10.9	16.3	28.7	36.7
						1.3	3.3	4.6	5.9	10.4	15.5	27.2	34.9
						1.2	3.1	4.4	5.6	9.9	14.8	26.1	33.4
		95° F (113.8)	0° F (6.5)	140° 180° 220°	6	1.9	4.8	6.8	8.7	15.4	23.0	40.4	51.7
						1.8	4.6	6.5	8.3	14.6	21.9	38.4	49.1
						1.7	4.4	6.2	7.9	14.0	20.9	36.8	47.1
95° F (113.8)	40° F (35.1)			140° 180° 220°	3	1.5	3.7	5.3	6.7	11.9	17.8	31.3	40.0
						1.4	3.6	5.0	6.4	11.3	16.9	29.7	38.0
						1.3	3.4	4.8	6.1	10.9	16.2	28.5	36.4
		95° F (113.8)	40° F (35.1)	140° 180° 220°	6	2.1	5.3	7.5	9.5	16.8	25.1	44.1	56.4
						2.0	5.0	7.1	9.0	16.0	23.8	41.9	53.6
						1.9	4.8	6.8	8.7	15.3	22.8	40.1	51.3
115° F (158.4)	-40° F (14.7 in. hg)			140° 180° 220°	3	1.3	3.3	4.6	5.9	10.4	15.6	27.4	35.1
						1.2	3.1	4.4	5.5	9.8	14.6	25.8	33.0
						1.2	2.9	4.1	5.3	9.4	14.0	24.5	31.4
		115° F (158.4)	-40° F (14.7 in. hg)	140° 180° 220°	6	1.8	4.6	6.6	8.4	14.8	22.0	38.7	49.6
						1.7	4.4	6.2	7.9	13.9	20.7	36.4	46.6
						1.6	4.1	5.9	7.5	13.2	19.7	34.7	44.3
115° F (158.4)	0° F (6.5)			140° 180° 220°	3	1.4	3.7	5.2	6.6	11.7	17.4	30.7	39.3
						1.4	3.5	4.9	6.2	11.0	16.4	28.8	36.9
						1.3	3.3	4.6	5.9	10.5	15.6	27.5	35.2
		115° F (158.4)	0° F (6.5)	140° 180° 220°	6	2.0	5.2	7.3	9.3	16.5	24.7	43.3	55.5
						1.9	4.9	6.9	8.8	15.5	23.2	40.7	52.1
						1.8	4.6	6.6	8.4	14.8	22.1	38.8	49.6
115° F (158.4)	40° F (6.5)			140° 180° 220°	3	1.6	4.0	5.7	7.3	12.9	19.2	33.8	43.3
						1.5	3.8	5.4	6.8	12.1	18.1	31.8	40.7
						1.4	3.6	5.1	6.5	11.5	17.2	30.3	38.7
		115° F (158.4)	40° F (6.5)	140° 180° 220°	6	2.2	5.7	8.1	10.3	18.2	27.2	47.8	61.1
						2.1	5.4	7.6	9.7	17.1	25.5	44.9	57.4
						2.0	5.1	7.2	9.2	16.3	24.3	42.7	54.7

A8 Discharge Capacities (Kilowatts)

R134a

Cond Temp (Sat Pres) bar	Evap Temp (Sat Pres) bar	Discharge Temp	Pres Drop bar	A8A 3/8" 9 mm	A8A 5/8" 15 mm	A8A 7/8" 22 mm	A81 1-1/8" 28 mm	A81 1-3/8" 35 mm	A82 1-5/8" 42 mm	A82 2-1/8" 54 mm	A82 2-5/8" 66 mm			
25° C (5.5)	-40° C (373 mm hg)	60°	0.2	3.9	10.0	14.1	18.0	31.8	47.4	83.4	106.7			
				80°	3.8	9.6	13.5	17.2	30.5	45.5	80.0	102.4		
				100°	3.6	9.2	13.1	16.6	29.4	43.9	77.2	98.8		
		25° C (5.5)	-20° C (91.4 mm hg)	60°	0.2	4.3	10.8	15.3	19.5	34.5	51.5	90.5	115.8	
						80°	4.1	10.4	14.7	18.7	33.1	49.4	86.9	111.2
						100°	3.9	10.0	14.2	18.1	31.9	47.7	83.8	107.3
25° C (5.5)	0° C (1.9)			60°	0.2	4.6	11.7	16.5	21.0	37.1	55.4	97.4	124.6	
						80°	4.4	11.2	15.8	20.2	35.6	53.2	93.5	119.7
						100°	4.2	10.8	15.3	19.4	34.4	51.3	90.2	115.5
		30° C (6.7)	-40° C (373 mm hg)	60°	0.2	4.1	10.3	14.6	18.6	32.9	49.0	86.2	110.4	
						80°	3.9	9.9	14.0	17.8	31.5	47.0	82.6	105.7
						100°	3.7	9.5	13.5	17.1	30.3	45.2	79.6	101.8
30° C (6.7)	-20° C (91.4 mm hg)			60°	0.2	4.4	11.3	15.9	20.2	35.8	53.4	94.0	120.3	
						80°	4.2	10.8	15.2	19.4	34.3	51.2	90.0	115.2
						100°	4.1	10.4	14.7	18.7	33.0	49.3	86.7	111.0
		30° C (6.7)	0° C (1.9)	60°	0.2	4.8	12.2	17.2	21.9	38.7	57.7	101.5	129.9	
						80°	4.6	11.6	16.4	20.9	37.0	55.3	97.2	124.4
						100°	4.4	11.2	15.8	20.2	35.7	53.2	93.6	119.8
35° C (7.8)	-40° C (373 mm hg)			60°	0.2	4.2	10.7	15.0	19.2	33.9	50.6	89.0	113.9	
						80°	4.0	10.2	14.4	18.3	32.4	48.3	85.0	108.7
						100°	3.8	9.8	13.8	17.6	31.1	46.4	81.7	104.5
		35° C (7.8)	-20° C (91.4 mm hg)	60°	0.2	4.6	11.7	16.5	21.0	37.1	55.4	97.4	124.7	
						80°	4.4	11.1	15.7	20.0	35.4	52.9	93.0	119.0
						100°	4.2	10.7	15.1	19.3	34.1	50.8	89.4	114.4
35° C (7.8)	0° C (1.9)			60°	0.2	5.0	12.6	17.8	22.7	40.2	60.0	105.5	135.1	
						80°	4.7	12.1	17.0	21.7	38.4	57.3	100.8	129.0
						100°	4.6	11.6	16.4	20.9	36.9	55.1	96.9	124.0
		35° C (7.8)	0° C (1.9)	60°	0.4	7.0	17.8	25.2	32.1	56.7	84.7	148.9	190.4	
						80°	6.7	17.0	24.1	30.7	54.2	80.9	142.1	181.8
						100°	6.4	16.3	23.1	29.5	52.1	77.7	136.6	174.7



A8 Discharge Capacities (Tons)

R404A

Cond Temp (Sat Pres) psig	Evap Temp (Sat Pres) psig	Discharge Temp	Pres Drop psi	A8A 3/8" 9 mm	A8A 5/8" 15 mm	A8A 7/8" 22 mm	A81 1-1/8" 28 mm	A81 1-3/8" 35 mm	A82 1-5/8" 42 mm	A82 2-1/8" 54 mm	A82 2-5/8" 66 mm	
75° F (161.2)	-40° F (2.7)	140°	3	1.2	3.2	4.5	5.7	10.1	15.1	26.5	33.9	
				180°	1.2	3.0	4.3	5.4	9.6	14.3	25.2	32.3
				220°	1.1	2.9	4.1	5.2	9.2	13.7	24.1	30.9
		140°	6	1.8	4.5	6.3	8.1	14.3	21.3	37.5	47.9	
				180°	1.7	4.3	6.0	7.7	13.6	20.2	35.6	45.5
				220°	1.6	4.1	5.8	7.3	13.0	19.4	34.1	43.6
75° F (161.2)	0° F (33.5)	140°	3	1.4	3.6	5.0	6.4	11.3	16.9	29.7	38.0	
				180°	1.3	3.4	4.8	6.1	10.8	16.0	28.2	36.1
				220°	1.3	3.2	4.6	5.8	10.3	15.4	27.0	34.6
		140°	6	2.0	5.0	7.1	9.0	16.0	23.9	41.9	53.7	
				180°	1.9	4.8	6.7	8.6	15.2	22.7	39.8	51.0
				220°	1.8	4.6	6.4	8.2	14.5	21.7	38.1	48.8
75° F (161.2)	40° F (86.4)	140°	3	1.5	3.9	5.5	7.0	12.4	18.5	32.6	41.7	
				180°	1.5	3.7	5.2	6.7	11.8	17.6	31.0	39.7
				220°	1.4	3.6	5.0	6.4	11.3	16.9	29.7	38.0
		140°	6	2.2	5.5	7.8	9.9	17.6	26.2	46.1	58.9	
				180°	2.1	5.2	7.4	9.4	16.7	24.9	43.8	56.0
				220°	2.0	5.0	7.1	9.0	16.0	23.8	41.9	53.6
95° F (219.4)	-40° F (2.7)	140°	3	1.3	3.2	4.6	5.8	10.3	15.3	27.0	34.5	
				180°	1.2	3.0	4.3	5.5	9.7	14.4	25.4	32.5
				220°	1.1	2.9	4.1	5.2	9.2	13.7	24.1	30.9
		140°	6	1.8	4.6	6.5	8.2	14.5	21.7	38.2	48.8	
				180°	1.7	4.3	6.1	7.7	13.7	20.4	35.9	45.9
				220°	1.6	4.1	5.8	7.3	13.0	19.4	34.1	43.6
95° F (219.4)	0° F (33.5)	140°	3	1.5	3.7	5.2	6.6	11.7	17.5	30.8	39.4	
				180°	1.4	3.5	4.9	6.2	11.0	16.4	28.9	37.1
				220°	1.3	3.3	4.7	5.9	10.5	15.6	27.5	35.2
		140°	6	2.0	5.2	7.4	9.4	16.6	24.7	43.5	55.7	
				180°	1.9	4.9	6.9	8.8	15.6	23.3	40.9	52.4
				220°	1.8	4.7	6.6	8.4	14.8	22.1	38.9	49.8
95° F (219.4)	40° F (86.4)	140°	3	1.6	4.1	5.8	7.4	13.1	19.5	34.3	43.9	
				180°	1.5	3.9	5.4	6.9	12.3	18.3	32.2	41.3
				220°	1.4	3.7	5.2	6.6	11.7	17.4	30.7	39.2
		140°	6	2.3	5.8	8.2	10.4	18.5	27.6	48.5	62.0	
				180°	2.1	5.5	7.7	9.8	17.4	25.9	45.6	58.3
				220°	2.0	5.2	7.3	9.3	16.5	24.6	43.3	55.4
115° F (290.4)	-40° F (2.7)	140°	3	1.2	3.2	4.5	5.7	10.0	15.0	26.4	33.7	
				180°	1.1	2.9	4.1	5.2	9.3	13.8	24.3	31.1
				220°	1.1	2.7	3.9	4.9	8.7	13.0	22.9	29.3
		140°	6	1.8	4.5	6.3	8.0	14.2	21.2	37.3	47.7	
				180°	1.6	4.1	5.8	7.4	13.1	19.5	34.4	44.0
				220°	1.5	3.9	5.5	7.0	12.3	18.4	32.3	41.4
115° F (290.4)	0° F (33.5)	140°	3	1.5	3.7	5.2	6.7	11.8	17.6	30.9	39.6	
				180°	1.3	3.4	4.8	6.1	10.9	16.2	28.5	36.5
				220°	1.3	3.2	4.5	5.8	10.2	15.3	26.9	34.4
		140°	6	2.1	5.2	7.4	9.4	16.7	24.9	43.8	56.0	
				180°	1.9	4.8	6.8	8.7	15.4	22.9	40.3	51.6
				220°	1.8	4.5	6.4	8.2	14.5	21.6	38.0	48.6
115° F (290.4)	40° F (86.4)	140°	3	1.7	4.2	5.9	7.6	13.4	20.0	35.1	45.0	
				180°	1.5	3.9	5.5	7.0	12.4	18.4	32.4	41.5
				220°	1.4	3.7	5.2	6.6	11.6	17.3	30.5	39.1
		140°	6	2.3	6.0	8.4	10.7	19.0	28.3	49.7	63.7	
				180°	2.2	5.5	7.7	9.9	17.5	26.1	45.8	58.7
				220°	2.0	5.2	7.3	9.3	16.4	24.5	43.1	55.2



A8 Discharge Capacities (Kilowatts)

R404A

Cond Temp (Sat Pres) bar	Evap Temp (Sat Pres) bar	Discharge Temp	Pres Drop bar	A8A 3/8" 9 mm	A8A 5/8" 15 mm	A8A 7/8" 22 mm	A81 1-1/8" 28 mm	A81 1-3/8" 35 mm	A82 1-5/8" 42 mm	A82 2-1/8" 54 mm	A82 2-5/8" 66 mm	
25° C (11.2)	-40° C (0.3)	60°	0.2	4.3	10.9	15.4	19.6	34.7	51.7	91.0	116.5	
		80°		4.1	10.4	14.7	18.7	33.1	49.4	86.8	111.2	
		100°		3.9	10.0	14.1	17.9	31.8	47.4	83.4	106.8	
	25° C (11.2)	-20° C (2.0)	60°	0.4	6.0	15.4	21.7	27.7	49.0	73.1	128.5	164.5
			80°		5.8	14.7	20.7	26.4	46.7	69.7	122.6	156.9
			100°		5.5	14.1	19.9	25.4	44.9	66.9	117.7	150.6
25° C (11.2)		0° C (4.9)	60°	0.2	4.8	12.1	17.1	21.7	38.5	57.4	101.1	129.4
			80°		4.5	11.6	16.3	20.8	36.8	54.8	96.4	123.5
			100°		4.4	11.1	15.6	19.9	35.3	52.6	92.6	118.5
	25° C (11.2)	0° C (4.9)	60°	0.4	6.7	17.1	24.1	30.8	54.4	81.2	142.7	182.7
			80°		6.4	16.3	23.0	29.4	51.9	77.4	136.2	174.2
			100°		6.1	15.6	22.1	28.2	49.8	74.3	130.7	167.3
30° C (13.1)		-40° C (0.3)	60°	0.2	5.2	13.2	18.7	23.8	42.1	62.8	110.4	141.4
			80°		5.0	12.6	17.8	22.7	40.2	59.9	105.4	134.9
			100°		4.8	12.1	17.1	21.8	38.6	57.5	101.2	129.5
	30° C (13.1)	-20° C (2.0)	60°	0.4	7.3	18.7	26.4	33.6	59.5	88.7	156.0	199.6
			80°		7.0	17.8	25.2	32.1	56.7	84.6	148.8	190.4
			100°		6.7	17.1	24.2	30.8	54.4	81.2	142.8	182.8
30° C (13.1)		0° C (4.9)	60°	0.2	4.3	11.0	15.5	19.8	35.0	52.2	91.8	117.5
			80°		4.1	10.5	14.7	18.8	33.3	49.6	87.3	111.7
			100°		3.9	10.0	14.1	18.0	31.9	47.5	83.6	107.0
	30° C (13.1)	-20° C (2.0)	60°	0.4	6.1	15.5	21.9	28.0	49.4	73.8	129.7	166.0
			80°		5.8	14.8	20.8	26.6	47.0	70.1	123.3	157.8
			100°		5.5	14.1	20.0	25.4	45.0	67.1	118.0	151.1
30° C (13.1)		0° C (4.9)	60°	0.2	4.8	12.3	17.3	22.1	39.1	58.4	102.7	131.5
			80°		4.6	11.7	16.5	21.0	37.2	55.5	97.6	125.0
			100°		4.4	11.2	15.8	20.1	35.6	53.1	93.5	119.7
	35° C (15.1)	-40° C (0.3)	60°	0.4	6.8	17.4	24.5	31.3	55.3	82.5	145.1	185.7
			80°		6.5	16.5	23.3	29.7	52.6	78.4	137.9	176.5
			100°		6.2	15.8	22.3	28.5	50.3	75.1	132.0	169.0
35° C (15.1)		-20° C (2.0)	60°	0.2	5.3	13.5	19.1	24.3	43.0	64.1	112.9	144.5
			80°		5.1	12.9	18.1	23.1	40.9	61.0	107.3	137.4
			100°		4.8	12.3	17.4	22.1	39.2	58.4	102.8	131.5
	35° C (15.1)	0° C (4.9)	60°	0.4	7.5	19.1	27.0	34.4	60.8	90.7	159.5	204.1
			80°		7.1	18.1	25.6	32.7	57.8	86.2	151.5	193.9
			100°		6.8	17.4	24.5	31.3	55.3	82.5	145.1	185.7
35° C (15.1)		-40° C (0.3)	60°	0.2	4.3	11.0	15.6	19.8	35.1	52.3	92.1	117.9
			80°		4.1	10.4	14.7	18.7	33.2	49.5	87.1	111.5
			100°		3.9	10.0	14.0	17.9	31.7	47.3	83.2	106.5
	35° C (15.1)	-20° C (2.0)	60°	0.4	6.1	15.6	22.0	28.1	49.6	74.0	130.2	166.7
			80°		5.8	14.7	20.8	26.5	46.9	70.0	123.1	157.6
			100°		5.5	14.1	19.9	25.3	44.8	66.8	117.5	150.4
35° C (15.1)		0° C (4.9)	60°	0.2	4.9	12.4	17.5	22.3	39.6	59.0	103.9	133.0
			80°		4.6	11.8	16.6	21.1	37.5	55.8	98.3	125.8
			100°		4.4	11.2	15.8	20.2	35.8	53.3	93.8	120.1
	35° C (15.1)	0° C (4.9)	60°	0.4	6.9	17.6	24.8	31.7	56.0	83.5	146.9	188.1
			80°		6.5	16.6	23.5	29.9	52.9	79.0	138.9	177.8
			100°		6.2	15.9	22.4	28.6	50.5	75.4	132.6	169.7
35° C (15.1)		0° C (4.9)	60°	0.2	5.4	13.8	19.4	24.7	43.8	65.3	114.9	147.1
			80°		5.1	13.0	18.4	23.4	41.4	61.8	108.7	139.2
			100°		4.9	12.4	17.5	22.3	39.6	59.0	103.8	132.9
	35° C (15.1)	0° C (4.9)	60°	0.4	7.6	19.5	27.5	35.0	61.9	92.4	162.5	208.0
			80°		7.2	18.4	26.0	33.1	58.6	87.4	153.7	196.7
			100°		6.9	17.6	24.8	31.6	55.9	83.4	146.7	187.7

A8 Discharge Capacities (Tons)

R507

Cond Temp (Sat Pres) psig	Evap Temp (Sat Pres) psig	Discharge Temp	Pres Drop psi	A8A 3/8" 9 mm	A8A 5/8" 15 mm	A8A 7/8" 22 mm	A81 1-1/8" 28 mm	A81 1-3/8" 35 mm	A82 1-5/8" 42 mm	A82 2-1/8" 54 mm	A82 2-5/8" 66 mm	
75° F (167.0)	-40° F (5.5)	140°	3	1.3	3.2	4.5	5.8	10.2	15.2	26.8	34.3	
			180°	1.2	3.1	4.3	5.5	9.7	14.5	25.5	32.6	
			220°	1.2	2.9	4.1	5.3	9.3	13.9	24.4	31.2	
		140°	6	180°	1.8	4.5	6.4	8.2	14.4	21.5	37.8	48.4
				180°	1.7	4.3	6.1	7.8	13.7	20.5	36.0	46.0
				220°	1.6	4.1	5.8	7.4	13.1	19.6	34.4	44.1
75° F (167.0)	0° F (35.2)	140°	3	1.4	3.6	5.0	6.4	11.4	16.9	29.8	38.2	
			180°	1.3	3.4	4.8	6.1	10.8	16.1	28.3	36.3	
			220°	1.3	3.3	4.6	5.8	10.3	15.4	27.1	34.8	
		140°	6	180°	2.0	5.0	7.1	9.1	16.0	23.9	42.1	53.9
				180°	1.9	4.8	6.8	8.6	15.2	22.8	40.0	51.2
				220°	1.8	4.6	6.5	8.3	14.6	21.8	38.3	49.0
75° F (167.0)	40° F (89.8)	140°	3	1.5	3.9	5.5	7.0	12.4	18.6	32.7	41.8	
			180°	1.5	3.7	5.2	6.7	11.8	17.6	31.0	39.7	
			220°	1.4	3.6	5.0	6.4	11.3	16.9	29.7	38.1	
		140°	6	180°	2.2	5.5	7.8	9.9	17.6	26.2	46.1	59.0
				180°	2.1	5.2	7.4	9.4	16.7	24.9	43.8	56.1
				220°	2.0	5.0	7.1	9.0	16.0	23.9	42.0	53.7
95° F (226.0)	-40° F (5.5)	140°	3	1.3	3.3	4.7	6.0	10.6	15.7	27.7	35.5	
			180°	1.2	3.1	4.4	5.6	9.9	14.8	26.1	33.4	
			220°	1.2	3.0	4.2	5.3	9.5	14.1	24.8	31.8	
		140°	6	180°	1.8	4.7	6.6	8.4	14.9	22.2	39.1	50.1
				180°	1.7	4.4	6.2	7.9	14.0	20.9	36.8	47.1
				220°	1.6	4.2	5.9	7.6	13.4	19.9	35.1	44.9
95° F (226.0)	0° F (35.2)	140°	3	1.5	3.7	5.3	6.7	11.9	17.8	31.3	40.1	
			180°	1.4	3.5	5.0	6.3	11.2	16.7	29.5	37.7	
			220°	1.3	3.4	4.7	6.0	10.7	15.9	28.1	35.9	
		140°	6	180°	2.1	5.3	7.5	9.5	16.9	25.1	44.2	56.6
				180°	2.0	5.0	7.0	9.0	15.9	23.7	41.6	53.3
				220°	1.9	4.7	6.7	8.5	15.1	22.5	39.6	50.7
95° F (226.0)	40° F (89.8)	140°	3	1.6	4.2	5.9	7.5	13.2	19.7	34.7	44.4	
			180°	1.5	3.9	5.5	7.0	12.4	18.6	32.7	41.8	
			220°	1.5	3.7	5.3	6.7	11.9	17.7	31.1	39.8	
		140°	6	180°	2.3	5.9	8.3	10.6	18.7	27.9	49.0	62.7
				180°	2.2	5.5	7.8	9.9	17.6	26.2	46.1	59.0
				220°	2.1	5.3	7.4	9.5	16.7	25.0	43.9	56.2
115° F (301.0)	-40° F (5.5)	140°	3	1.3	3.3	4.7	6.0	10.6	15.8	27.8	35.7	
			180°	1.2	3.1	4.4	5.5	9.8	14.6	25.8	33.0	
			220°	1.1	2.9	4.1	5.2	9.3	13.8	24.3	31.1	
		140°	6	180°	1.9	4.7	6.7	8.5	15.0	22.4	39.4	50.4
				180°	1.7	4.4	6.2	7.8	13.9	20.7	36.4	46.6
				220°	1.6	4.1	5.8	7.4	13.1	19.5	34.4	44.0
115° F (301.0)	0° F (35.2)	140°	3	1.5	3.9	5.4	6.9	12.3	18.3	32.2	41.2	
			180°	1.4	3.6	5.0	6.4	11.3	16.9	29.8	38.1	
			220°	1.3	3.4	4.7	6.0	10.7	16.0	28.1	36.0	
		140°	6	180°	2.1	5.5	7.7	9.8	17.4	25.9	45.6	58.3
				180°	2.0	5.0	7.1	9.1	16.0	23.9	42.1	53.9
				220°	1.9	4.8	6.7	8.5	15.1	22.6	39.7	50.8
115° F (301.0)	40° F (89.8)	140°	3	1.7	4.3	6.1	7.8	13.8	20.6	36.3	46.5	
			180°	1.6	4.0	5.7	7.2	12.8	19.1	33.6	43.0	
			220°	1.5	3.8	5.3	6.8	12.1	18.0	31.7	40.6	
		140°	6	180°	2.4	6.1	8.7	11.1	19.6	29.2	51.3	65.7
				180°	2.2	5.7	8.0	10.2	18.1	27.0	47.5	60.7
				220°	2.1	5.4	7.6	9.6	17.1	25.4	44.8	57.3

A8 Discharge Capacities (Kilowatts)

R507

Cond Temp (Sat Pres) bar	Evap Temp (Sat Pres) bar	Discharge Temp	Pres Drop bar	A8A	A8A	A8A	A81	A81	A82	A82	A82		
				3/8" 9 mm	5/8" 15 mm	7/8" 22 mm	1-1/8" 28 mm	1-3/8" 35 mm	1-5/8" 42 mm	2-1/8" 54 mm	2-5/8" 66 mm		
25° C (11.6)	-40° C (0.4)	60° 80° 100°	0.2	4.3	11.0	15.6	19.8	35.1	52.3	92.1	117.9		
				4.1	10.5	14.9	18.9	33.5	50.0	87.9	112.6		
				4.0	10.1	14.3	18.2	32.2	48.0	84.5	108.1		
		25° C (11.6)	-20° C (2.1)	60° 80° 100°	0.4	6.1	15.6	22.0	28.0	49.6	74.0	130.1	166.5
						5.8	14.9	21.0	26.8	47.3	70.6	124.1	158.8
						5.6	14.3	20.2	25.7	45.4	67.8	119.3	152.6
25° C (11.6)	0° C (5.2)			60° 80° 100°	0.2	4.8	12.2	17.2	21.9	38.7	57.8	101.6	130.1
						4.6	11.6	16.4	20.9	37.0	55.1	97.0	124.2
						4.4	11.2	15.8	20.1	35.5	53.0	93.2	119.4
		25° C (11.6)	0° C (5.2)	60° 80° 100°	0.4	6.7	17.2	24.3	30.9	54.7	81.7	143.6	183.7
						6.4	16.4	23.2	29.5	52.2	77.9	137.0	175.3
						6.2	15.8	22.3	28.4	50.2	74.9	131.6	168.4
30° C (13.5)	-40° C (0.4)			60° 80° 100°	0.2	4.4	11.2	15.8	20.1	35.7	53.2	93.6	119.8
						4.2	10.7	15.0	19.2	33.9	50.6	89.0	114.0
						4.0	10.2	14.4	18.4	32.5	48.5	85.3	109.3
		30° C (13.5)	-20° C (2.1)	60° 80° 100°	0.4	6.2	15.8	22.4	28.5	50.4	75.2	132.3	169.3
						5.9	15.1	21.3	27.1	47.9	71.5	125.7	160.9
						5.7	14.4	20.4	26.0	45.9	68.5	120.5	154.2
30° C (13.5)	0° C (5.2)			60° 80° 100°	0.2	4.9	12.4	17.6	22.4	39.6	59.1	103.9	133.0
						4.7	11.8	16.7	21.3	37.7	56.2	98.8	126.5
						4.5	11.4	16.0	20.4	36.1	53.8	94.8	121.3
		30° C (13.5)	0° C (5.2)	60° 80° 100°	0.4	6.9	17.6	24.8	31.6	56.0	83.5	146.9	187.9
						6.6	16.7	23.6	30.1	53.2	79.4	139.6	178.7
						6.3	16.0	22.6	28.8	51.0	76.1	133.8	171.3
35° C (15.6)	-40° C (0.4)			60° 80° 100°	0.2	5.4	13.6	19.2	24.5	43.3	64.6	113.7	145.6
						5.1	13.0	18.3	23.3	41.2	61.5	108.2	138.5
						4.9	12.4	17.5	22.3	39.5	58.9	103.7	132.8
		35° C (15.6)	-20° C (2.1)	60° 80° 100°	0.4	7.6	19.2	27.2	34.6	61.3	91.4	160.7	205.7
						7.2	18.3	25.8	32.9	58.2	86.9	152.8	195.6
						6.9	17.5	24.8	31.6	55.8	83.3	146.5	187.4
35° C (15.6)	0° C (5.2)			60° 80° 100°	0.2	4.5	11.3	16.0	20.4	36.1	53.8	94.6	121.1
						4.2	10.7	15.1	19.3	34.1	50.9	89.6	114.7
						4.0	10.3	14.5	18.4	32.6	48.7	85.6	109.6
		35° C (15.6)	0° C (5.2)	60° 80° 100°	0.4	6.3	16.0	22.6	28.8	51.0	76.0	133.7	171.1
						6.0	15.1	21.4	27.3	48.2	71.9	126.5	161.9
						5.7	14.5	20.4	26.0	46.1	68.7	120.9	154.8
35° C (15.6)	-20° C (2.1)			60° 80° 100°	0.2	5.0	12.7	17.9	22.8	40.3	60.1	105.8	135.5
						4.7	12.0	16.9	21.5	38.2	56.9	100.2	128.2
						4.5	11.5	16.2	20.6	36.5	54.4	95.8	122.6
		35° C (15.6)	-20° C (2.1)	60° 80° 100°	0.4	7.0	17.9	25.3	32.2	57.0	85.0	149.5	191.4
						6.7	16.9	23.9	30.5	53.9	80.4	141.5	181.1
						6.4	16.2	22.9	29.1	51.5	76.9	135.2	173.1
35° C (15.6)	0° C (5.2)			60° 80° 100°	0.2	5.5	13.9	19.7	25.0	44.4	66.2	116.4	149.1
						5.2	13.2	18.6	23.7	42.0	62.6	110.2	141.1
						5.0	12.6	17.8	22.7	40.2	59.9	105.4	134.9
		35° C (15.6)	0° C (5.2)	60° 80° 100°	0.4	7.7	19.7	27.8	35.4	62.7	93.5	164.5	210.6
						7.3	18.6	26.3	33.5	59.3	88.5	155.7	199.3
						7.0	17.8	25.2	32.1	56.7	84.6	148.8	190.5

CK4A Hot Gas Discharge Capacities - Tons R22 Refrigeration & Air Conditioning Control Valves

CK4A Hot Gas Discharge Capacities (Tons)

R22

Cond Temp (Sat Pres) psig	Evap Temp (Sat Pres) psig	Discharge Temp	Pres Drop psi	1/2" 13 mm	3/4" 20 mm	1" 25 mm	1-1/4" 32 mm	2" 50 mm	2-1/2" 65 mm	3" 75 mm	4" 100 mm		
75° F (132)	-40° F (0.5)	140°	0.75	1.7	3.5	6.4	9.4	22.8	34.7	55.5	104.0		
		180°		1.6	3.4	6.2	9.0	21.8	33.1	53.0	99.4		
		220°		1.5	3.2	5.9	8.6	20.9	31.9	51.0	95.6		
		75° F (132)	0° F (24.0)	140°	3	3.4	7.0	12.8	18.8	45.4	69.1	110.6	207.4
				180°		3.2	6.7	12.3	17.9	43.4	66.0	105.7	198.1
				220°		3.1	6.4	11.8	17.2	41.7	63.5	101.5	190.4
75° F (132)	40° F (68.5)			140°	0.75	1.9	3.9	7.2	10.5	25.4	38.6	61.7	115.7
				180°		1.8	3.7	6.8	10.0	24.2	36.9	59.0	110.6
				220°		1.7	3.6	6.6	9.6	23.3	35.4	56.7	106.3
		95° F (182)	-40° F (0.5)	140°	3	3.7	7.8	14.3	20.9	50.5	76.9	123.0	230.7
				180°		3.6	7.5	13.6	19.9	48.3	73.5	117.5	220.4
				220°		3.4	7.2	13.1	19.2	46.4	70.6	113.0	211.8
95° F (182)	0° F (24.0)			140°	0.75	1.8	3.8	7.0	10.2	24.8	37.7	60.4	113.2
				180°		1.7	3.6	6.7	9.7	23.5	35.8	57.3	107.5
				220°		1.7	3.5	6.4	9.3	22.5	34.3	54.9	102.9
		95° F (182)	40° F (68.5)	140°	3	3.7	7.6	14.0	20.4	49.5	75.3	120.4	225.8
				180°		3.5	7.2	13.3	19.4	46.9	71.4	114.3	214.3
				220°		3.3	6.9	12.7	18.6	44.9	68.4	109.4	205.1
115° F (243)	-40° F (0.5)			140°	0.75	2.0	4.1	7.5	10.9	26.4	40.2	64.3	120.5
				180°		1.9	3.9	7.1	10.4	25.1	38.1	61.0	114.4
				220°		1.8	3.7	6.8	9.9	24.0	36.5	58.4	109.5
		115° F (243)	0° F (24.0)	140°	3	3.9	8.1	14.9	21.8	52.7	80.2	128.3	240.5
				180°		3.7	7.7	14.1	20.7	50.0	76.1	121.7	228.2
				220°		3.5	7.4	13.5	19.8	47.8	72.8	116.5	218.4
115° F (243)	40° F (68.5)			140°	0.75	2.1	4.3	7.9	11.5	27.8	42.4	67.8	127.1
				180°		2.0	4.1	7.5	10.9	26.4	40.2	64.3	120.6
				220°		1.9	3.9	7.1	10.4	25.3	38.5	61.6	115.5
		115° F (243)	-40° F (0.5)	140°	3	4.1	8.6	15.7	22.9	55.5	84.5	135.2	253.5
				180°		3.9	8.1	14.9	21.8	52.7	80.2	128.3	240.6
				220°		3.7	7.8	14.3	20.8	50.4	76.7	122.8	230.2
115° F (243)	0° F (24.0)			140°	0.75	2.1	4.4	8.1	11.8	28.6	43.5	69.6	130.5
				180°		2.0	4.1	7.6	11.1	26.8	40.8	65.3	122.5
				220°		1.9	3.9	7.2	10.5	25.5	38.8	62.1	116.5
		115° F (243)	40° F (68.5)	140°	3	4.2	8.8	16.1	23.6	57.1	86.8	138.9	260.5
				180°		4.0	8.3	15.1	22.1	53.6	81.5	130.4	244.5
				220°		3.8	7.9	14.4	21.0	50.9	77.5	124.0	232.5
115° F (243)	-40° F (0.5)			140°	0.75	2.2	4.7	8.6	12.5	30.3	46.1	73.7	138.2
				180°		2.1	4.4	8.0	11.7	28.4	43.2	69.2	129.7
				220°		2.0	4.2	7.6	11.2	27.0	41.1	65.8	123.4
		115° F (243)	0° F (24.0)	140°	3	4.5	9.3	17.1	25.0	60.4	92.0	147.2	276.0
				180°		4.2	8.8	16.0	23.4	56.7	86.3	138.1	259.0
				220°		4.0	8.3	15.2	22.3	53.9	82.1	131.3	246.3



CK4A Hot Gas Discharge Capacities (Kilowatts)

R22

Cond Temp (Sat Pres) bar	Evap Temp (Sat Pres) bar	Discharge Temp	Pres Drop bar	1/2" 13 mm	3/4" 20 mm	1" 25 mm	1-1/4" 32 mm	2" 50 mm	2-1/2" 65 mm	3" 75 mm	4" 100 mm		
25° C (9.2)	-40° C (0.0)	60°	0.05	5.8	12.2	22.3	32.7	79.1	120.3	192.5	360.9		
		80°		5.6	11.7	21.4	31.3	75.8	115.4	184.7	346.2		
		100°		5.4	11.3	20.7	30.2	73.1	111.3	178.0	333.8		
	25° C (9.2)	-20° C (1.4)	60°	0.21	11.9	24.9	45.6	66.7	161.4	245.6	392.9	736.7	
			80°		11.4	23.9	43.7	63.9	154.8	235.5	376.8	706.5	
			100°		11.0	23.0	42.2	61.6	149.2	227.0	363.2	681.0	
		25° C (9.2)	0° C (4.0)	60°	0.05	6.4	13.5	24.7	36.0	87.3	132.8	212.5	398.3
				80°		6.2	12.9	23.7	34.6	83.7	127.4	203.8	382.1
				100°		6.0	12.5	22.8	33.3	80.7	122.8	196.5	368.4
30° C (10.9)			-40° C (0.0)	60°	0.21	13.2	27.5	50.3	73.6	178.1	271.0	433.6	813.0
				80°		12.6	26.4	48.3	70.5	170.8	259.9	415.8	779.7
				100°		12.2	25.4	46.5	68.0	164.6	250.5	400.8	751.5
	30° C (10.9)		-20° C (1.4)	60°	0.05	6.1	12.7	23.2	33.9	82.2	125.0	200.1	375.1
				80°		5.8	12.1	22.2	32.5	78.6	119.6	191.4	358.9
				100°		5.6	11.7	21.4	31.3	75.7	115.1	184.2	345.4
		30° C (10.9)	0° C (4.0)	60°	0.21	12.4	25.9	47.4	69.3	167.8	255.4	408.7	766.2
				80°		11.9	24.8	45.4	66.3	160.6	244.3	390.9	733.0
				100°		11.4	23.8	43.7	63.8	154.5	235.1	376.2	705.3
35° C (12.6)			-40° C (0.0)	60°	0.05	6.4	13.4	24.5	35.9	86.8	132.1	211.4	396.4
				80°		6.1	12.8	23.5	34.3	83.1	126.4	202.3	379.2
				100°		5.9	12.3	22.6	33.0	80.0	121.7	194.7	365.0
	35° C (12.6)		-20° C (1.4)	60°	0.21	13.1	27.4	50.1	73.2	177.3	269.9	431.8	809.6
				80°		12.5	26.2	47.9	70.1	169.6	258.1	413.0	774.4
				100°		12.1	25.2	46.1	67.4	163.2	248.4	397.4	745.2
		35° C (12.6)	0° C (4.0)	60°	0.05	6.7	14.0	25.7	37.6	91.0	138.5	221.6	415.5
				80°		6.4	13.4	24.6	36.0	87.1	132.5	212.0	397.6
				100°		6.2	12.9	23.7	34.6	83.8	127.5	204.1	382.6
35° C (12.6)			-40° C (0.0)	60°	0.21	13.7	28.7	52.5	76.8	185.9	282.9	452.6	848.7
				80°		13.1	27.4	50.3	73.5	177.8	270.6	433.0	811.9
				100°		12.6	26.4	48.4	70.7	171.1	260.4	416.6	781.2
	35° C (12.6)		-20° C (1.4)	60°	0.05	6.3	13.1	24.1	35.2	85.2	129.6	207.4	388.9
				80°		6.0	12.5	23.0	33.6	81.3	123.7	197.8	371.0
				100°		5.8	12.0	22.1	32.2	78.0	118.8	190.0	356.3
		35° C (12.6)	0° C (4.0)	60°	0.21	12.9	26.9	49.2	71.9	174.1	265.0	424.0	795.0
				80°		12.3	25.6	46.9	68.6	166.1	252.7	404.3	758.1
				100°		11.8	24.6	45.1	65.9	159.5	242.7	388.3	728.0
35° C (12.6)			-20° C (1.4)	60°	0.05	6.7	13.9	25.5	37.3	90.2	137.3	219.6	411.8
				80°		6.4	13.3	24.3	35.5	86.0	130.9	209.5	392.8
				100°		6.1	12.8	23.4	34.1	82.6	125.8	201.2	377.3
	35° C (12.6)		0° C (4.0)	60°	0.21	13.6	28.5	52.1	76.2	184.4	280.6	449.0	841.8
				80°		13.0	27.1	49.7	72.6	175.8	267.6	428.1	802.8
				100°		12.5	26.1	47.7	69.7	168.9	257.0	411.1	770.9
		35° C (12.6)	-40° C (0.0)	60°	0.05	7.0	14.6	26.8	39.1	94.7	144.2	230.7	432.5
				80°		6.7	13.9	25.5	37.3	90.4	137.5	220.0	412.5
				100°		6.4	13.4	24.5	35.8	86.8	132.1	211.3	396.2
35° C (12.6)			-20° C (1.4)	60°	0.21	14.3	29.9	54.7	80.0	193.7	294.7	471.5	884.1
				80°		13.6	28.5	52.2	76.3	184.7	281.0	449.6	843.1
				100°		13.1	27.4	50.1	73.2	177.3	269.9	431.8	809.6



CK4A Hot Gas Discharge Capacities (Tons)

R134a

Cond Temp (Sat Pres) psig	Evap Temp (Sat Pres) psig	Discharge Temp	Pres Drop psi	1/2" 13 mm	3/4" 20 mm	1" 25 mm	1-1/4" 32 mm	2" 50 mm	2-1/2" 65 mm	3" 75 mm	4" 100 mm
75° F (78.6)	-40° F (14.7 in hg)	140°	0.75	1.3	2.7	4.9	7.2	17.5	26.6	42.6	79.9
		180°		1.2	2.6	4.7	6.9	16.7	25.5	40.8	76.5
		220°		1.2	2.5	4.6	6.7	16.1	24.5	39.2	73.6
		140°	3	2.6	5.4	9.8	14.4	34.8	52.9	84.6	158.7
		180°		2.5	5.1	9.4	13.7	33.2	50.6	80.9	151.8
		220°		2.4	4.9	9.0	13.2	32.0	48.7	77.9	146.0
75° F (78.6)	0° F (6.5)	140°	0.75	1.4	3.0	5.4	7.9	19.1	29.1	46.6	87.4
		180°		1.4	2.8	5.2	7.6	18.3	27.9	44.6	83.6
		220°		1.3	2.7	5.0	7.3	17.6	26.8	42.9	80.5
		140°	3	2.8	5.9	10.7	15.7	38.0	57.8	92.5	173.5
		180°		2.7	5.6	10.3	15.0	36.4	55.3	88.5	165.9
		220°		2.6	5.4	9.9	14.4	35.0	53.2	85.1	159.6
75° F (78.6)	40° F (35.1)	140°	0.75	1.5	3.2	5.9	8.6	20.7	31.5	50.4	94.6
		180°		1.5	3.1	5.6	8.2	19.8	30.2	48.3	90.5
		220°		1.4	2.9	5.4	7.9	19.1	29.0	46.4	87.1
		140°	3	3.0	6.3	11.6	17.0	41.1	62.6	100.1	187.8
		180°		2.9	6.1	11.1	16.2	39.3	59.9	95.8	179.6
		220°		2.8	5.8	10.7	15.6	37.8	57.6	92.1	172.8
95° F (113.8)	-40° F (14.7 in hg)	140°	0.75	1.4	2.9	5.3	7.8	18.8	28.7	45.9	86.0
		180°		1.3	2.8	5.1	7.4	17.9	27.3	43.6	81.8
		220°		1.3	2.7	4.9	7.1	17.2	26.1	41.8	78.4
		140°	3	2.8	5.8	10.6	15.5	37.5	57.1	91.3	171.2
		180°		2.6	5.5	10.1	14.7	35.6	54.2	86.8	162.7
		220°		2.5	5.3	9.7	14.1	34.2	52.0	83.2	155.9
95° F (113.8)	0° F (6.5)	140°	0.75	1.5	3.2	5.9	8.6	20.8	31.7	50.7	95.0
		180°		1.5	3.1	5.6	8.2	19.8	30.1	48.2	90.3
		220°		1.4	2.9	5.4	7.8	19.0	28.9	46.2	86.6
		140°	3	3.1	6.4	11.7	17.1	41.4	63.0	100.8	189.1
		180°		2.9	6.1	11.1	16.3	39.4	59.9	95.8	179.7
		220°		2.8	5.8	10.7	15.6	37.7	57.4	91.8	172.2
95° F (113.8)	40° F (35.1)	140°	0.75	1.7	3.5	6.4	9.4	22.7	34.6	55.3	103.7
		180°		1.6	3.3	6.1	8.9	21.6	32.9	52.6	98.6
		220°		1.5	3.2	5.8	8.5	20.7	31.5	50.4	94.5
		140°	3	3.3	7.0	12.8	18.7	45.2	68.8	110.0	206.3
		180°		3.2	6.6	12.1	17.7	42.9	65.3	104.6	196.0
		220°		3.0	6.4	11.6	17.0	41.1	62.6	100.2	187.8
115° F (158.4)	-40° F (14.7 in hg)	140°	0.75	1.5	3.1	5.6	8.2	19.9	30.3	48.4	90.8
		180°		1.4	2.9	5.3	7.7	18.7	28.5	45.6	85.4
		220°		1.3	2.8	5.0	7.4	17.8	27.1	43.4	81.4
		140°	3	2.9	6.1	11.2	16.4	39.7	60.3	96.5	181.0
		180°		2.8	5.8	10.5	15.4	37.3	56.7	90.8	170.2
		220°		2.6	5.5	10.0	14.7	35.5	54.0	86.5	162.1
115° F (158.4)	0° F (6.5)	140°	0.75	1.6	3.4	6.3	9.2	22.2	33.9	54.2	101.6
		180°		1.5	3.2	5.9	8.6	20.9	31.8	51.0	95.5
		220°		1.5	3.1	5.6	8.2	19.9	30.3	48.5	91.0
		140°	3	3.3	6.8	12.5	18.3	44.4	67.5	108.0	202.5
		180°		3.1	6.4	11.8	17.2	41.7	63.5	101.5	190.4
		220°		2.9	6.1	11.2	16.4	39.7	60.4	96.7	181.3
115° F (158.4)	40° F (35.1)	140°	0.75	1.8	3.8	6.9	10.1	24.5	37.3	59.7	111.9
		180°		1.7	3.6	6.5	9.5	23.1	35.1	56.2	105.3
		220°		1.6	3.4	6.2	9.1	22.0	33.4	53.5	100.3
		140°	3	3.6	7.5	13.8	20.2	48.9	74.4	119.0	223.1
		180°		3.4	7.1	13.0	19.0	46.0	69.9	111.9	209.8
		220°		3.2	6.8	12.4	18.1	43.8	66.6	106.6	199.8

CK4A Hot Gas Discharge Capacities (Kilowatts)

R134a

Cond Temp (Sat Pres) bar	Evap Temp (Sat Pres) bar	Discharge Temp	Pres Drop bar	1/2" 13 mm	3/4" 20 mm	1" 25 mm	1-1/4" 32 mm	2" 50 mm	2-1/2" 65 mm	3" 75 mm	4" 100 mm			
25° C (5.5)	-40° C (373 mm hg)	60°	0.05	4.5	9.3	17.1	25.0	60.6	92.2	147.4	276.5			
				80°	4.3	9.0	16.4	24.0	58.2	88.5	141.6	265.5		
				100°	4.1	8.7	15.9	23.2	56.1	85.4	136.6	256.2		
		25° C (5.5)	-20° C (91.4 mm hg)	60°	0.05	9.1	19.0	34.8	50.9	123.2	187.5	300.1	562.6	
						80°	8.7	18.3	33.4	48.9	118.3	180.0	288.1	540.1
						100°	8.4	17.6	32.3	47.1	114.1	173.7	277.9	521.1
25° C (5.5)	0° C (1.9)			60°	0.05	4.9	10.1	18.6	27.2	65.7	100.0	160.1	300.1	
						80°	4.7	9.7	17.8	26.1	63.1	96.1	153.7	288.2
						100°	4.5	9.4	17.2	25.2	60.9	92.7	148.3	278.1
		25° C (5.5)	0° C (1.9)	60°	0.21	9.9	20.7	37.8	55.3	133.8	203.6	325.8	610.8	
						80°	9.5	19.8	36.3	53.1	128.4	195.5	312.7	586.4
						100°	9.2	19.1	35.0	51.2	123.9	188.6	301.7	565.7
30° C (6.7)	-40° C (373 mm hg)			60°	0.05	5.2	10.9	20.0	29.2	70.8	107.7	172.3	323.0	
						80°	5.0	10.5	19.2	28.1	67.9	103.4	165.4	310.2
						100°	4.8	10.1	18.5	27.1	65.6	99.8	159.6	299.3
		30° C (6.7)	-20° C (91.4 mm hg)	60°	0.21	10.6	22.2	40.7	59.5	144.0	219.1	350.6	657.4	
						80°	10.2	21.3	39.1	57.1	138.2	210.4	336.6	631.1
						100°	9.9	20.6	37.7	55.1	133.4	203.0	324.7	608.9
30° C (6.7)	-40° C (373 mm hg)			60°	0.05	4.6	9.7	17.7	25.9	62.7	95.3	152.5	286.0	
						80°	4.4	9.3	17.0	24.8	60.0	91.3	146.1	274.0
						100°	4.3	8.9	16.3	23.9	57.8	88.0	140.8	264.0
		30° C (6.7)	-20° C (91.4 mm hg)	60°	0.21	9.4	19.7	36.1	52.7	127.6	194.2	310.7	582.5	
						80°	9.0	18.9	34.5	50.5	122.2	185.9	297.5	557.8
						100°	8.7	18.2	33.3	48.6	117.7	179.1	286.6	537.3
30° C (6.7)	0° C (1.9)			60°	0.05	5.0	10.5	19.3	28.2	68.3	103.9	166.3	311.7	
						80°	4.8	10.1	18.5	27.0	65.4	99.5	159.3	298.6
						100°	4.7	9.7	17.8	26.0	63.0	95.9	153.5	287.7
		30° C (6.7)	0° C (1.9)	60°	0.21	10.3	21.5	39.3	57.4	139.1	211.6	338.6	634.8	
						80°	9.8	20.6	37.6	55.0	133.2	202.7	324.2	608.0
						100°	9.5	19.8	36.3	53.0	128.3	195.2	312.3	585.6
35° C (7.8)	-40° C (373 mm hg)			60°	0.05	5.4	11.4	20.8	30.5	73.7	112.2	179.5	336.6	
						80°	5.2	10.9	20.0	29.2	70.6	107.5	172.0	322.4
						100°	5.0	10.5	19.2	28.1	68.1	103.6	165.7	310.7
		35° C (7.8)	-20° C (91.4 mm hg)	60°	0.21	11.1	23.2	42.4	62.0	150.1	228.5	365.6	685.4	
						80°	10.6	22.2	40.6	59.4	143.8	218.8	350.1	656.4
						100°	10.2	21.4	39.1	57.2	138.5	210.8	337.2	632.3
35° C (7.8)	-40° C (373 mm hg)			60°	0.05	5.4	11.4	20.8	30.5	73.7	112.2	179.5	336.6	
						80°	5.2	10.9	20.0	29.2	70.6	107.5	172.0	322.4
						100°	5.0	10.5	19.2	28.1	68.1	103.6	165.7	310.7
		35° C (7.8)	-20° C (91.4 mm hg)	60°	0.21	11.1	23.2	42.4	62.0	150.1	228.5	365.6	685.4	
						80°	10.6	22.2	40.6	59.4	143.8	218.8	350.1	656.4
						100°	10.2	21.4	39.1	57.2	138.5	210.8	337.2	632.3
35° C (7.8)	0° C (1.9)			60°	0.05	4.8	10.0	18.3	26.7	64.6	98.3	157.3	294.9	
						80°	4.6	9.5	17.4	25.5	61.7	93.9	150.3	281.7
						100°	4.4	9.2	16.8	24.5	59.3	90.3	144.5	270.9
		35° C (7.8)	0° C (1.9)	60°	0.21	9.7	20.3	37.2	54.4	131.7	200.4	320.7	601.3	
						80°	9.3	19.4	35.5	51.9	125.8	191.4	306.2	574.1
						100°	8.9	18.7	34.2	49.9	120.9	184.0	294.4	552.0
35° C (7.8)	-20° C (91.4 mm hg)			60°	0.05	5.2	10.9	20.0	29.2	70.7	107.6	172.2	322.9	
						80°	5.0	10.4	19.1	27.9	67.6	102.8	164.5	308.4
						100°	4.8	10.0	18.4	26.8	65.0	98.9	158.2	296.6
		35° C (7.8)	-20° C (91.4 mm hg)	60°	0.21	10.7	22.3	40.7	59.6	144.2	219.4	351.0	658.2	
						80°	10.2	21.2	38.9	56.9	137.7	209.5	335.2	628.5
						100°	9.8	20.4	37.4	54.7	132.4	201.4	322.3	604.2
35° C (7.8)	0° C (1.9)			60°	0.05	5.7	11.8	21.7	31.7	76.6	116.6	186.6	349.8	
						80°	5.4	11.3	20.7	30.2	73.2	111.4	178.2	334.2
						100°	5.2	10.9	19.9	29.1	70.4	107.1	171.4	321.3
		35° C (7.8)	0° C (1.9)	60°	0.21	11.5	24.1	44.2	64.5	156.2	237.7	380.4	713.2	
						80°	11.0	23.0	42.2	61.6	149.2	227.0	363.2	681.0
						100°	10.6	22.1	40.5	59.2	143.4	218.2	349.2	654.7

CK4A Hot Gas Discharge Capacities (Tons)

R404A

Cond Temp (Sat Pres) psig	Evap Temp (Sat Pres) psig	Discharge Temp	Pres Drop psi	1/2" 13 mm	3/4" 20 mm	1" 25 mm	1-1/4" 32 mm	2" 50 mm	2-1/2" 65 mm	3" 75 mm	4" 100 mm
75° F (161.2)	-40° F (2.7)	140°	0.75	1.4	3.0	5.4	7.9	19.2	29.3	46.8	87.8
		180°		1.4	2.8	5.2	7.6	18.3	27.8	44.5	83.5
		220°		1.3	2.7	5.0	7.2	17.5	26.7	42.6	80.0
		140°	3	2.8	5.9	10.8	15.8	38.4	58.4	93.4	175.1
		180°		2.7	5.6	10.3	15.1	36.5	55.5	88.8	166.4
		220°		2.6	5.4	9.9	14.4	34.9	53.1	85.0	159.3
75° F (161.2)	0° F (33.5)	140°	0.75	1.6	3.3	6.1	8.9	21.5	32.8	52.5	98.3
		180°		1.5	3.2	5.8	8.5	20.5	31.2	49.9	93.5
		220°		1.4	3.0	5.5	8.1	19.6	29.8	47.7	89.5
		140°	3	3.2	6.6	12.1	17.7	42.9	65.4	104.6	196.1
		180°		3.0	6.3	11.5	16.9	40.8	62.1	99.4	186.3
		220°		2.9	6.0	11.0	16.1	39.1	59.5	95.1	178.4
75° F (161.2)	40° F (86.4)	140°	0.75	1.7	3.7	6.7	9.8	23.7	36.0	57.6	108.0
		180°		1.7	3.5	6.4	9.3	22.5	34.2	54.8	102.7
		220°		1.6	3.3	6.1	8.9	21.5	32.8	52.4	98.3
		140°	3	3.5	7.3	13.3	19.5	47.2	71.8	114.8	215.3
		180°		3.3	6.9	12.7	18.5	44.8	68.2	109.2	204.7
		220°		3.2	6.6	12.1	17.7	42.9	65.3	104.5	195.9
95° F (219.4)	-40° F (2.7)	140°	0.75	1.4	3.0	5.5	8.1	19.6	29.8	47.6	89.3
		180°		1.4	2.8	5.2	7.6	18.4	28.0	44.8	84.1
		220°		1.3	2.7	5.0	7.2	17.5	26.7	42.6	80.0
		140°	3	2.9	6.0	11.0	16.1	39.1	59.4	95.1	178.3
		180°		2.7	5.7	10.4	15.2	36.7	55.9	89.5	167.7
		220°		2.6	5.4	9.9	14.4	34.9	53.2	85.1	159.5
95° F (219.4)	0° F (33.5)	140°	0.75	1.6	3.4	6.3	9.2	22.3	34.0	54.3	101.9
		180°		1.6	3.2	5.9	8.7	21.0	32.0	51.1	95.9
		220°		1.5	3.1	5.6	8.3	20.0	30.4	48.6	91.2
		140°	3	3.3	6.9	12.6	18.4	44.5	67.8	108.5	203.4
		180°		3.1	6.5	11.8	17.3	41.9	63.8	102.0	191.3
		220°		2.9	6.2	11.3	16.5	39.9	60.7	97.0	182.0
95° F (219.4)	40° F (86.4)	140°	0.75	1.8	3.8	7.0	10.3	24.8	37.8	60.5	113.4
		180°		1.7	3.6	6.6	9.7	23.4	35.6	56.9	106.7
		220°		1.6	3.4	6.3	9.2	22.2	33.9	54.2	101.6
		140°	3	3.7	7.7	14.0	20.5	49.6	75.5	120.8	226.4
		180°		3.4	7.2	13.2	19.3	46.7	71.0	113.6	213.0
		220°		3.3	6.8	12.5	18.3	44.4	67.5	108.0	202.6
115° F (290.4)	-40° F (2.7)	140°	0.75	1.4	2.9	5.4	7.9	19.1	29.1	46.5	87.2
		180°		1.3	2.7	5.0	7.3	17.6	26.8	42.9	80.5
		220°		1.2	2.6	4.7	6.9	16.6	25.3	40.4	75.8
		140°	3	2.8	5.9	10.8	15.8	38.2	58.1	92.9	174.2
		180°		2.6	5.4	10.0	14.5	35.2	53.6	85.7	160.8
		220°		2.5	5.1	9.4	13.7	33.2	50.5	80.7	151.4
115° F (290.4)	0° F (33.5)	140°	0.75	1.7	3.5	6.3	9.3	22.4	34.1	54.6	102.4
		180°		1.5	3.2	5.9	8.6	20.7	31.5	50.4	94.5
		220°		1.4	3.0	5.5	8.1	19.5	29.7	47.5	89.0
		140°	3	3.3	6.9	12.7	18.5	44.8	68.2	109.1	204.5
		180°		3.1	6.4	11.7	17.1	41.3	62.9	100.6	188.7
		220°		2.9	6.0	11.0	16.1	38.9	59.2	94.8	177.7
115° F (290.4)	40° F (86.4)	140°	0.75	1.9	3.9	7.2	10.5	25.5	38.8	62.0	116.3
		180°		1.7	3.6	6.6	9.7	23.5	35.8	57.3	107.4
		220°		1.6	3.4	6.3	9.2	22.2	33.7	53.9	101.2
		140°	3	3.8	7.9	14.4	21.0	50.9	77.5	123.9	232.4
		180°		3.5	7.3	13.3	19.4	47.0	71.5	114.4	214.4
		220°		3.3	6.8	12.5	18.3	44.2	67.3	107.7	201.9

CK4A Hot Gas Discharge Capacities (Kilowatts)

R404A

Cond Temp (Sat Pres) bar	Evap Temp (Sat Pres) bar	Discharge Temp	Pres Drop bar	1/2" 13 mm	3/4" 20 mm	1" 25 mm	1-1/4" 32 mm	2" 50 mm	2-1/2" 65 mm	3" 75 mm	4" 100 mm	
25° C (11.2)	-40° C (0.3)	60°	0.05	4.9	10.2	18.7	27.3	66.1	100.5	160.9	301.6	
		80°		4.7	9.7	17.8	26.0	63.1	96.0	153.5	287.9	
		100°		4.5	9.3	17.1	25.0	60.6	92.2	147.5	276.5	
	25° C (11.2)	-20° C (2.0)	60°	0.21	10.0	20.8	38.1	55.7	134.9	205.3	328.5	615.9
			80°		9.5	19.9	36.4	53.2	128.7	195.9	313.4	587.7
			100°		9.1	19.1	34.9	51.1	123.6	188.1	300.9	564.3
25° C (11.2)		0° C (4.9)	60°	0.05	5.4	11.3	20.7	30.3	73.4	111.6	178.6	334.9
			80°		5.2	10.8	19.8	28.9	70.0	106.6	170.5	319.7
			100°		5.0	10.4	19.0	27.8	67.3	102.3	163.7	307.0
	25° C (11.2)	0° C (4.9)	60°	0.21	11.1	23.1	42.3	61.9	149.8	228.0	364.8	683.9
			80°		10.6	22.1	40.4	59.0	143.0	217.5	348.1	652.6
			100°		10.1	21.2	38.8	56.7	137.3	208.9	334.2	626.6
30° C (13.1)		-40° C (0.3)	60°	0.05	5.9	12.4	22.7	33.1	80.2	122.0	195.2	366.0
			80°		5.7	11.8	21.6	31.6	76.5	116.5	186.3	349.4
			100°		5.4	11.3	20.8	30.4	73.5	111.8	178.9	335.5
	30° C (13.1)	-20° C (2.0)	60°	0.21	12.1	25.3	46.3	67.6	163.7	249.1	398.6	747.4
			80°		11.5	24.1	44.2	64.5	156.2	237.7	380.4	713.2
			100°		11.1	23.2	42.4	62.0	150.0	228.3	365.2	684.8
30° C (13.1)		-40° C (0.3)	60°	0.05	4.9	10.3	18.8	27.5	66.6	101.4	162.2	304.2
			80°		4.7	9.8	17.9	26.2	63.4	96.4	154.3	289.3
			100°		4.5	9.4	17.2	25.1	60.7	92.4	147.8	277.1
	30° C (13.1)	-20° C (2.0)	60°	0.21	10.1	21.0	38.5	56.2	136.1	207.2	331.5	621.5
			80°		9.6	20.0	36.6	53.5	129.4	197.0	315.1	590.9
			100°		9.2	19.1	35.0	51.2	124.0	188.6	301.8	565.9
30° C (13.1)		0° C (4.9)	60°	0.05	5.5	11.5	21.1	30.8	74.5	113.4	181.5	340.2
			80°		5.2	10.9	20.0	29.3	70.9	107.9	172.6	323.6
			100°		5.0	10.5	19.2	28.0	67.9	103.3	165.3	310.0
	30° C (13.1)	0° C (4.9)	60°	0.21	11.3	23.5	43.0	62.9	152.3	231.7	370.8	695.2
			80°		10.7	22.3	40.9	59.8	144.8	220.3	352.5	660.9
			100°		10.2	21.4	39.2	57.3	138.7	211.0	337.6	633.0
35° C (15.1)		-40° C (0.3)	60°	0.05	6.1	12.6	23.1	33.8	81.9	124.6	199.4	373.9
			80°		5.8	12.0	22.0	32.2	77.9	118.5	189.6	355.5
			100°		5.5	11.5	21.1	30.8	74.6	113.5	181.7	340.6
	35° C (15.1)	-20° C (2.0)	60°	0.21	12.4	25.8	47.3	69.1	167.3	254.7	407.5	764.0
			80°		11.8	24.6	45.0	65.7	159.1	242.1	387.3	726.3
			100°		11.3	23.5	43.1	62.9	152.4	231.9	371.0	695.6
35° C (15.1)		-40° C (0.3)	60°	0.05	6.2	12.9	23.6	34.4	83.3	126.8	202.9	380.4
			80°		5.8	12.2	22.3	32.6	78.9	120.0	192.0	360.0
			100°		5.6	11.6	21.3	31.1	75.3	114.6	183.4	343.8
	35° C (15.1)	-20° C (2.0)	60°	0.21	12.6	26.3	48.2	70.4	170.5	259.4	415.0	778.2
			80°		11.9	24.9	45.6	66.6	161.2	245.4	392.6	736.1
			100°		11.4	23.8	43.5	63.6	153.9	234.3	374.8	702.8



CK4A Hot Gas Discharge Capacities (Tons)

R507

Cond Temp (Sat Pres) psig	Evap Temp (Sat Pres) psig	Discharge Temp	Pres Drop psi	1/2" 13 mm	3/4" 20 mm	1" 25 mm	1-1/4" 32 mm	2" 50 mm	2-1/2" 65 mm	3" 75 mm	4" 100 mm
75° F (167)	-40° F (5.5)	140°	0.75	1.4	3.0	5.5	8.0	19.4	29.6	47.3	88.8
		180°		1.4	2.9	5.2	7.6	18.5	28.1	45.0	84.4
		220°		1.3	2.7	5.0	7.3	17.7	27.0	43.1	80.9
		140°	3	2.9	6.0	11.0	16.0	38.8	59.0	94.4	176.9
		180°		2.7	5.7	10.4	15.2	36.8	56.1	89.7	168.2
		220°		2.6	5.4	10.0	14.6	35.3	53.7	86.0	161.2
75° F (167)	0° F (35.2)	140°	0.75	1.6	3.3	6.1	8.9	21.6	32.9	52.7	98.8
		180°		1.5	3.2	5.8	8.5	20.6	31.3	50.1	93.9
		220°		1.5	3.0	5.6	8.1	19.7	30.0	48.0	90.0
		140°	3	3.2	6.7	12.2	17.8	43.1	65.6	105.0	196.9
		180°		3.0	6.3	11.6	16.9	41.0	62.4	99.8	187.2
		220°		2.9	6.1	11.1	16.2	39.3	59.8	95.6	179.3
75° F (167)	40° F (87.8)	140°	0.75	1.8	3.7	6.7	9.8	23.7	36.1	57.7	108.2
		180°		1.7	3.5	6.4	9.3	22.5	34.3	54.9	102.9
		220°		1.6	3.3	6.1	8.9	21.6	32.9	52.6	98.6
		140°	3	3.5	7.3	13.4	19.5	47.2	71.9	115.0	215.7
		180°		3.3	6.9	12.7	18.6	44.9	68.3	109.4	205.0
		220°		3.2	6.6	12.2	17.8	43.0	65.5	104.8	196.4
95° F (226)	-40° F (5.5)	140°	0.75	1.5	3.1	5.7	8.3	20.1	30.6	48.9	91.7
		180°		1.4	2.9	5.3	7.8	18.9	28.8	46.1	86.4
		220°		1.3	2.8	5.1	7.4	18.0	27.4	43.9	82.3
		140°	3	3.0	6.2	11.3	16.6	40.1	61.0	97.6	183.0
		180°		2.8	5.8	10.7	15.6	37.7	57.4	91.9	172.3
		220°		2.7	5.5	10.2	14.9	36.0	54.7	87.5	164.1
95° F (226)	0° F (35.2)	140°	0.75	1.7	3.5	6.4	9.4	22.7	34.6	55.3	103.7
		180°		1.6	3.3	6.0	8.8	21.4	32.5	52.1	97.6
		220°		1.5	3.1	5.8	8.4	20.4	31.0	49.6	93.0
		140°	3	3.3	7.0	12.8	18.7	45.3	68.9	110.3	206.8
		180°		3.2	6.6	12.1	17.6	42.7	64.9	103.9	194.7
		220°		3.0	6.3	11.5	16.8	40.6	61.8	98.9	185.5
95° F (226)	40° F (87.8)	140°	0.75	1.9	3.9	7.1	10.4	25.2	38.3	61.3	114.9
		180°		1.8	3.7	6.7	9.8	23.7	36.1	57.7	108.2
		220°		1.7	3.5	6.4	9.3	22.6	34.4	55.0	103.1
		140°	3	3.7	7.8	14.2	20.7	50.2	76.4	122.3	229.2
		180°		3.5	7.3	13.4	19.5	47.3	72.0	115.1	215.9
		220°		3.3	7.0	12.7	18.6	45.0	68.5	109.7	205.6
115° F (301)	-40° F (5.5)	140°	0.75	1.5	3.1	5.7	8.3	20.2	30.7	49.1	92.1
		180°		1.4	2.9	5.3	7.7	18.7	28.4	45.5	85.3
		220°		1.3	2.7	5.0	7.3	17.6	26.8	42.9	80.5
		140°	3	3.0	6.2	11.4	16.7	40.3	61.4	98.2	184.1
		180°		2.8	5.8	10.5	15.4	37.3	56.8	90.9	170.3
		220°		2.6	5.4	10.0	14.5	35.2	53.6	85.7	160.7
115° F (301)	0° F (35.2)	140°	0.75	1.7	3.6	6.6	9.6	23.3	35.5	56.8	106.5
		180°		1.6	3.3	6.1	8.9	21.6	32.9	52.6	98.6
		220°		1.5	3.1	5.8	8.4	20.4	31.0	49.6	93.1
		140°	3	3.4	7.2	13.2	19.3	46.6	71.0	113.5	212.9
		180°		3.2	6.7	12.2	17.8	43.1	65.6	105.0	196.9
		220°		3.0	6.3	11.5	16.8	40.7	61.9	99.1	185.8
115° F (301)	40° F (89.8)	140°	0.75	1.9	4.1	7.4	10.9	26.3	40.0	64.0	120.1
		180°		1.8	3.8	6.9	10.1	24.3	37.0	59.3	111.1
		220°		1.7	3.5	6.5	9.5	23.0	35.0	55.9	104.9
		140°	3	3.9	8.1	14.9	21.7	52.6	80.0	128.0	240.0
		180°		3.6	7.5	13.7	20.1	48.6	74.0	118.4	222.0
		220°		3.4	7.1	13.0	19.0	45.9	69.8	111.7	209.4



CK4A Hot Gas Discharge Capacities (Kilowatts)

R507

Cond Temp (Sat Pres) bar	Evap Temp (Sat Pres) bar	Discharge Temp	Pres Drop bar	1/2" 13 mm	3/4" 20 mm	1" 25 mm	1-1/4" 32 mm	2" 50 mm	2-1/2" 65 mm	3" 75 mm	4" 100 mm	
25° C (11.6)	-40° C (0.4)	60°	0.05	4.9	10.3	18.9	27.6	66.8	101.7	162.8	305.2	
		80°		4.7	9.9	18.0	26.4	63.8	97.1	155.4	291.4	
		100°		4.5	9.5	17.3	25.3	61.3	93.3	149.4	280.0	
	25° C (11.6)	-20° C (2.1)	60°	0.21	10.1	21.1	38.6	56.4	136.5	207.8	332.4	623.3
			80°		9.6	20.1	36.8	53.8	130.3	198.3	317.3	595.0
			100°		9.3	19.3	35.4	51.7	125.2	190.6	304.9	571.7
25° C (11.6)		0° C (5.2)	60°	0.05	5.5	11.4	20.8	30.5	73.8	112.3	179.6	336.8
			80°		5.2	10.9	19.9	29.1	70.4	107.2	171.5	321.6
			100°		5.0	10.4	19.1	28.0	67.7	103.0	164.8	309.1
	25° C (11.6)	0° C (5.2)	60°	0.21	11.1	23.3	42.6	62.2	150.7	229.3	366.9	687.9
			80°		10.6	22.2	40.6	59.4	143.8	218.9	350.2	656.6
			100°		10.2	21.3	39.1	57.1	138.2	210.3	336.5	631.0
30° C (13.5)		-40° C (0.4)	60°	0.05	5.0	10.5	19.2	28.1	67.9	103.3	165.4	310.0
			80°		4.8	10.0	18.3	26.7	64.6	98.3	157.3	295.0
			100°		4.6	9.6	17.5	25.6	62.0	94.3	150.8	282.8
	30° C (13.5)	-20° C (2.1)	60°	0.21	10.3	21.4	39.2	57.3	138.8	211.2	337.9	633.6
			80°		9.8	20.4	37.3	54.5	132.0	200.9	321.4	602.6
			100°		9.4	19.5	35.8	52.3	126.5	192.6	308.1	577.7
30° C (13.5)		0° C (5.2)	60°	0.05	5.6	11.6	21.3	31.1	75.4	114.8	183.6	344.3
			80°		5.3	11.1	20.3	29.6	71.7	109.2	174.7	327.5
			100°		5.1	10.6	19.4	28.4	68.8	104.7	167.5	314.0
	30° C (13.5)	0° C (5.2)	60°	0.21	11.4	23.8	43.6	63.7	154.1	234.5	375.2	703.6
			80°		10.8	22.6	41.4	60.5	146.6	223.1	356.9	669.2
			100°		10.4	21.7	39.7	58.0	140.5	213.8	342.1	641.5
35° C (15.6)		-40° C (0.4)	60°	0.05	6.1	12.7	23.3	34.1	82.5	125.6	201.0	376.8
			80°		5.8	12.1	22.2	32.4	78.5	119.5	191.2	358.5
			100°		5.6	11.6	21.3	31.1	75.3	114.6	183.3	343.7
	35° C (15.6)	-20° C (2.1)	60°	0.21	12.5	26.0	47.7	69.7	168.7	256.7	410.7	770.0
			80°		11.9	24.8	45.3	66.3	160.4	244.1	390.6	732.4
			100°		11.4	23.7	43.5	63.5	153.8	234.0	374.5	702.1
35° C (15.6)		0° C (5.2)	60°	0.05	5.1	10.6	19.4	28.4	68.7	104.5	167.2	313.4
			80°		4.8	10.0	18.4	26.9	65.0	98.9	158.3	296.8
			100°		4.6	9.6	17.6	25.7	62.2	94.6	151.4	283.8
	35° C (15.6)	-20° C (2.1)	60°	0.21	10.4	21.7	39.7	58.0	140.3	213.6	341.7	640.7
			80°		9.8	20.5	37.6	54.9	132.9	202.2	323.5	606.6
			100°		9.4	19.6	35.9	52.5	127.0	193.3	309.3	579.9
35° C (15.6)		0° C (5.2)	60°	0.05	5.7	11.9	21.7	31.7	76.8	116.8	186.9	350.5
			80°		5.4	11.2	20.5	30.0	72.7	110.6	177.0	331.9
			100°		5.1	10.7	19.6	28.7	69.5	105.8	169.3	317.4
	35° C (15.6)	0° C (5.2)	60°	0.21	11.6	24.2	44.4	64.8	156.9	238.8	382.1	716.5
			80°		11.0	22.9	42.0	61.4	148.6	226.1	361.8	678.3
			100°		10.5	21.9	40.1	58.7	142.0	216.1	345.8	648.4
35° C (15.6)		0° C (5.2)	60°	0.05	6.2	13.0	23.9	34.9	84.5	128.6	205.7	385.7
			80°		5.9	12.4	22.6	33.1	80.0	121.8	194.8	365.3
			100°		5.7	11.8	21.6	31.6	76.5	116.4	186.3	349.3
	35° C (15.6)	0° C (5.2)	60°	0.21	12.8	26.7	48.8	71.3	172.7	262.8	420.5	788.5
			80°		12.1	25.2	46.2	67.5	163.5	248.8	398.2	746.5
			100°		11.6	24.1	44.2	64.6	156.3	237.9	380.6	713.6



A9, A8_0 Condenser Bypass Capacities (Tons)

R22

Cond Temp (Sat pres) psig	Ev. Temp (Sat Pres) psig	Discharge Temp	Pres Drop psi	A9	A9	A9	A9	A8AOE	A8AOE	A8AOE	A81OE	A81OE	A82OE	A82OE		
				3/8" 9 mm	5/8" 15 mm	7/8" 22 mm	1-1/8" 28 mm	3/8" 9 mm	5/8" 15 mm	7/8" 22 mm	1-1/8" 28 mm	1-3/8" 35 mm	1-5/8" 42 mm	2-1/8" 54 mm		
75° F (132)	-40° F (5.5)	140°	10	3.5	9.9	28.1	39.8	14.4	36.9	52.4	66.9	117.8	176.0	308.9		
				180°	3.6	10.1	28.7	40.6	14.8	38.0	54.0	68.9	121.4	181.4	318.4	
				220°	3.7	10.3	29.3	41.5	15.1	38.9	55.2	70.4	124.1	185.5	325.5	
		15	140°	4.3	12.3	35.0	49.9	17.9	46.2	65.8	84.1	147.6	221.1	387.3		
			180°	4.4	12.5	35.7	50.9	18.4	47.6	67.8	86.7	152.2	227.9	399.2		
			220°	4.5	12.8	36.5	52.0	18.8	48.7	69.3	88.7	155.6	233.0	408.1		
	0° F (35.2)	140°	10	3.7	10.5	29.8	42.2	15.3	39.2	55.6	70.9	124.9	186.8	327.7		
				180°	3.8	10.7	30.4	43.1	15.7	40.4	57.3	73.1	128.7	192.5	337.8	
				220°	3.9	10.9	31.1	44.0	16.1	41.3	58.5	74.7	131.6	196.8	345.3	
		15	140°	4.6	13.0	37.1	53.0	18.9	49.0	69.8	89.2	156.5	234.4	410.6		
			180°	4.7	13.3	37.8	54.0	19.5	50.5	71.9	91.9	161.3	241.6	423.2		
			220°	4.8	13.6	38.7	55.2	20.0	51.6	73.5	94.0	164.9	247.0	432.6		
75° F (132)	40° F (87.8)	140°	10	3.9	11.0	31.4	44.4	16.0	41.1	58.4	74.5	131.3	196.3	344.4		
				180°	4.0	11.2	32.0	45.3	16.5	42.4	60.2	76.8	135.3	202.3	355.0	
				220°	4.1	11.5	32.7	46.2	16.9	43.4	61.5	78.5	138.3	206.8	362.9	
		15	140°	4.8	13.7	39.0	55.6	19.9	51.4	73.3	93.7	164.4	246.3	431.3		
			180°	4.9	13.9	39.8	56.7	20.5	53.0	75.6	96.6	169.5	253.8	444.6		
			220°	5.0	14.2	40.6	58.0	21.0	54.2	77.2	98.7	173.3	259.5	454.5		
	95° F (182)	-40° F (5.5)	140°	10	2.9	8.1	23.0	32.4	11.7	30.0	42.5	54.3	95.8	143.0	251.2	
					180°	2.9	8.2	23.4	32.9	12.1	30.9	43.7	55.8	98.5	147.1	258.3
					220°	3.0	8.4	23.9	33.6	12.3	31.5	44.7	57.0	100.6	150.2	263.8
			15	140°	3.5	9.9	28.4	40.2	14.5	37.3	53.0	67.6	119.0	178.0	312.1	
				180°	3.6	10.1	28.9	41.0	14.9	38.3	54.4	69.5	122.4	183.0	321.0	
				220°	3.7	10.3	29.5	41.8	15.2	39.2	55.6	71.0	125.0	186.9	327.9	
0° F (35.2)		140°	10	3.1	8.6	24.5	34.5	12.5	32.0	45.4	57.9	102.2	152.6	268.0		
				180°	3.1	8.8	24.9	35.1	12.9	32.9	46.7	59.5	105.0	156.9	275.5	
				220°	3.2	8.9	25.5	35.9	13.2	33.7	47.7	60.8	107.3	160.2	281.5	
		15	140°	3.8	10.6	30.2	42.9	15.4	39.7	56.5	72.1	126.9	189.7	332.8		
			180°	3.8	10.8	30.8	43.7	15.9	40.9	58.1	74.1	130.4	195.1	342.2		
			220°	3.9	11.0	31.4	44.6	16.2	41.7	59.3	75.7	133.3	199.3	349.6		
95° F (182)	40° F (87.8)	140°	10	3.2	9.1	25.9	36.4	13.2	33.8	47.9	61.1	107.8	161.1	282.9		
				180°	3.3	9.2	26.3	37.1	13.6	34.8	49.3	62.8	110.9	165.6	290.9	
				220°	3.4	9.4	26.9	37.9	13.9	35.5	50.3	64.2	113.2	169.1	297.1	
		15	140°	4.0	11.2	31.9	45.3	16.3	41.9	59.6	76.1	133.8	200.2	351.1		
			180°	4.1	11.4	32.5	46.1	16.8	43.1	61.3	78.2	137.6	205.9	361.1		
			220°	4.1	11.6	33.2	47.0	17.1	44.0	62.6	79.9	140.6	210.3	368.8		
	115° F (243)	-40° F (5.5)	140°	10	2.4	6.8	19.3	27.1	9.9	25.2	35.7	45.5	80.3	119.9	210.7	
					180°	2.5	6.9	19.6	27.5	10.1	25.8	36.5	46.5	82.2	122.7	215.7
					220°	2.5	7.0	20.0	28.1	10.3	26.3	37.2	47.5	83.9	125.2	220.0
			15	140°	3.0	8.4	23.8	33.6	12.2	31.2	44.2	56.4	99.4	148.5	260.8	
				180°	3.0	8.5	24.1	34.1	12.5	31.9	45.2	57.7	101.8	152.1	267.0	
				220°	3.1	8.6	24.6	34.7	12.7	32.6	46.2	58.9	103.8	155.1	272.4	
0° F (35.2)		140°	10	2.6	7.3	20.7	29.2	10.6	27.1	38.3	48.8	86.3	128.8	226.3		
				180°	2.6	7.4	21.0	29.6	10.9	27.7	39.2	50.0	88.3	131.8	231.7	
				220°	2.7	7.5	21.4	30.1	11.1	28.3	40.0	51.0	90.1	134.5	236.3	
		15	140°	3.2	9.0	25.5	36.1	13.1	33.5	47.4	60.5	106.7	159.5	279.9		
			180°	3.2	9.1	25.9	36.6	13.4	34.3	48.6	62.0	109.3	163.3	286.6		
			220°	3.3	9.3	26.4	37.3	13.6	35.0	49.5	63.2	111.5	166.6	292.4		
115° F (243)	40° F (87.8)	140°	10	2.8	7.7	22.0	30.9	11.3	28.7	40.6	51.8	91.6	136.7	240.2		
				180°	2.8	7.8	22.3	31.4	11.5	29.4	41.6	53.0	93.7	139.9	245.9	
				220°	2.9	8.0	22.8	32.0	11.8	30.0	42.4	54.1	95.6	142.7	250.8	
		15	140°	3.4	9.5	27.1	38.3	13.8	35.5	50.3	64.2	113.2	169.2	297.0		
			180°	3.4	9.7	27.5	38.8	14.2	36.3	51.5	65.7	115.9	173.2	304.1		
			220°	3.5	9.8	28.0	39.6	14.5	37.1	52.6	67.1	118.2	176.7	310.2		



A9, A8_0 Condenser Bypass Capacities (Kilowatts)

R22

Cond Temp (Sat Pres) bar	Ev. Temp (Sat Pres) bar	Discharge Temp	Pres Drop bar	A9 3/8" 9 mm	A9 5/8" 15 mm	A9 7/8" 22 mm	A9 1-1/8" 28 mm	A8AOE 3/8" 9 mm	A8AOE 5/8" 15 mm	A8AOE 7/8" 22 mm	A81OE 1-1/8" 28 mm	A81OE 1-3/8" 35 mm	A82OE 1-5/8" 42 mm	A82OE 2-1/8" 54 mm		
25° C (9.2)	-40° C (0.4)	60°	0.7	12.9	36.1	103.0	145.7	52.6	135.1	191.7	244.7	431.1	644.4	1130.8		
				80°	13.1	36.8	104.9	148.4	53.6	137.6	195.2	249.2	438.9	656.2	1151.5	
				100°	13.4	37.5	107.0	151.3	54.7	140.3	199.1	254.1	447.6	669.1	1174.3	
		60°	1	15.5	43.8	124.9	178.0	63.8	164.7	234.5	299.8	526.4	788.0	1380.7		
				80°	15.8	44.6	127.2	181.3	65.0	167.7	238.9	305.3	536.0	802.5	1406.1	
				100°	16.1	45.5	129.8	184.9	66.2	171.1	243.6	311.3	546.7	818.4	1434.0	
	25° C (9.2)	-20° C (2.1)	60°	0.7	13.6	38.1	108.7	153.8	55.6	142.6	202.3	258.3	455.0	680.1	1193.5	
					80°	13.8	38.8	110.7	156.6	56.6	145.2	206.0	263.0	463.3	692.5	1215.4
					100°	14.1	39.6	112.9	159.7	57.7	148.1	210.1	268.2	472.4	706.2	1239.4
			60°	1	16.4	46.2	131.8	187.8	67.3	173.8	247.4	316.2	555.3	831.3	1456.6	
					80°	16.7	47.1	134.2	191.3	68.5	177.0	252.0	322.0	565.5	846.6	1483.4
					100°	17.0	48.0	136.9	195.1	69.9	180.5	257.0	328.4	576.7	863.4	1512.8
25° C (9.2)	0° C (5.2)	60°	0.7	14.2	40.0	113.9	161.1	58.2	149.4	211.9	270.5	476.5	712.3	1250.1		
				80°	14.5	40.7	116.0	164.0	59.3	152.1	215.8	275.5	485.2	725.4	1273.0	
				100°	14.8	41.5	118.3	167.3	60.4	155.1	220.1	280.9	494.8	739.7	1298.2	
		60°	1	17.2	48.4	138.0	196.7	70.4	181.9	259.1	331.1	581.4	870.4	1525.1		
				80°	17.5	49.3	140.6	200.3	71.7	185.3	263.8	337.2	592.1	886.4	1553.1	
				100°	17.8	50.2	143.3	204.2	73.2	189.0	269.1	343.9	603.8	904.0	1583.9	
30° C (10.9)	-40° C (0.4)	60°	0.7	11.6	32.6	92.9	131.1	47.5	121.6	172.4	220.0	387.9	579.7	1017.7		
				80°	11.8	33.2	94.5	133.4	48.3	123.8	175.5	223.9	394.8	589.9	1035.7	
				100°	12.1	33.8	96.4	136.0	49.2	126.2	178.9	228.2	402.4	601.3	1055.8	
		60°	1	14.0	39.4	112.2	159.4	57.3	147.6	209.9	268.2	471.5	705.4	1236.8		
				80°	14.2	40.1	114.2	162.3	58.3	150.3	213.6	272.9	479.9	717.9	1258.8	
				100°	14.5	40.8	116.5	165.4	59.5	153.2	217.8	278.2	489.2	731.9	1283.2	
	30° C (10.9)	-20° C (2.1)	60°	0.7	12.3	34.5	98.2	138.7	50.2	128.7	182.4	232.7	410.3	613.1	1076.5	
					80°	12.5	35.1	100.0	141.2	51.1	130.9	185.6	236.8	417.6	623.9	1095.5
					100°	12.8	35.8	101.9	143.9	52.1	133.5	189.2	241.4	425.7	636.1	1116.7
			60°	1	14.8	41.6	118.7	168.6	60.6	156.1	222.0	283.5	498.5	745.9	1307.7	
					80°	15.1	42.3	120.8	171.6	61.7	158.9	225.9	288.5	507.3	759.1	1330.9
					100°	15.3	43.2	123.1	174.9	62.9	162.0	230.3	294.1	517.2	773.8	1356.8
30° C (10.9)	0° C (5.2)	60°	0.7	12.9	36.2	103.1	145.5	52.7	135.0	191.4	244.2	430.5	643.3	1129.5		
				80°	13.1	36.8	104.9	148.1	53.6	137.4	194.8	248.5	438.1	654.7	1149.5	
				100°	13.4	37.5	107.0	151.0	54.7	140.1	198.5	253.3	446.6	667.4	1171.8	
		60°	1	15.5	43.6	124.5	176.8	63.6	163.7	232.8	297.4	522.9	782.3	1371.6		
				80°	15.8	44.4	126.7	180.0	64.7	166.6	236.9	302.6	532.2	796.2	1395.9	
				100°	16.1	45.3	129.1	183.5	66.0	169.9	241.5	308.5	542.5	811.7	1423.1	
35° C (12.6)	-40° C (0.4)	60°	0.7	10.6	29.7	84.6	119.3	43.3	110.7	156.8	200.0	352.9	527.2	925.9		
				80°	10.8	30.2	86.1	121.3	44.0	112.6	159.4	203.4	358.9	536.0	941.5	
				100°	11.0	30.8	87.7	123.6	44.8	114.7	162.5	207.2	365.6	546.2	959.3	
		60°	1	12.7	35.8	102.0	144.6	52.1	134.0	190.3	243.0	427.6	639.5	1121.8		
				80°	13.0	36.4	103.8	147.0	53.0	136.2	193.5	247.1	434.9	650.3	1140.8	
				100°	13.2	37.1	105.7	149.8	54.0	138.8	197.2	251.7	443.1	662.6	1162.4	
	35° C (12.6)	-20° C (2.1)	60°	0.7	11.2	31.5	89.7	126.5	45.9	117.4	166.3	212.1	374.2	559.0	981.8	
					80°	11.4	32.0	91.3	128.6	46.6	119.4	169.1	215.7	380.5	568.4	998.3
					100°	11.7	32.6	93.0	131.0	47.5	121.6	172.3	219.7	387.7	579.1	1017.1
			60°	1	13.5	37.9	108.1	153.2	55.2	142.0	201.7	257.5	453.2	677.8	1188.9	
					80°	13.7	38.6	110.0	155.8	56.2	144.4	205.1	261.8	460.9	689.2	1209.0
					100°	14.0	39.3	112.1	158.8	57.2	147.1	209.0	266.8	469.6	702.3	1232.0
35° C (12.6)	0° C (5.2)	60°	0.7	11.8	33.1	94.3	133.0	48.2	123.4	174.8	223.0	393.4	587.7	1032.2		
				80°	12.0	33.7	95.9	135.2	49.0	125.5	177.7	226.7	400.0	597.5	1049.5	
				100°	12.2	34.3	97.8	137.8	50.0	127.9	181.1	231.0	407.6	608.8	1069.3	
		60°	1	14.2	39.9	113.6	161.1	58.0	149.2	211.9	270.6	476.3	712.3	1249.5		
				80°	14.4	40.5	115.6	163.8	59.0	151.8	215.5	275.2	484.4	724.3	1270.6	
				100°	14.7	41.3	117.8	166.9	60.2	154.6	219.6	280.4	493.5	738.0	1294.7	



A9, A8_0 Condenser Bypass Capacities - Tons R134a Refrigeration & Air Conditioning Control Valves

A9, A8_0 Condenser Bypass Capacities (Tons)													R134a			
Cond Temp (Sat pres) psig	Ev. Temp (Sat Pres) psig	Discharge Temp	Pres Drop psi	A9 3/8" 9 mm	A9 5/8" 15 mm	A9 7/8" 22 mm	A9 1-1/8" 28 mm	A8AOE 3/8" 9 mm	A8AOE 5/8" 15 mm	A8AOE 7/8" 22 mm	A81OE 1-1/8" 28 mm	A81OE 1-3/8" 35 mm	A82OE 1-5/8" 42 mm	A82OE 2-1/8" 54 mm		
75° F (78.6)	-40° F (5.5)	140°	10	2.4	6.9	19.6	28.0	10.0	25.9	36.9	47.2	82.8	124.0	217.1		
				180°	2.5	7.1	20.3	29.1	10.6	27.4	39.0	49.9	87.5	131.1	229.5	
				220°	2.6	7.4	21.1	30.2	11.0	28.4	40.5	51.8	90.8	136.1	238.3	
		140°	15	3.0	8.6	24.5	35.6	12.5	32.7	47.0	60.3	105.1	157.9	275.5		
				180°	3.1	8.9	25.4	36.9	13.2	34.6	49.7	63.8	111.1	166.9	291.2	
				220°	3.2	9.2	26.4	38.3	13.7	35.9	51.6	66.2	115.3	173.2	302.3	
	75° F (78.6)	0° F (35.2)	140°	10	2.7	7.5	21.4	30.7	10.9	28.3	40.4	51.7	90.7	135.8	237.8	
					180°	2.8	7.8	22.2	31.8	11.6	30.0	42.7	54.7	95.8	143.6	251.4
					220°	2.9	8.1	23.1	33.0	12.0	31.1	44.4	56.8	99.5	149.1	260.9
140°			15	3.3	9.4	26.8	38.9	13.6	35.8	51.4	66.0	114.9	172.6	301.2		
				180°	3.4	9.7	27.8	40.4	14.4	37.8	54.4	69.7	121.4	182.5	318.4	
				220°	3.5	10.1	28.8	41.9	15.0	39.3	56.4	72.4	126.0	189.4	330.5	
75° F (78.6)	40° F (87.8)	140°	10	2.9	8.1	23.2	33.2	11.9	30.7	43.8	56.0	98.2	147.2	257.7		
				180°	3.0	8.4	24.1	34.5	12.5	32.5	46.3	59.2	103.8	155.6	272.4	
				220°	3.1	8.8	25.0	35.8	13.0	33.7	48.1	61.5	107.8	161.5	282.7	
		140°	15	3.6	10.1	29.0	42.1	14.7	38.7	55.7	71.4	124.3	186.8	325.9		
				180°	3.7	10.5	30.1	43.7	15.6	40.9	58.8	75.5	131.4	197.5	344.5	
				220°	3.8	10.9	31.2	45.3	16.2	42.5	61.1	78.3	136.4	205.0	357.6	
	95° F (113.8)	-40° F (5.5)	140°	10	2.0	5.5	15.8	22.4	8.0	20.7	29.5	37.6	66.2	99.0	173.6	
					180°	2.0	5.7	16.3	23.2	8.5	21.9	31.1	39.7	69.8	104.4	183.1
					220°	2.1	5.9	16.9	24.0	8.8	22.7	32.2	41.2	72.4	108.3	189.9
140°			15	2.4	6.8	19.5	28.0	10.0	25.9	36.9	47.3	82.8	124.1	217.1		
				180°	2.5	7.1	20.2	29.0	10.5	27.3	39.0	49.9	87.3	130.9	229.0	
				220°	2.6	7.3	21.0	30.1	10.9	28.3	40.4	51.7	90.6	135.8	237.5	
95° F (113.8)		0° F (35.2)	140°	10	2.2	6.1	17.5	24.8	8.9	22.9	32.6	41.7	73.3	109.6	192.2	
					180°	2.3	6.3	18.1	25.7	9.4	24.2	34.4	43.9	77.3	115.6	202.7
					220°	2.3	6.6	18.7	26.6	9.8	25.1	35.7	45.6	80.2	119.9	210.3
	140°		15	2.7	7.6	21.6	31.0	11.0	28.6	40.8	52.3	91.5	137.2	240.0		
				180°	2.8	7.8	22.4	32.1	11.6	30.2	43.1	55.1	96.5	144.7	253.2	
				220°	2.9	8.1	23.2	33.3	12.0	31.3	44.7	57.2	100.1	150.1	262.6	
95° F (113.8)	40° F (87.8)	140°	10	2.4	6.7	19.1	27.1	9.7	25.1	35.7	45.5	80.1	119.8	210.1		
				180°	2.5	6.9	19.8	28.1	10.3	26.5	37.6	48.0	84.5	126.4	221.6	
				220°	2.6	7.2	20.5	29.1	10.7	27.4	39.0	49.8	87.6	131.1	229.9	
		140°	15	2.9	8.3	23.6	33.8	12.0	31.2	44.6	57.1	99.9	149.8	262.0		
				180°	3.0	8.5	24.4	35.0	12.7	32.9	47.1	60.2	105.4	158.0	276.4	
				220°	3.1	8.9	25.3	36.3	13.2	34.2	48.8	62.4	109.3	163.9	286.7	
	115° F (158.4)	-40° F (5.5)	140°	10	1.6	4.6	13.0	18.4	6.6	17.0	24.2	30.8	54.3	81.2	142.6	
					180°	1.7	4.7	13.4	19.0	7.0	17.9	25.4	32.4	57.1	85.3	149.8
					220°	1.7	4.9	13.9	19.6	7.2	18.5	26.3	33.5	59.1	88.4	155.1
140°			15	2.0	5.6	16.1	22.9	8.2	21.2	30.1	38.5	67.6	101.2	177.4		
				180°	2.1	5.8	16.6	23.6	8.6	22.2	31.7	40.4	71.1	106.4	186.4	
				220°	2.1	6.0	17.2	24.5	8.9	23.0	32.8	41.9	73.6	110.2	193.1	
115° F (158.4)		0° F (35.2)	140°	10	1.8	5.1	14.6	20.6	7.5	19.1	27.1	34.6	61.1	91.2	160.2	
					180°	1.9	5.3	15.1	21.3	7.8	20.1	28.5	36.4	64.1	95.8	168.3
					220°	2.0	5.5	15.6	22.1	8.1	20.8	29.5	37.7	66.4	99.3	174.3
	140°		15	2.2	6.3	18.0	25.7	9.2	23.7	33.8	43.2	75.9	113.5	199.0		
				180°	2.3	6.5	18.6	26.5	9.7	24.9	35.5	45.4	79.7	119.3	209.1	
				220°	2.4	6.8	19.3	27.4	10.0	25.8	36.8	47.0	82.6	123.6	216.6	
115° F (158.4)	40° F (87.8)	140°	10	2.0	5.7	16.2	22.8	8.3	21.2	30.0	38.3	67.5	100.9	177.1		
				180°	2.1	5.9	16.7	23.6	8.7	22.2	31.5	40.2	70.9	106.0	186.1	
				220°	2.2	6.1	17.3	24.4	9.0	23.0	32.7	41.7	73.5	109.8	192.7	
		140°	15	2.5	7.0	19.9	28.3	10.2	26.2	37.3	47.7	83.8	125.4	219.7		
				180°	2.6	7.2	20.6	29.3	10.7	27.6	39.2	50.1	88.0	131.7	230.9	
				220°	2.7	7.5	21.3	30.3	11.1	28.5	40.6	51.9	91.2	136.5	239.2	



A9, A8 0 Condenser Bypass Capacities (Kilowatts) R134a

Cond Temp (Sat Pres) bar	Ev. Temp (Sat Pres) bar	Discharge Temp	Pres Drop bar	A9 3/8" 9 mm	A9 5/8" 15 mm	A9 7/8" 22 mm	A9 1-1/8" 28 mm	A8AOE 3/8" 9 mm	A8AOE 5/8" 15 mm	A8AOE 7/8" 22 mm	A81OE 1-1/8" 28 mm	A81OE 1-3/8" 35 mm	A82OE 1-5/8" 42 mm	A82OE 2-1/8" 54 mm		
25° C (5.5)	-40° C (0.4)	60°	0.7	8.9	25.1	71.6	102.3	36.5	94.6	134.9	172.5	302.5	453.1	793.3		
				80°	9.2	25.9	74.0	105.9	37.8	97.8	139.6	178.5	312.9	468.8	820.7	
				100°	9.5	26.8	76.6	109.6	39.1	101.3	144.4	184.7	323.8	485.1	849.4	
		60°	1	10.7	30.5	87.3	126.4	44.5	116.4	167.1	214.1	373.4	560.8	979.1		
				80°	11.1	31.6	90.3	130.8	46.0	120.4	172.9	221.6	386.3	580.2	1013.0	
				100°	11.5	32.7	93.4	135.4	47.6	124.6	178.9	229.3	399.8	600.5	1048.4	
	25° C (5.5)	-20° C (2.1)	60°	0.7	9.6	27.2	77.8	111.2	39.7	102.8	146.6	187.5	328.7	492.4	862.0	
					80°	10.0	28.2	80.4	115.0	41.0	106.3	151.7	193.9	340.0	509.4	891.9
					100°	10.3	29.2	83.3	119.0	42.5	110.0	156.9	200.7	351.9	527.2	923.0
60°			1	11.6	33.1	94.7	137.2	48.2	126.3	181.3	232.4	405.2	608.6	1062.6		
				80°	12.1	34.3	98.0	142.0	49.9	130.7	187.6	240.4	419.3	629.7	1099.4	
				100°	12.5	35.5	101.4	146.9	51.7	135.3	194.2	248.8	433.9	651.7	1137.8	
25° C (5.5)	0° C (5.2)	60°	0.7	10.4	29.3	83.7	119.8	42.7	110.7	157.9	201.9	354.0	530.3	928.5		
				80°	10.8	30.4	86.6	123.9	44.2	114.5	163.3	208.9	366.2	548.7	960.6	
				100°	11.1	31.4	89.7	128.2	45.8	118.5	169.0	216.2	379.0	567.8	994.1	
		60°	1	12.5	35.6	101.9	147.6	51.9	135.9	195.1	250.1	436.0	654.9	1143.3		
				80°	13.0	36.9	105.4	152.7	53.7	140.6	201.9	258.7	451.1	677.5	1182.9	
				100°	13.4	38.2	109.1	158.1	55.6	145.6	208.9	267.7	466.9	701.2	1224.2	
30° C (6.7)	-40° C (0.4)	60°	0.7	8.0	22.5	64.1	91.3	32.7	84.4	120.2	153.7	269.8	404.0	707.8		
				80°	8.2	23.2	66.2	94.4	33.8	87.3	124.3	158.9	279.0	417.7	731.9	
				100°	8.5	24.0	68.5	97.6	35.0	90.3	128.6	164.4	288.7	432.1	757.2	
		60°	1	9.6	27.2	77.7	111.9	39.6	103.2	147.7	189.2	330.6	496.0	867.1		
				80°	9.9	28.1	80.4	115.7	41.0	106.7	152.8	195.6	341.9	512.9	896.7	
				100°	10.3	29.1	83.1	119.7	42.4	110.4	158.1	202.4	353.7	530.7	927.7	
	30° C (6.7)	-20° C (2.1)	60°	0.7	8.7	24.5	69.9	99.6	35.7	92.2	131.2	167.7	294.5	440.9	772.5	
					80°	9.0	25.3	72.3	103.0	36.9	95.3	135.7	173.4	304.5	455.9	798.8
					100°	9.3	26.2	74.8	106.6	38.2	98.6	140.4	179.4	315.0	471.6	826.4
			60°	1	10.5	29.6	84.7	122.0	43.2	112.5	161.0	206.2	360.4	540.7	945.2	
					80°	10.8	30.7	87.6	126.1	44.7	116.3	166.5	213.2	372.7	559.1	977.4
					100°	11.2	31.7	90.6	130.5	46.2	120.4	172.3	220.6	385.6	578.4	1011.2
30° C (6.7)	0° C (5.2)	60°	0.7	9.4	26.5	75.6	107.7	38.6	99.6	141.8	181.3	318.3	476.6	835.0		
				80°	9.7	27.4	78.2	111.3	39.9	103.0	146.7	187.4	329.2	492.8	863.4	
				100°	10.1	28.3	80.9	115.2	41.3	106.6	151.7	193.9	340.5	509.8	893.3	
		60°	1	11.3	32.0	91.5	131.7	46.6	121.5	173.9	222.6	389.2	583.9	1020.7		
				80°	11.7	33.1	94.6	136.2	48.2	125.6	179.8	230.2	402.4	603.8	1055.4	
				100°	12.1	34.3	97.9	140.9	49.9	130.0	186.0	238.2	416.4	624.6	1091.9	
35° C (7.8)	-40° C (0.4)	60°	0.7	7.2	20.3	58.0	82.4	29.6	76.3	108.4	138.5	243.5	364.3	638.8		
				80°	7.5	21.0	59.9	85.1	30.6	78.8	112.0	143.1	251.6	376.4	660.1	
				100°	7.7	21.7	62.0	88.0	31.6	81.5	115.8	148.0	260.2	389.3	682.6	
		60°	1	8.7	24.6	70.1	100.5	35.8	92.8	132.5	169.6	297.0	445.1	778.9		
				80°	9.0	25.4	72.4	103.8	37.0	95.9	137.0	175.2	306.9	460.0	804.9	
				100°	9.3	26.2	74.9	107.4	38.2	99.2	141.6	181.2	317.3	475.6	832.3	
	35° C (7.8)	-20° C (2.1)	60°	0.7	7.9	22.3	63.6	90.3	32.5	83.6	118.9	151.9	267.1	399.6	700.6	
					80°	8.2	23.0	65.7	93.3	33.6	86.4	122.9	156.9	276.0	412.8	723.9
					100°	8.5	23.8	68.0	96.5	34.7	89.4	127.0	162.3	285.4	426.9	748.6
			60°	1	9.5	26.9	76.8	110.1	39.2	101.7	145.2	185.7	325.3	487.6	853.2	
					80°	9.8	27.8	79.4	113.7	40.5	105.1	150.0	191.9	336.1	503.8	881.6
					100°	10.2	28.7	82.1	117.6	41.9	108.6	155.1	198.4	347.6	521.0	911.7
35° C (7.8)	0° C (5.2)	60°	0.7	8.6	24.2	69.0	98.0	35.2	90.8	129.0	164.8	289.9	433.6	760.3		
				80°	8.9	25.0	71.3	101.3	36.4	93.8	133.3	170.3	299.5	448.0	785.6	
				100°	9.2	25.9	73.7	104.7	37.7	97.0	137.9	176.1	309.7	463.3	812.4	
		60°	1	10.3	29.2	83.3	119.3	42.5	110.2	157.4	201.3	352.7	528.6	925.0		
				80°	10.7	30.1	86.0	123.3	43.9	113.9	162.6	208.0	364.4	546.2	955.8	
				100°	11.0	31.2	89.0	127.5	45.4	117.8	168.2	215.1	376.8	564.8	988.4	

A9, A8_0 Condenser Bypass Capacities - Tons R404A Refrigeration & Air Conditioning Control Valves

A9, A8 0 Condenser Bypass Capacities (Tons)													R404A		
Cond Temp (Sat pres) psig	Ev. Temp (Sat Pres) psig	Discharge Temp	Pres Drop psi	A9 3/8" 9 mm	A9 5/8" 15 mm	A9 7/8" 22 mm	A9 1-1/8" 28 mm	A8AOE 3/8" 9 mm	A8AOE 5/8" 15 mm	A8AOE 7/8" 22 mm	A81OE 1-1/8" 28 mm	A81OE 1-3/8" 35 mm	A82OE 1-5/8" 42 mm	A82OE 2-1/8" 54 mm	
75° F (161.2)	-40° F (5.5)	140°	10	2.2	6.2	17.7	25.0	9.1	23.2	32.9	42.0	74.0	110.6	194.2	
			180°	2.3	6.5	18.5	26.1	9.6	24.7	35.0	44.7	78.7	117.6	206.5	
				220°	2.4	6.8	19.2	27.2	10.0	25.7	36.5	46.6	82.1	122.7	215.3
		140°	15	180°	2.8	7.8	22.2	31.5	11.3	29.2	41.5	53.0	93.2	139.5	244.5
				180°	2.9	8.1	23.1	32.8	12.0	31.0	44.2	56.4	99.1	148.4	260.1
			220°	3.0	8.4	24.1	34.2	12.5	32.4	46.0	58.8	103.4	154.7	271.2	
75° F (161.2)	0° F (35.2)	140°	10	2.5	7.0	19.9	28.1	10.2	26.1	37.0	47.2	83.2	124.4	218.3	
			180°	2.6	7.3	20.8	29.3	10.8	27.8	39.3	50.2	88.5	132.2	232.2	
				220°	2.7	7.6	21.6	30.5	11.3	28.9	41.0	52.3	92.3	137.9	242.1
		140°	15	180°	3.1	8.7	24.9	35.4	12.7	32.8	46.6	59.5	104.6	156.6	274.4
				180°	3.2	9.1	25.9	36.9	13.5	34.8	49.6	63.3	111.3	166.5	291.9
			220°	3.4	9.5	27.0	38.4	14.1	36.3	51.7	66.0	116.0	173.6	304.3	
75° F (161.2)	40° F (87.8)	140°	10	2.7	7.7	21.9	31.0	11.2	28.7	40.8	52.0	91.7	137.0	240.5	
			180°	2.9	8.0	22.9	32.3	11.9	30.6	43.3	55.3	97.5	145.7	255.8	
				220°	3.0	8.4	23.8	33.7	12.4	31.9	45.2	57.7	101.7	151.9	266.7
		140°	15	180°	3.4	9.6	27.4	38.9	14.0	36.0	51.3	65.5	115.1	172.3	302.0
				180°	3.6	10.0	28.5	40.6	14.9	38.3	54.5	69.7	122.4	183.2	321.1
			220°	3.7	10.4	29.7	42.3	15.5	40.0	56.9	72.6	127.7	191.0	334.9	
95° F (219.4)	-40° F (5.5)	140°	10	1.6	4.6	13.0	18.4	6.7	17.0	24.1	30.8	54.3	81.1	142.5	
			180°	1.7	4.8	13.5	19.0	7.1	18.0	25.5	32.5	57.4	85.8	150.7	
				220°	1.8	4.9	14.1	19.8	7.3	18.8	26.6	33.9	59.8	89.3	156.9
		140°	15	180°	2.0	5.7	16.2	23.0	8.3	21.3	30.2	38.6	68.0	101.6	178.3
				180°	2.1	5.9	16.9	23.8	8.8	22.5	32.0	40.8	71.9	107.5	188.6
			220°	2.2	6.2	17.5	24.8	9.1	23.5	33.3	42.5	74.8	111.9	196.3	
95° F (219.4)	0° F (35.2)	140°	10	1.9	5.3	15.0	21.1	7.7	19.6	27.7	35.3	62.4	93.2	163.7	
			180°	2.0	5.5	15.5	21.9	8.1	20.7	29.3	37.4	66.0	98.5	173.2	
				220°	2.0	5.7	16.2	22.8	8.4	21.6	30.5	38.9	68.7	102.6	180.2
		140°	15	180°	2.3	6.5	18.6	26.3	9.5	24.4	34.7	44.2	77.9	116.5	204.4
				180°	2.4	6.8	19.3	27.3	10.1	25.8	36.7	46.8	82.4	123.2	216.3
			220°	2.5	7.1	20.1	28.4	10.5	26.9	38.2	48.7	85.8	128.3	225.1	
95° F (219.4)	40° F (87.8)	140°	10	2.1	5.9	16.8	23.6	8.6	21.9	31.0	39.5	69.8	104.3	183.2	
			180°	2.2	6.1	17.4	24.5	9.1	23.2	32.8	41.8	73.9	110.3	193.8	
				220°	2.3	6.4	18.1	25.5	9.4	24.1	34.1	43.5	76.9	114.8	201.7
		140°	15	180°	2.6	7.3	20.8	29.4	10.6	27.3	38.7	49.4	87.1	130.2	228.5
				180°	2.7	7.6	21.6	30.5	11.2	28.9	41.0	52.3	92.1	137.7	241.7
			220°	2.8	7.9	22.5	31.8	11.7	30.1	42.6	54.4	95.9	143.3	251.6	
115° F (290.4)	-40° F (5.5)	140°	10	1.2	3.3	9.4	13.2	4.8	12.3	17.4	22.1	39.1	58.4	102.7	
			180°	1.2	3.4	9.7	13.6	5.0	12.9	18.2	23.2	41.0	61.1	107.5	
				220°	1.3	3.5	10.0	14.1	5.2	13.4	18.9	24.1	42.5	63.5	111.6
		140°	15	180°	1.5	4.1	11.7	16.5	6.0	15.4	21.8	27.7	49.0	73.1	128.4
				180°	1.5	4.2	12.1	17.0	6.3	16.1	22.8	29.1	51.3	76.6	134.5
			220°	1.6	4.4	12.5	17.6	6.5	16.7	23.6	30.2	53.2	79.5	139.6	
115° F (290.4)	0° F (35.2)	140°	10	1.4	3.9	11.2	15.7	5.7	14.6	20.7	26.3	46.5	69.5	122.1	
			180°	1.4	4.1	11.5	16.2	6.0	15.3	21.6	27.6	48.7	72.7	127.9	
				220°	1.5	4.2	12.0	16.8	6.2	15.9	22.4	28.6	50.6	75.5	132.7
		140°	15	180°	1.7	4.9	13.9	19.6	7.1	18.2	25.8	32.9	58.1	86.8	152.4
				180°	1.8	5.0	14.3	20.2	7.5	19.1	27.0	34.5	60.8	90.8	159.6
			220°	1.9	5.2	14.9	20.9	7.7	19.8	28.0	35.8	63.1	94.3	165.6	
115° F (290.4)	40° F (87.8)	140°	10	1.6	4.5	12.9	18.0	6.6	16.8	23.7	30.2	53.4	79.7	140.1	
			180°	1.7	4.6	13.2	18.6	6.9	17.5	24.8	31.6	55.9	83.4	146.6	
				220°	1.7	4.8	13.7	19.2	7.1	18.2	25.7	32.8	58.0	86.6	152.2
		140°	15	180°	2.0	5.6	15.9	22.5	8.1	20.9	29.5	37.7	66.5	99.3	174.4
				180°	2.1	5.8	16.4	23.1	8.5	21.8	30.9	39.4	69.6	104.0	182.6
			220°	2.1	6.0	17.0	24.0	8.9	22.7	32.1	40.9	72.2	107.9	189.5	



A9, A8_0 Condenser Bypass Capacities (Kilowatts)

R404A

Cond Temp (Sat Pres) bar	Ev. Temp (Sat Pres) bar	Discharge Temp	Pres Drop bar	A9 3/8" 9 mm	A9 5/8" 15 mm	A9 7/8" 22 mm	A9 1-1/8" 28 mm	A8AOE 3/8" 9 mm	A8AOE 5/8" 15 mm	A8AOE 7/8" 22 mm	A81OE 1-1/8" 28 mm	A81OE 1-3/8" 35 mm	A82OE 1-5/8" 42 mm	A82OE 2-1/8" 54 mm	
25° C (11.2)	-40° C (0.4)	60° 80° 100°	0.7	8.0 8.3 8.6	22.4 23.3 24.2	63.9 66.3 68.9	90.1 93.6 97.3	32.6 33.9 35.2	83.6 86.8 90.2	118.5 123.1 127.9	151.2 157.0 163.2	266.7 276.9 287.7	398.5 413.7 429.9	699.6 726.4 754.8	
			1	0.7	9.7 10.1 10.5	27.3 28.3 29.4	77.8 80.8 84.0	110.5 114.8 119.3	39.7 41.3 42.9	102.4 106.3 110.4	145.5 151.1 157.0	185.9 193.0 200.6	326.9 339.4 352.7	489.1 507.8 527.7	857.5 890.4 925.2
				1	0.7	8.9 9.2 9.6	25.0 25.9 26.9	71.1 73.9 76.8	100.4 104.3 108.4	36.4 37.8 39.2	93.2 96.7 100.5	132.1 137.1 142.5	168.5 175.0 181.8	297.1 308.5 320.5	443.9 460.9 479.0
		1			0.7	10.8 11.2 11.6	30.4 31.5 32.8	86.6 89.9 93.4	123.0 127.7 132.7	44.2 45.9 47.7	113.9 118.3 122.9	161.9 168.1 174.7	206.8 214.8 223.2	363.7 377.6 392.4	544.1 565.0 587.1
			1		0.7	9.8 10.1 10.5	27.3 28.4 29.5	77.9 80.9 84.1	110.0 114.2 118.7	39.8 41.4 43.0	102.1 106.0 110.1	144.7 150.2 156.1	184.6 191.7 199.2	325.5 337.9 351.1	486.3 505.0 524.7
				1	0.7	11.8 12.3 12.7	33.2 34.5 35.8	94.7 98.4 102.2	134.6 139.8 145.2	48.4 50.2 52.2	124.6 129.4 134.5	177.2 184.0 191.2	226.4 235.0 244.2	398.0 413.3 429.4	595.5 618.3 642.5
30° C (13.1)	-40° C (0.4)	60° 80° 100°			0.7	6.9 7.2 7.4	19.3 20.0 20.8	55.1 57.1 59.3	77.6 80.5 83.5	28.1 29.2 30.3	72.0 74.7 77.5	102.0 105.8 109.8	130.1 134.9 140.1	229.6 238.0 247.1	342.9 355.6 369.1
			1		0.7	8.4 8.7 9.0	23.5 24.3 25.3	66.9 69.4 72.0	94.8 98.3 102.1	34.2 35.4 36.8	87.9 91.1 94.6	124.8 129.4 134.3	159.3 165.2 171.5	280.5 290.8 301.9	419.4 434.9 451.5
				1	0.7	7.8 8.0 8.3	21.7 22.5 23.4	61.9 64.1 66.6	87.2 90.4 93.8	31.6 32.8 34.0	80.9 83.9 87.1	114.6 118.8 123.3	146.2 151.5 157.3	257.9 267.4 277.6	385.2 399.4 414.7
		1			0.7	9.4 9.7 10.1	26.3 27.3 28.3	75.1 77.8 80.8	106.4 110.3 114.5	38.3 39.8 41.3	98.6 102.2 106.1	140.0 145.1 150.7	178.7 185.3 192.4	314.6 326.2 338.6	470.4 487.8 506.4
			1		0.7	8.5 8.9 9.2	23.9 24.8 25.8	68.2 70.7 73.4	96.1 99.6 103.4	34.9 36.1 37.5	89.2 92.5 96.0	126.3 131.0 136.0	161.1 167.1 173.4	284.3 294.8 306.0	424.7 440.3 457.1
				1	0.7	10.3 10.7 11.1	29.0 30.1 31.2	82.7 85.7 89.0	117.1 121.4 126.1	42.2 43.8 45.5	108.5 112.5 116.8	154.1 159.8 165.9	196.8 204.0 211.8	346.4 359.2 372.9	518.0 537.1 557.6
35° C (15.1)	-40° C (0.4)	60° 80° 100°			0.7	6.0 6.2 6.4	16.7 17.3 18.0	47.7 49.3 51.2	67.1 69.4 72.0	24.4 25.2 26.2	62.3 64.5 66.9	88.2 91.2 94.6	112.4 116.4 120.7	198.5 205.5 213.1	296.5 306.8 318.2
			1		0.7	7.2 7.5 7.8	20.3 21.0 21.8	57.9 59.9 62.1	81.8 84.7 87.8	29.6 30.6 31.7	75.9 78.5 81.4	107.6 111.4 115.5	137.4 142.2 147.4	242.1 250.5 259.8	361.8 374.4 388.3
				1	0.7	6.8 7.0 7.3	19.0 19.7 20.4	54.1 56.0 58.1	76.1 78.8 81.7	27.7 28.6 29.7	70.7 73.1 75.9	100.0 103.5 107.4	127.6 132.0 136.9	225.2 233.1 241.7	336.3 348.1 361.0
		1			0.7	8.2 8.5 8.8	23.0 23.8 24.7	65.5 67.8 70.4	92.7 95.9 99.5	33.5 34.7 35.9	85.9 88.9 92.2	121.9 126.2 130.8	155.6 161.0 167.0	274.2 283.7 294.3	409.8 424.1 439.8
			1		0.7	7.5 7.8 8.1	21.1 21.8 22.6	60.1 62.2 64.5	84.5 87.5 90.7	30.7 31.8 33.0	78.5 81.2 84.2	111.1 115.0 119.2	141.7 146.6 152.0	250.1 258.9 268.5	373.5 386.6 400.9
				1	0.7	9.1 9.4 9.8	25.5 26.4 27.4	72.7 75.3 78.0	102.8 106.4 110.3	37.2 38.5 39.9	95.3 98.7 102.3	135.2 140.0 145.1	172.6 178.6 185.2	304.1 314.7 326.4	454.6 470.4 487.9



A9, A8_0 Condenser Bypass Capacities (Tons) R507

Cond Temp (Sat pres) psig	Ev. Temp (Sat Pres) psig	Discharge Temp	Pres Drop psi	A9	A9	A9	A9	A8AOE	A8AOE	A8AOE	A81OE	A81OE	A82OE	A82OE	
				3/8" 9 mm	5/8" 15 mm	7/8" 22 mm	1-1/8" 28 mm	3/8" 9 mm	5/8" 15 mm	7/8" 22 mm	1-1/8" 28 mm	1-3/8" 35 mm	1-5/8" 42 mm	2-1/8" 54 mm	
75° F (167)	-40° F (5.5)	140°	10	2.3	6.4	18.4	25.9	9.4	24.0	34.1	43.5	76.6	114.5	201.0	
				180°	2.4	6.7	19.2	27.1	10.0	25.7	36.4	46.4	81.9	122.4	214.9
				220°	2.5	7.0	20.1	28.3	10.5	26.8	38.0	48.5	85.6	127.8	224.5
		140°	15	2.8	8.0	22.8	32.5	11.7	30.1	42.8	54.6	96.0	143.7	251.9	
				180°	3.0	8.4	23.9	34.0	12.5	32.1	45.7	58.4	102.7	153.6	269.3
				220°	3.1	8.8	25.0	35.5	13.0	33.6	47.8	61.0	107.2	160.5	281.3
75° F (167)	0° F (35.2)	140°	10	2.6	7.2	20.5	28.9	10.5	26.8	38.0	48.5	85.6	127.9	224.6	
				180°	2.7	7.5	21.4	30.3	11.2	28.7	40.7	51.9	91.5	136.7	240.1
				220°	2.8	7.9	22.4	31.6	11.7	30.0	42.5	54.2	95.6	142.8	250.8
		140°	15	3.2	8.9	25.5	36.2	13.0	33.5	47.7	60.9	107.1	160.3	281.0	
				180°	3.3	9.3	26.7	37.9	13.9	35.9	51.0	65.2	114.5	171.4	300.4
				220°	3.5	9.8	27.9	39.6	14.5	37.5	53.3	68.1	119.6	179.0	313.9
75° F (167)	40° F (87.8)	140°	10	2.8	7.9	22.5	31.8	11.5	29.5	41.8	53.3	94.1	140.6	246.8	
				180°	2.9	8.3	23.6	33.2	12.3	31.5	44.7	57.0	100.6	150.2	263.8
				220°	3.1	8.6	24.6	34.7	12.9	32.9	46.7	59.6	105.1	157.0	275.6
		140°	15	3.5	9.8	28.0	39.8	14.3	36.8	52.4	66.9	117.6	176.0	308.5	
				180°	3.6	10.3	29.3	41.6	15.3	39.4	56.0	71.5	125.7	188.1	329.8
				220°	3.8	10.7	30.6	43.5	16.0	41.1	58.5	74.7	131.3	196.5	344.5
95° F (226)	-40° F (5.5)	140°	10	1.8	5.0	14.1	19.8	7.2	18.4	26.1	33.2	58.7	87.6	154.0	
				180°	1.8	5.2	14.7	20.7	7.7	19.6	27.8	35.4	62.5	93.3	164.0
				220°	1.9	5.4	15.3	21.6	8.0	20.5	29.0	36.9	65.2	97.4	171.1
		140°	15	2.2	6.1	17.5	24.7	8.9	22.9	32.5	41.5	73.1	109.3	191.8	
				180°	2.3	6.4	18.2	25.8	9.5	24.4	34.7	44.2	77.9	116.5	204.4
				220°	2.4	6.7	19.0	26.9	9.9	25.5	36.2	46.1	81.3	121.5	213.3
95° F (226)	0° F (35.2)	140°	10	2.0	5.6	16.0	22.6	8.2	20.9	29.6	37.8	66.7	99.7	175.1	
				180°	2.1	5.9	16.7	23.5	8.7	22.3	31.6	40.3	71.1	106.2	186.6
				220°	2.2	6.1	17.5	24.5	9.1	23.3	32.9	42.0	74.2	110.8	194.7
		140°	15	2.5	7.0	19.9	28.1	10.1	26.0	36.9	47.1	83.0	124.1	217.9	
				180°	2.6	7.3	20.7	29.3	10.8	27.7	39.3	50.2	88.5	132.3	232.1
				220°	2.7	7.6	21.6	30.6	11.3	28.9	41.1	52.4	92.3	138.0	242.2
95° F (226)	40° F (87.8)	140°	10	2.2	6.3	17.9	25.1	9.1	23.3	33.0	42.1	74.3	111.0	195.1	
				180°	2.3	6.5	18.6	26.2	9.7	24.9	35.2	44.9	79.2	118.3	207.8
				220°	2.4	6.8	19.4	27.3	10.2	25.9	36.7	46.8	82.6	123.4	216.8
		140°	15	2.8	7.8	22.1	31.2	11.3	29.0	41.1	52.4	92.4	138.1	242.4	
				180°	2.9	8.1	23.0	32.6	12.0	30.9	43.8	55.9	98.4	147.2	258.3
				220°	3.0	8.4	24.0	34.0	12.6	32.2	45.7	58.3	102.7	153.5	269.5
115° F (301)	-40° F (5.5)	140°	10	1.3	3.7	10.7	15.0	5.5	13.9	19.7	25.1	44.3	66.1	116.3	
				180°	1.4	3.9	11.1	15.5	5.8	14.7	20.8	26.5	46.9	70.0	123.0
				220°	1.4	4.0	11.5	16.2	6.0	15.3	21.7	27.6	48.8	72.8	128.1
		140°	15	1.7	4.7	13.2	18.7	6.8	17.3	24.5	31.3	55.2	82.5	144.9	
				180°	1.7	4.8	13.7	19.4	7.2	18.3	26.0	33.1	58.4	87.3	153.3
				220°	1.8	5.0	14.3	20.1	7.5	19.1	27.0	34.5	60.8	90.9	159.6
115° F (301)	0° F (35.2)	140°	10	1.6	4.4	12.5	17.5	6.4	16.3	23.0	29.3	51.8	77.3	136.0	
				180°	1.6	4.5	12.9	18.2	6.8	17.2	24.3	31.0	54.8	81.8	143.8
				220°	1.7	4.7	13.5	18.9	7.0	17.9	25.3	32.3	57.1	85.2	149.7
		140°	15	1.9	5.4	15.5	21.8	7.9	20.2	28.6	36.5	64.4	96.2	169.0	
				180°	2.0	5.6	16.0	22.6	8.4	21.4	30.3	38.6	68.2	101.8	178.8
				220°	2.1	5.9	16.7	23.5	8.7	22.3	31.5	40.2	71.0	106.0	186.2
115° F (301)	40° F (87.8)	140°	10	1.8	5.0	14.2	19.9	7.3	18.5	26.1	33.3	58.9	87.9	154.5	
				180°	1.8	5.2	14.7	20.6	7.7	19.6	27.6	35.2	62.3	93.0	163.5
				220°	1.9	5.4	15.3	21.5	8.0	20.4	28.8	36.7	64.9	96.8	170.2
		140°	15	2.2	6.2	17.5	24.7	9.0	22.9	32.5	41.4	73.1	109.2	191.8	
				180°	2.3	6.4	18.2	25.6	9.5	24.3	34.4	43.8	77.4	115.5	203.0
				220°	2.4	6.6	18.9	26.7	9.9	25.3	35.8	45.6	80.5	120.3	211.3

A9, A8 0 Condenser Bypass Capacities (Kilowatts)

R507

Cond Temp (Sat Pres) bar	Ev. Temp (Sat Pres) bar	Discharge Temp	Pres Drop bar	A9	A9	A9	A9	A8AOE	A8AOE	A8AOE	A81OE	A81OE	A82OE	A82OE		
				3/8" 9 mm	5/8" 15 mm	7/8" 22 mm	1-1/8" 28 mm	3/8" 9 mm	5/8" 15 mm	7/8" 22 mm	1-1/8" 28 mm	1-3/8" 35 mm	1-5/8" 42 mm	2-1/8" 54 mm		
25° C (11.6)	-40° C (0.4)	60°	0.7	8.3	23.4	66.6	94.0	34.0	87.2	123.6	157.7	278.1	415.5	729.6		
				80°	8.7	24.4	69.4	98.0	35.5	90.9	128.8	164.3	289.8	433.0	760.3	
				100°	9.1	25.4	72.3	102.0	37.0	94.7	134.2	171.2	301.9	451.0	792.0	
		60°	1	10.1	28.4	80.9	114.8	41.3	106.3	151.1	193.0	339.5	507.8	890.5		
				80°	10.5	29.6	84.3	119.6	43.0	110.8	157.5	201.2	353.8	529.3	928.1	
				100°	10.9	30.8	87.8	124.6	44.8	115.4	164.1	209.5	368.5	551.3	966.8	
	-20° C (2.1)	60°	0.7	9.2	25.9	73.8	104.1	37.7	96.6	136.9	174.6	307.9	460.1	807.9		
				80°	9.6	27.0	76.9	108.5	39.3	100.6	142.6	182.0	320.9	479.5	841.9	
				100°	10.0	28.1	80.1	113.0	40.9	104.8	148.6	189.5	334.3	499.4	877.0	
		60°	1	11.2	31.4	89.4	127.0	45.7	117.6	167.1	213.5	375.5	561.7	985.0		
				80°	11.6	32.7	93.2	132.3	47.6	122.6	174.2	222.5	391.3	585.4	1026.5	
				100°	12.1	34.1	97.1	137.8	49.6	127.7	181.4	231.7	407.6	609.8	1069.3	
25° C (11.6)	0° C (5.2)	60°	0.7	10.1	28.3	80.6	113.7	41.2	105.5	149.5	190.7	336.3	502.4	882.3		
				80°	10.5	29.5	84.0	118.5	42.9	109.9	155.8	198.7	350.5	523.6	919.4	
				100°	10.9	30.7	87.5	123.4	44.7	114.5	162.2	207.0	365.0	545.4	957.7	
		60°	1	12.2	34.2	97.6	138.5	49.8	128.3	182.4	232.9	409.7	612.9	1074.7		
				80°	12.7	35.7	101.7	144.4	51.9	133.7	190.1	242.8	427.0	638.7	1120.0	
				100°	13.2	37.2	105.9	150.4	54.1	139.3	198.0	252.9	444.8	665.3	1166.7	
	30° C (13.5)	-40° C (0.4)	60°	0.7	7.3	20.6	58.6	82.5	29.9	76.6	108.5	138.4	244.2	364.7	640.7	
					80°	7.6	21.4	61.0	85.9	31.2	79.8	113.0	144.1	254.3	379.8	667.1
					100°	8.0	22.3	63.5	89.5	32.5	83.1	117.6	150.0	264.7	395.4	694.5
			60°	1	8.9	24.9	70.9	100.5	36.2	93.1	132.2	168.8	297.1	444.3	779.5	
					80°	9.2	25.9	73.9	104.6	37.7	97.0	137.7	175.7	309.4	462.6	811.7
					100°	9.6	27.0	76.9	108.9	39.3	101.0	143.3	183.0	322.1	481.7	845.1
-20° C (2.1)		60°	0.7	8.2	22.9	65.3	92.0	33.4	85.4	120.9	154.3	272.2	406.6	714.3		
				80°	8.5	23.9	68.0	95.8	34.8	88.9	125.9	160.6	283.5	423.4	743.7	
				100°	8.9	24.9	70.8	99.8	36.2	92.6	131.1	167.2	295.1	440.8	774.3	
		60°	1	9.9	27.7	79.0	111.9	40.4	103.7	147.2	187.9	330.9	494.8	868.0		
				80°	10.3	28.9	82.3	116.5	42.0	108.0	153.3	195.7	344.6	515.2	903.9	
				100°	10.7	30.0	85.7	121.3	43.8	112.4	159.6	203.7	358.7	536.4	941.1	
30° C (13.5)	0° C (5.2)	60°	0.7	9.0	25.2	71.7	101.0	36.7	93.8	132.8	169.4	298.9	446.5	784.3		
				80°	9.4	26.2	74.7	105.2	38.2	97.7	138.3	176.4	311.3	464.9	816.6	
				100°	9.7	27.3	77.8	109.5	39.7	101.7	144.0	183.6	324.0	484.0	850.2	
		60°	1	10.8	30.4	86.7	122.7	44.3	113.7	161.5	206.2	363.0	542.7	952.2		
				80°	11.3	31.7	90.2	127.8	46.1	118.4	168.2	214.7	378.0	565.2	991.6	
				100°	11.7	33.0	94.0	133.1	48.0	123.3	175.1	223.5	393.5	588.4	1032.3	
	35° C (15.6)	-40° C (0.4)	60°	0.7	6.5	18.2	51.7	72.8	26.5	67.6	95.6	122.0	215.4	321.6	565.0	
					80°	6.8	18.9	53.8	75.7	27.5	70.3	99.5	126.8	224.0	334.4	587.7
					100°	7.0	19.7	56.0	78.8	28.6	73.1	103.5	132.0	233.0	347.9	611.4
			60°	1	7.8	22.0	62.6	88.4	32.0	82.0	116.3	148.4	261.6	391.0	686.3	
					80°	8.1	22.8	65.1	92.0	33.3	85.3	121.0	154.4	272.1	406.7	713.8
					100°	8.5	23.8	67.7	95.7	34.6	88.7	125.9	160.6	283.1	423.1	742.6
-20° C (2.1)		60°	0.7	7.3	20.4	58.1	81.8	29.7	76.0	107.5	137.1	242.1	361.4	635.1		
				80°	7.6	21.2	60.5	85.1	30.9	79.0	111.8	142.6	251.8	375.9	660.5	
				100°	7.9	22.1	62.9	88.5	32.2	82.2	116.3	148.3	261.9	391.1	687.1	
		60°	1	8.8	24.6	70.2	99.3	35.9	92.1	130.6	166.6	293.6	438.9	770.4		
				80°	9.1	25.6	73.1	103.3	37.3	95.8	135.8	173.3	305.4	456.5	801.3	
				100°	9.5	26.7	76.0	107.4	38.8	99.6	141.3	180.3	317.8	474.9	833.6	
35° C (15.6)	0° C (5.2)	60°	0.7	8.1	22.6	64.2	90.4	32.8	83.9	118.8	151.5	267.4	399.3	701.7		
				80°	8.4	23.5	66.8	94.0	34.2	87.3	123.5	157.5	278.2	415.3	729.8	
				100°	8.7	24.4	69.5	97.8	35.5	90.8	128.5	163.9	289.4	432.1	759.2	
		60°	1	9.7	27.2	77.5	109.6	39.6	101.6	144.1	183.9	324.1	484.4	850.3		
				80°	10.1	28.3	80.6	114.0	41.2	105.7	149.9	191.3	337.1	503.9	884.4	
				100°	10.5	29.4	83.9	118.6	42.9	110.0	155.9	199.0	350.7	524.2	920.1	

Hot Gas Bypass

Hot gas bypass is a method of compressor capacity control that has been utilized in the refrigeration and air conditioning industry for many years. A significant number of refrigeration and air conditioning systems operate at full capacity no more than 20% of their running time. As a result, many compressors operating above fifteen horsepower are equipped with cylinder unloading devices whereby the capacity of the compressor can effectively be reduced. The need for automatic hot gas bypass becomes evident, however, for those systems having compressors that do not possess cylinder unloading, or for those systems with unloading capability, but without or lacking suction pressure control between the last stage of unloading and 0% capacity.

A hot gas bypass system is designed to artificially load the compressor upon a decrease in evaporator load for one or more of the following reasons:

- To prevent the operation of the compressor at unacceptably low suction pressures, which could result in oil pumping, compressor cycling, temperature variation, and eventual compressor or motor failure.
- To prevent a significant drop in evaporator temperature where constant conditions are required.
- To prevent the frosting of the evaporator coil, which can cause a loss of capacity due to the restricted air flow.

Basic hot gas bypass systems are illustrated in Figures 3 and 4.

A portion of the refrigerant discharge gas is bypassed around the condenser and thermostatic expansion valve, effectively reducing the flow of refrigerant available for cooling. In addition to the reduction in refrigeration effect due to the reduced liquid refrigerant flow through the condenser and expansion valve, the heat content of the hot gas bypassed compared to the suction gas will add load, further reducing the refrigeration effect of the evaporator.

Compressor suction pressure is the principal condition being controlled with any hot gas bypass system. Therefore, whenever discharge gas is introduced into the inlet of the evaporator by means of a hot gas bypass regulator, the regulator must be used with an external equalizer connected to the compressor suction main, and at a point downstream of any evaporator pressure regulator which may be used. In this manner, any pressure drop conditions due to distributors, evaporator circuiting, or valves will not affect the operation of the hot gas bypass regulator.

The two commercial regulators recommended for hot gas bypass applications are the Refrigerating Specialties A9E, and A8_OE series. The A9E is physically the smaller of the two valve types, covering port sizes of 3/8" through 1-1/8", and was originally designed specifically for hot gas bypass applications. The A8 series covers three different body sizes, the A8AOE, A81OE, and A82OE, and cover a much larger capacity range, with port sizes as large as 2 1/8".

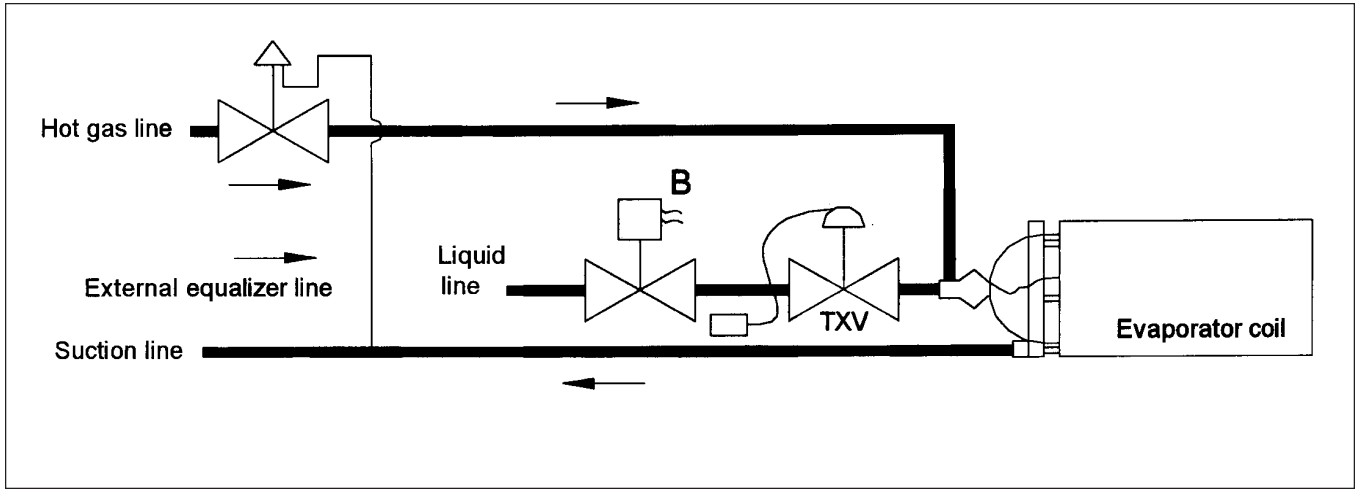

Figure 3 - Hot gas bypass to entrance of evaporator. (See page 72 for symbols legend).

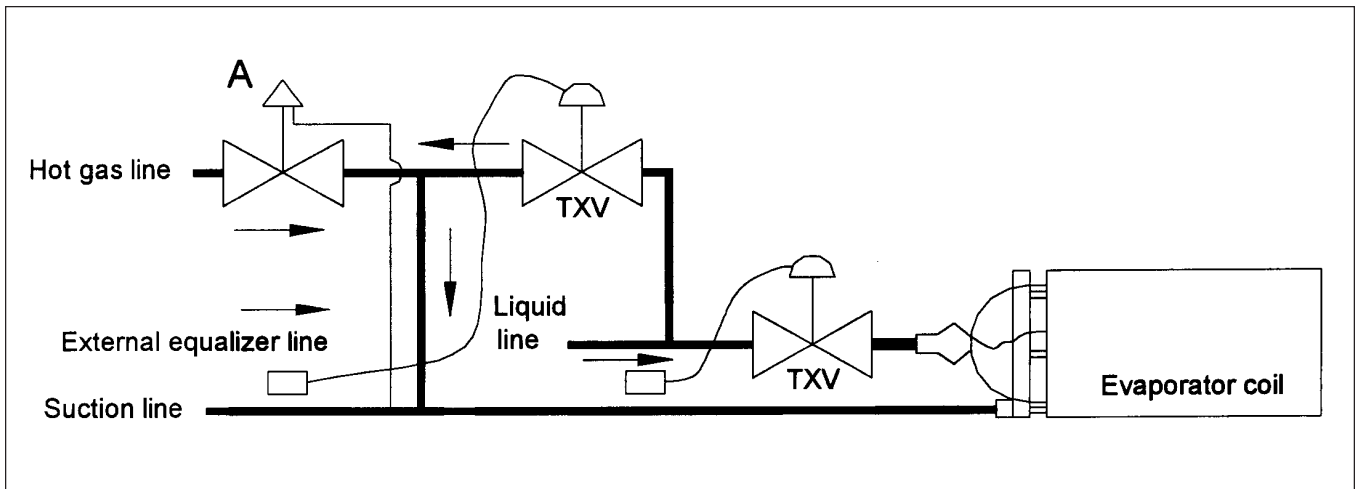

Figure 4 - Hot gas bypass to suction with liquid injection. (See page 72 for symbols legend).

Valve Legend				
Label	Valve Function	Application	Design	Selection Page
A	Outlet Pressure Regulator	Hot Gas Bypass	A9 or A8_OE	58-61
B	Solenoid Valve	Liquid Feed	SC	65

Hot Gas Bypass Capacities in Tons

R22

Cond. Temp.	Discharge Temp	A9 3/8	A9 5/8	A9 7/8	A9 1-1/8	A8AOE 3/8	A8AOE 5/8	A8AOE 7/8	A81OE 1-1/8	A81OE 1-3/8	A82OE 1-5/8	A82OE 2-1/8
86° F	140° F	1.4	4.1	12.0	19.1	6.0	17.1	25.8	33.6	56.2	86.0	147.0
	180° F	1.5	4.3	12.4	19.9	6.3	17.8	26.8	34.9	58.4	89.4	152.8
	220° F	1.5	4.5	12.9	20.6	6.5	18.5	27.8	36.2	60.6	92.7	158.6
100° F	140° F	1.6	4.8	13.8	22.3	7.0	19.8	30.3	39.8	65.3	100.9	170.9
	180° F	1.7	5.0	14.4	23.3	7.3	20.7	31.7	41.6	68.3	105.5	178.7
	220° F	1.8	5.2	15.0	24.3	7.6	21.6	33.1	43.4	71.2	110.0	186.3
110° F	140° F	1.8	5.2	15.1	24.4	7.6	21.7	33.2	43.8	71.5	110.5	187.0
	180° F	1.9	5.5	15.9	25.7	8.0	22.8	34.9	46.0	75.1	116.1	196.5
	220° F	1.9	5.7	16.6	26.9	8.4	23.8	36.5	48.1	78.7	121.5	205.8
120° F	140° F	1.9	5.7	16.4	26.5	8.2	23.5	36.0	47.5	77.5	119.8	202.8
	180° F	2.0	6.0	17.3	28.0	8.7	24.8	38.1	50.2	81.9	126.6	214.4
	220° F	2.1	6.3	18.2	29.4	9.2	26.1	40.0	52.8	86.2	133.2	225.5

Hot Gas Bypass Capacities in Tons

R134a

Cond Temp'	Discharge Temp	A9 3/8	A9 5/8	A9 7/8	A9 1-1/8	A8AOE 3/8	A8AOE 5/8	A8AOE 7/8	A81OE 1-1/8	A81OE 1-3/8	A82OE 1-5/8	A82OE 2-1/8
86° F	140° F	1.0	2.8	8.2	13.2	4.1	11.8	17.9	23.4	38.8	59.7	101.5
	180° F	1.0	3.0	8.7	14.1	4.4	12.5	19.0	24.9	41.3	63.5	108.0
	220° F	1.1	3.2	9.2	14.9	4.7	13.3	20.2	26.4	43.7	67.3	114.4
100° F	140° F	1.1	3.3	9.6	15.5	4.8	13.8	21.1	27.9	45.5	70.3	119.1
	180° F	1.2	3.6	10.3	16.6	5.2	14.8	22.7	29.8	48.8	75.3	127.6
	220° F	1.3	3.8	11.0	17.7	5.5	15.7	24.1	31.8	52.0	80.3	135.9
110° F	140° F	1.2	3.7	10.6	17.2	5.4	15.3	23.4	30.8	50.4	77.8	131.7
	180° F	1.3	4.0	11.5	18.5	5.8	16.5	25.2	33.2	54.3	83.9	142.0
	220° F	1.4	4.2	12.3	19.8	6.2	17.6	27.0	35.6	58.1	89.8	152.1
120° F	140° F	1.4	4.0	11.6	18.8	5.9	16.7	25.6	33.7	55.1	85.2	144.2
	180° F	1.5	4.4	12.6	20.5	6.4	18.2	27.8	36.7	59.9	92.6	156.7
	220° F	1.6	4.7	13.6	22.0	6.9	19.5	30.0	39.5	64.5	99.7	168.7

Hot Gas Bypass Capacities in Kilowatts

R134a

Cond Temp.	Discharge Temp	A9 9 mm	A9 15 mm	A9 22 mm	A9 28 mm	A8AOE 9 mm	A8AOE 15 mm	A8AOE 22 mm	A81OE 28 mm	A81OE 35 mm	A82OE 42 mm	A82OE 54 mm
30° C	60° C	4.4	12.4	28.9	46.6	14.5	41.4	63.0	82.3	136.5	210.0	357.1
	90° C	4.6	13.4	30.5	49.2	15.4	43.8	66.6	87.0	144.3	222.0	377.6



Hot Gas Bypass Capacities in Kilowatts

R22

Cond. Temp.	Discharge Temp	A9 9 mm	A9 15 mm	A9 22 mm	A9 28 mm	A8AOE 9 mm	A8AOE 15 mm	A8AOE 22 mm	A81OE 28 mm	A81OE 35 mm	A82OE 42 mm	A82OE 54 mm
30° C	60° C	4.9	14.6	42.1	67.3	21.2	60.2	90.6	118.0	197.5	302.5	517.1
	80° C	5.1	15.1	43.6	69.7	22.0	62.4	93.8	122.1	204.5	313.1	535.4
	100° C	5.3	15.6	45.1	72.0	22.7	64.5	97.0	126.3	211.5	323.8	553.7
40° C	60° C	5.9	17.4	50.3	81.4	25.4	72.2	110.8	145.8	238.4	368.4	623.7
	80° C	6.1	18.2	52.5	84.9	26.5	75.3	115.5	152.0	248.6	384.2	650.4
	100° C	6.4	18.9	54.6	88.3	27.5	78.4	120.2	158.1	258.7	399.7	676.6
45° C	60° C	6.4	18.8	54.5	88.1	27.4	78.1	119.8	157.9	257.9	398.6	674.7
	80° C	6.7	19.7	57.0	92.2	28.7	81.8	125.5	165.4	270.1	417.4	706.7
	100° C	7.0	20.6	59.5	96.3	30.0	85.4	131.0	172.6	282.0	435.7	737.6
50° C	60° C	6.8	20.2	58.4	94.5	29.4	83.8	128.6	169.4	276.7	427.6	723.9
	80° C	7.2	21.3	61.5	99.5	31.0	88.3	135.4	178.4	291.4	450.3	762.2
	100° C	7.5	22.3	64.5	104.3	32.5	92.5	141.9	187.0	305.4	471.9	798.9

Hot Gas Bypass Capacities in Kilowatts

R134a

Cond Temp.	Discharge Temp	A9 9 mm	A9 15 mm	A9 22 mm	A9 28 mm	A8AOE 9 mm	A8AOE 15 mm	A8AOE 22 mm	A81OE 28 mm	A81OE 35 mm	A82OE 42 mm	A82OE 54 mm
30° C	60° C	3.4	10.0	28.9	46.6	14.5	41.4	63.0	82.3	136.5	210.0	357.1
	80° C	3.6	10.6	30.5	49.2	15.4	43.8	66.6	87.0	144.3	222.0	377.6
	100° C	3.8	11.1	32.2	51.9	16.2	46.1	70.2	91.7	152.1	233.9	398.0
40° C	60° C	4.1	12.2	35.2	57.0	17.8	50.5	77.5	102.1	166.8	257.8	436.4
	80° C	4.4	13.0	37.6	60.8	18.9	53.9	82.7	108.9	178.0	275.0	465.5
	100° C	4.7	13.8	39.9	64.5	20.1	57.2	87.7	115.6	188.9	291.8	494.0
45° C	60° C	4.5	13.3	38.5	62.2	19.4	55.2	84.6	111.5	182.2	281.5	476.6
	80° C	4.8	14.3	41.3	66.7	20.8	59.2	90.8	119.6	195.4	302.0	511.2
	100° C	5.1	15.2	44.0	71.1	22.2	63.1	96.8	127.5	208.3	321.8	544.8
50° C	60° C	4.9	14.4	41.6	67.3	21.0	59.7	91.6	120.7	197.2	304.7	515.8
	80° C	5.3	15.6	45.0	72.7	22.7	64.5	99.0	130.4	213.0	329.1	557.2
	100° C	5.6	16.7	48.2	77.9	24.3	69.1	106.0	139.6	228.1	352.5	596.7

Hot Gas Bypass Capacities in Tons

R404A

Cond Temp'	Discharge Temp	A9 3/8	A9 5/8	A9 7/8	A9 1-1/8	A8AOE 3/8	A8AOE 5/8	A8AOE 7/8	A81OE 1-1/8	A81OE 1-3/8	A82OE 1-5/8	A82OE 2-1/8
86° F	140° F	1.5	4.4	12.6	20.2	6.3	18.0	27.2	35.5	59.2	90.8	155.0
	180° F	1.6	4.7	13.6	21.8	6.9	19.5	29.4	38.3	63.9	98.0	167.3
	220° F	1.7	5.1	14.6	23.4	7.4	20.9	31.5	41.1	68.6	105.2	179.6
100° F	140° F	1.6	4.9	14.0	22.7	7.1	20.1	30.8	40.5	66.4	102.6	173.6
	180° F	1.8	5.3	15.3	24.8	7.7	22.0	33.7	44.3	72.5	112.1	189.7
	220° F	1.9	5.7	16.6	26.8	8.4	23.8	36.5	48.0	78.6	121.4	205.5
110° F	140° F	1.7	5.1	14.9	24.0	7.5	21.3	32.7	43.1	70.3	108.7	184.0
	180° F	1.9	5.7	16.4	26.5	8.3	23.6	36.1	47.6	77.8	120.1	203.4
	220° F	2.1	6.2	17.9	29.0	9.0	25.7	39.5	52.0	85.0	131.3	222.2
120° F	140° F	1.8	5.3	15.4	24.9	7.8	22.1	33.9	44.6	72.9	112.7	190.7
	180° F	2.0	6.0	17.3	28.0	8.7	24.9	38.1	50.2	82.0	126.8	214.6
	220° F	2.2	6.6	19.1	31.0	9.6	27.5	42.1	55.5	90.7	140.1	237.2

Hot Gas Bypass Capacities in Tons

R507

Cond Temp'	Discharge Temp	A9 3/8	A9 5/8	A9 7/8	A9 1-1/8	A8_OE 3/8	A8_OE 5/8	A8_OE 7/8	A8_OE 1-1/8	A8_OE 1-3/8	A8_OE 1-5/8	A8_OE 2-1/8
86° F	140° F	1.5	4.6	13.2	21.1	6.6	18.9	28.5	37.1	62.0	95.0	162.3
	180° F	1.7	4.9	14.3	22.9	7.2	20.5	30.8	40.2	67.2	102.9	175.8
	220° F	1.8	5.3	15.4	24.6	7.7	22.0	33.2	43.2	72.2	110.6	189.0
100° F	140° F	1.7	5.1	14.8	24.0	7.5	21.3	32.6	42.9	70.3	108.6	183.8
	180° F	1.9	5.6	16.3	26.3	8.2	23.3	35.8	47.0	77.0	119.1	201.6
	220° F	2.1	6.1	17.6	28.5	8.9	25.3	38.8	51.0	83.5	129.1	218.5
110° F	140° F	1.9	5.5	15.9	25.7	8.0	22.8	35.0	46.1	75.3	116.3	196.9
	180° F	2.1	6.1	17.6	28.5	8.9	25.3	38.8	51.1	83.5	129.0	218.4
	220° F	2.3	6.7	19.3	31.1	9.7	27.6	42.4	55.8	91.2	141.0	238.6
120° F	140° F	2.0	5.8	16.7	27.0	8.4	24.0	36.8	48.5	79.2	122.3	207.1
	180° F	2.2	6.5	18.8	30.5	9.5	27.0	41.5	54.6	89.3	137.9	233.5
	220° F	2.4	7.2	20.8	33.6	10.5	29.8	45.8	60.3	98.5	152.2	257.7

Hot Gas Bypass Capacities in Kilowatts

R404A

Cond Temp'	Discharge Temp	A9 9 mm	A9 15 mm	A9 22 mm	A9 28 mm	A8AOE 9 mm	A8AOE 15 mm	A8AOE 22 mm	A81OE 28 mm	A81OE 35 mm	A82OE 42 mm	A82OE 54 mm
30° C	60° C	5.2	15.3	44.3	71.0	22.3	63.4	95.7	124.7	208.3	319.3	545.3
	80° C	5.5	16.4	47.5	76.0	23.9	68.0	102.5	133.6	223.2	342.1	584.2
	100° C	5.9	17.5	50.6	81.1	25.5	72.5	109.3	142.5	238.1	364.8	623.1
40° C	60° C	5.9	17.5	50.6	81.8	25.5	72.6	111.3	146.6	239.5	370.1	626.6
	80° C	6.4	19.0	55.0	88.9	27.7	78.9	121.0	159.4	260.5	402.5	681.4
	100° C	6.9	20.5	59.3	96.0	29.9	85.1	130.6	171.9	281.0	434.3	735.1
45° C	60° C	6.2	18.3	52.9	85.6	26.7	76.0	116.5	153.5	250.7	387.4	655.9
	80° C	6.8	20.1	58.2	94.1	29.3	83.5	128.1	168.8	275.7	426.1	721.2
	100° C	7.4	21.9	63.3	102.4	31.9	90.9	139.3	183.6	299.9	463.4	784.4
50° C	60° C	6.4	18.8	54.3	87.9	27.4	78.0	119.5	157.5	257.3	397.6	673.1
	80° C	7.1	21.0	60.7	98.2	30.6	87.1	133.6	176.1	287.6	444.4	752.4
	100° C	7.8	23.1	66.8	108.0	33.6	95.8	146.9	193.6	316.2	488.6	827.1

Hot Gas Bypass Capacities in Kilowatts

R507

Cond. Temp.	Discharge Temp	A9 9 mm	A9 15 mm	A9 22 mm	A9 28 mm	A8AOE 9 mm	A8AOE 15 mm	A8AOE 22 mm	A81OE 28 mm	A81OE 35 mm	A82OE 42 mm	A82OE 54 mm
30° C	60° C	5.4	16.0	46.4	74.3	23.4	66.4	100.1	130.5	218.0	334.1	570.7
	80° C	5.8	17.3	49.9	79.9	25.1	71.4	107.7	140.3	234.4	359.2	613.6
	100° C	6.2	18.4	53.3	85.3	26.9	76.3	115.0	149.8	250.4	383.7	655.5
40° C	60° C	6.3	18.6	53.7	86.8	27.1	77.1	118.2	155.6	254.3	393.0	665.3
	80° C	6.9	20.3	58.6	94.8	29.5	84.1	129.0	169.8	277.6	428.9	726.1
	100° C	7.4	21.9	63.3	102.3	31.9	90.8	139.3	183.4	299.7	463.1	784.0
45° C	60° C	6.6	19.7	56.9	91.9	28.7	81.6	125.1	164.8	269.3	416.1	704.4
	80° C	7.3	21.7	62.7	101.4	31.6	90.0	138.0	181.8	297.0	458.9	776.9
	100° C	8.0	23.6	68.2	110.3	34.4	97.9	150.1	197.7	323.0	499.1	844.9
50° C	60° C	6.9	20.5	59.2	95.8	29.8	85.0	130.3	171.7	280.4	433.4	733.6
	80° C	7.7	22.9	66.3	107.2	33.4	95.1	145.9	192.2	313.9	485.1	821.2
	100° C	8.5	25.2	72.8	117.7	36.7	104.4	160.1	211.0	344.6	532.5	901.5

Discharge Regulators for Supermarket Applications

The Parker Refrigerating Specialties Division has built a reputation as a principal supplier of reliable, high side control valves to the supermarket industry. One of the more critical applications on a commercial refrigeration system where hot gas is utilized for defrosting purposes is the use of a regulator in the discharge line. Refrigerating Specialties types A81BL or A82BL have become a standard for many supermarket rack manufacturers specifically for this application.

The "BL" version of an A8 regulator in a discharge application serves two functions. The valve is either in a wide open (or bypassed) position with it's solenoid energized to facilitate a minimum pressure drop through the valve when no refrigeration circuits are calling for defrost. In this mode, the valve essentially is acting as a low pressure drop solenoid in an opened position. When a refrigeration circuit begins a defrost sequence however, the solenoid on the discharge A8_BL regulator is de-energized (via the defrost program), thereby converting the valve into a differential pressure regulator.

A differential regulator communicates outlet pressure into the valve's bonnet in order to compensate range spring pressure with downstream pressure. The set point of the valve thus becomes the sum of spring pressure plus outlet pressure. Whatever the range spring pressure is set for effectively becomes the

pressure difference the valve will maintain from its inlet to outlet. If, for example, the regulator was set to maintain a 25 psi set point, the valve will regulate and maintain an upstream pressure 25 psi higher than it's downstream pressure, regardless of fluctuations in downstream pressure. In this application, the regulator ensures that the hot gas pressure supplied to a circuit for defrost purposes will be high enough to overcome the pressure drop through the supply line, the losses through valves and fittings, and through the evaporator coil. The defrost condensate exits the evaporator and is then introduced, at an elevated pressure, back into the liquid line.

Because each system may vary due to any number of design considerations, the A81BL and A82BL regulators are field adjustable. The regulator can therefore be adjusted to determine the most efficient set point while ensuring that each evaporator defrosts in a timely and thorough manner.

For larger systems that exceed the capacity of the A8 regulator line, Refrigerating Specialties offers a higher capacity flanged valve for discharge applications, the A4AB or A4ABL.

For sizing, please see "Discharge Capacities" on pages 22 and 23.

Figure 5 - Discharge regulator for supermarket applications. (See page 72 for symbols legend.)

Valve Legend				
Label	Valve Function	Application	Design	Selection Page
A	Inlet Pressure Regulator	Discharge Pressure	A8	32-39
B	Solenoid Valve	Liquid Feed	SC	65

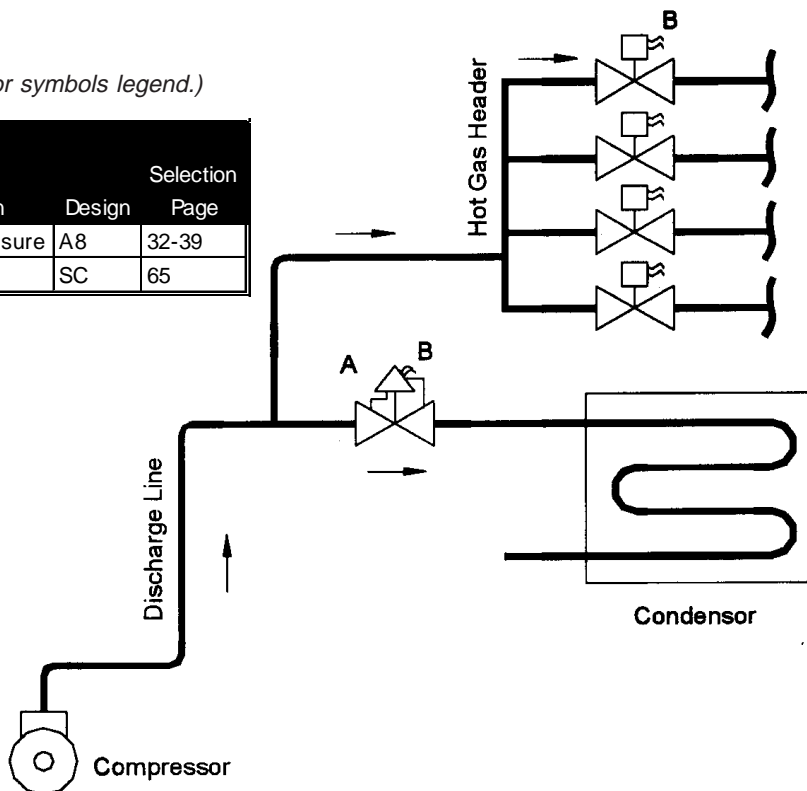

Crankcase Pressure Regulators

Crankcase pressure regulators, also known as “CPRs” or “holdback” regulators, are outlet pressure regulators installed in the suction line which prevent an excessive downstream pressure regardless of fluctuations in load or inlet conditions. R/S types A8AOE, A810E, and A82OE comprise the line of commercial outlet pressure regulators that can be applied as crankcase pressure regulators.

When system conditions occur that allow suction pressures to increase appreciably above normal operating levels, a crankcase regulator should be applied. Without a downstream regulator, which effectively throttles down the suction pressure to the compressor, a compressor motor overload condition can occur. Such conditions are likely during pull down

after a hot gas defrost period, or during system start-up. An A8-OE outlet regulator will gradually close when the downstream pressure begins to rise above the valve’s set point, and will gradually open when the outlet pressure falls below its set point, effectively preventing the compressor suction pressure from exceeding the regulator’s set point.

No crankcase regulator can maintain its set for pressure if branch lines feed into the main suction line downstream of the regulator. For that reason, it is important that no lines feed into the suction line between the regulator and the compressor.

(For sizing, please reference suction capacity charts for A8 regulators on pages 8 through 15.)

Figure 6 - Crankcase pressure regulator application. (See page 72 for symbol legend)

Valve Legend				
Label	Valve Function	Application	Design	Selection Page
A	Outlet Pressure Regulator	Crankcase Pressure	A8_OE	8-15
B	Solenoid Valve	Liquid Feed	SC	65

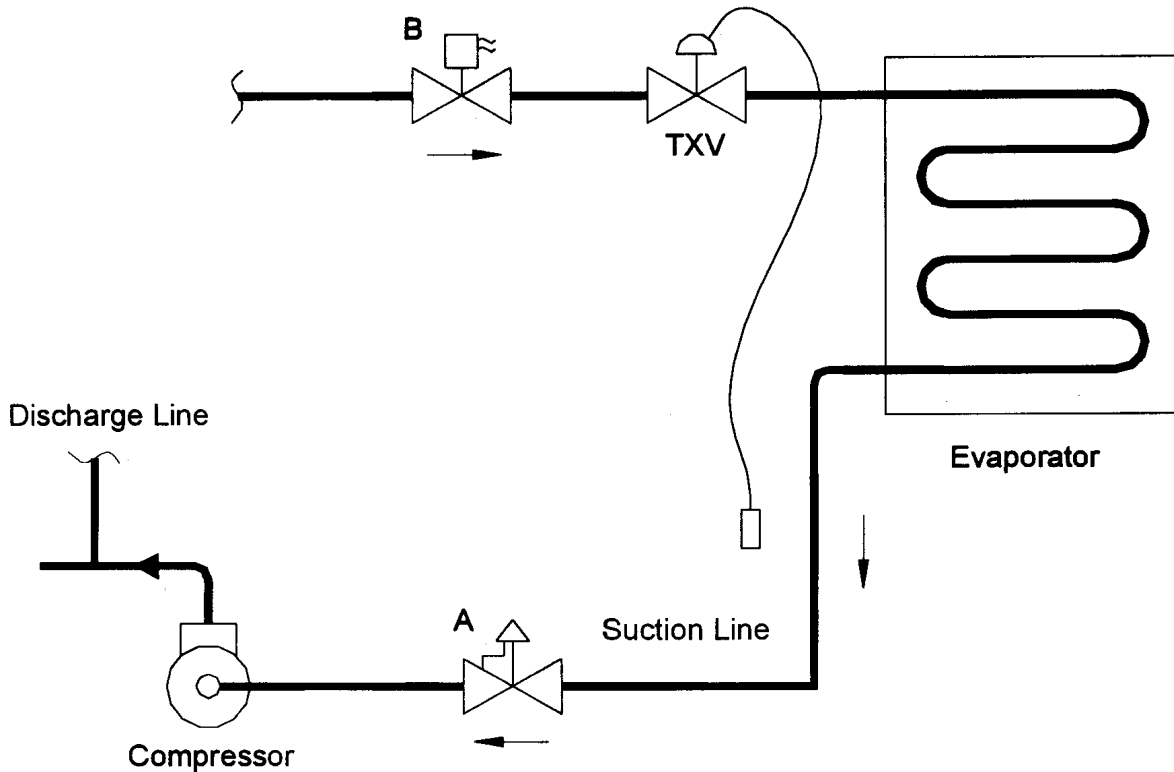

SC Suction Solenoid Valves

Features

- Highest capacity non-flanged valve in the industry.
- Available with 208V/240V/60Hz wide range voltage coil.
- Low pressure drop, internally pilot operated.
- All stainless steel bolts, stem, piston and plug.
- Manual opening stem.
- Sweat in place without disassembly.
- Molded class "F" coil construction.
- DIN coil assemblies available.
- Interchangeable capacity cartridges. Same as those used on (S)PORT EPRs.



Specifications

- Design pressure (M.R.P.): 450 psig (31.0 bar).
- Maximum opening pressure differential (MOPD): 300 psig (20.7 bar). (Except 208/240V/60Hz wide voltage range coil).
- Minimal fluid temperature: -40° F (-40° C).
- UL listed (except 50Hz), file SA5473.
- CSA certified, file LR20991-14.

Standard Voltages

- 120V/60Hz, 110V/50Hz
- 208V/240V/60Hz, 220V/50Hz
- 240V/50Hz
- 240V/60Hz, 220V/50Hz (DIN)
- 240V/50Hz (DIN)

Valve Nomenclature

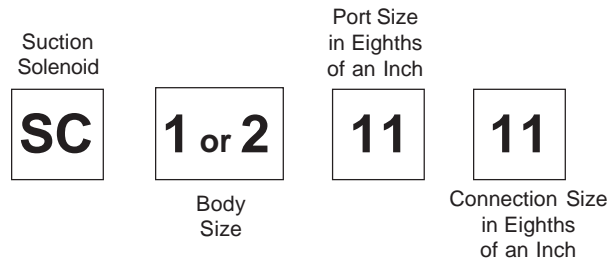

SC Port/Connection Size Combinations*

Type	Port Size	Connection Sizes Available
SC1	03 (3/8", 9mm)	07, 09, 11,13, 17 (7/8"/22mm, 1-1/8"/28mm, 1-3/8"/35mm, 1-5-8"/42mm, 2-1/8"/54mm)
	05 (5/8" 15mm)	07, 09, 11,13, 17 (7/8"/22mm, 1-1/8"/28mm, 1-3/8"/35mm, 1-5-8"/42mm, 2-1/8"/54mm)
	07 (7/8", 22mm)	07, 09, 11,13, 17 (7/8"/22mm, 1-1/8"/28mm, 1-3/8"/35mm, 1-5-8"/42mm, 2-1/8"/54mm)
	09 (1-1/8", 28mm)	07, 09, 11,13, 17 (7/8"/22mm, 1-1/8"/28mm, 1-3/8"/35mm, 1-5-8"/42mm, 2-1/8"/54mm)
SC-II	11 (1-3/8", 35mm)	09, 11,13, 17 (1-1/8"/28mm, 1-3/8"/35mm, 1-5-8"/42mm, 2-1/8"/54mm)
SC2	13 (1-5/8", 42mm)	13, 17, 21 (1-5/8" /42mm, 2-1/8" /54mm, 2-5/8" /66mm)
	17 (2-1/8", 54mm)	17, 21 (2-1/8" /54mm, 2-5/8" /66mm)
	21 (2-5/8", 66mm)	21 (2-5/8", 66mm)

**(NOTE: Completely corrosion resistant SC-II solenoids with aluminum bronze bodies and cartridge assemblies have same port/connection combinations as standard SC solenoids, but are not available in the 13, 17, or 21 port size versions).*

Description: The SC series of commercial solenoids was developed as a flexible, low pressure drop, suction line solenoid valve, in a wide range of port and connection sizes. With cartridge (port) sizes available up to 2-5/8" (66mm) in size, SC solenoids offer the greatest capacity of any non-flanged commercial solenoid in the industry. The unique design of the SC solenoid is a mirror image of the (S)PORT regulator line, utilizing the same cartridges, solenoid coil assemblies, bodies, and

internal parts as those used in the construction of the (S)PORT regulators. With this flexible line of suction line solenoids complementing the complete line of (S)PORT regulators, a wide range of high capacity, suction line refrigeration control valves are now available from a single source.

Along with (S)PORT regulators, SC solenoids are manufactured with ductile iron bodied valves with brazed

copper couplings, and are suitable for most common commercial refrigerants along with certain oils. The SC solenoid may be opened by means of a manual opening stem for servicing or in case of an electrical power failure.

The SC-II series of valves are manufactured with completely corrosion resistant materials including aluminum bronze bodies and cartridge assemblies, and stainless steel adapter bolts. Cartridges, and solenoids are interchangeable with the (S)PORT-II regulator line.

Variations: SC1/ SC-II Solenoids: Five port sizes, from 3/8" (9mm) through 1-3/8" (35mm). SC2 Solenoid: three port sizes, from 1-5/8" (42mm) through 2-5/8" (66mm).

Installation: SC solenoid valves can be mounted either in a vertical or horizontal line with the refrigerant flow in the direction of the arrow on the body. These valves may be soldered into the line without disassembly. When brazing in line, typically a wet cloth wrapped around the valve body is recommended to dissipate heat. **If a valve is disassembled prior to installation, always have the correct gasket/ O-ring kit available**

for reassembly. The internal cartridge-to-body O-ring will need to be replaced prior to reassembly.

Electrical: SC commercial solenoid valves utilize a molded water resistant Class "F" solenoid coil with an open frame coil housing that meets NEMA 3R and 4 requirements. A class "H" DIN coil is also available with certain voltages. Power consumption during normal operation will be 10.2 watts or less.

All coils except for the 208/240V/60Hz version operate with a 300 psi (20.7 bar) maximum opening pressure differential (MOPD). The 208/240V/60Hz coil operates with a 280 psi (19.3 bar) MOPD.

All coils are designed to operate with a line voltage from 85% to 110% of rated coil voltage. Operating with a line voltage above or below these limits may result in coil burn out.

Ordering Guide: Specify valve type (SC1, SC-II or SC2), port and connection size, coil voltage, and frequency.

NOTE: For SC valve suction capacity tables, please reference pages 8-15 of this catalog.

SC1 / SC2 Liquid Capacities in Evaporator Tons

Based on 100° F Condensing, 40° F Evaporator and no flashing through the valve for the pressure drop listed.

Port Size	R22 2 psi pr drop	R22 4 psi pr drop	R134a 2 psi pr drop	R134a 4 psi pr drop	R404A 2 psi pr drop	R404A 4 psi pr drop	R507 2 psi pr drop	R507 4 psi pr drop
03 (3/8")	6	9	6	9	4	6	4	6
05 (5/8")	14	20	13	19	9	12	9	13
07 (7/8")	22	31	21	29	14	19	14	20
09 (1-1/8")	35	50	33	47	22	31	23	32
11 (1-3/8")	49	69	46	65	30	43	32	45
13 (1-5/8")	78	110	73	104	48	68	50	71
17 (2-1/8")	117	165	110	156	72	102	76	107
21 (2-5/8")	156	220	147	207	96	136	101	143

SC1 / SC2 Liquid Capacities in Evaporator Kilowatts

Based on 37.7° C Condensing, 4.4° C Evaporator and no flashing through the valve for the pressure drop listed.

Port Size	R22 0.14 bar pr drop	R22 0.27 bar pr drop	R134a 0.14 bar pr drop	R134a 0.27 bar pr drop	R404A 0.14 bar pr drop	R404A 0.27 bar pr drop	R507 0.14 bar pr drop	R507 0.27 bar pr drop
03 (9mm)	23	32	21	30	14	20	15	21
05 (15mm)	50	71	47	67	31	44	32	46
07 (22mm)	78	110	73	103	48	68	50	71
09 (28mm)	123	174	116	164	76	107	80	113
11 (35mm)	172	243	162	229	106	150	111	157
13 (42mm)	274	387	258	365	169	239	177	251
17 (54mm)	411	581	387	547	253	358	266	376
21 (66mm)	548	775	516	729	338	477	354	501

S81 / S82 Solenoid Valves

Features

- Highest capacity non-flanged solenoid valve in the industry.
- Low pressure drop.
- Manual opening stem.
- Sweat in place without disassembly.
- Molded class "H" coil construction.
- DIN coil assemblies available.
- Inlet pressure access fitting.
- Interchangeable capacity cartridges.



Specifications

- Maximum opening pressure differential (MOPD): 300 psig (20.7 bar).
- Minimum fluid temperature: -40° F (-40° C).
- Design pressure (M.R.P.): 450 psig (31.0 bar).
- UL listed, file SA5473.
- CSA certified, file LR20991-14.

Standard Voltages

- 120V/60Hz, 110V/50Hz
- 240V/60Hz, 220V/50Hz
- 208V/60Hz
- 240V/60Hz, 220V/50Hz (DIN)
- 240V/50Hz (DIN)

Valve Nomenclature

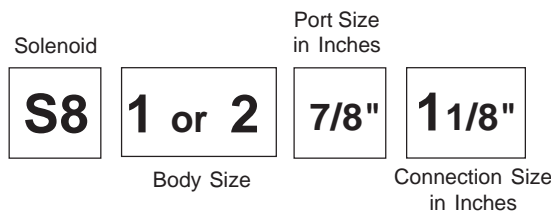

S8 Port/Connection Size Combinations

Valve Type	Port Size	Available Connection Sizes
S81	3/8" (9mm)	7/8", 1-1/8", 1-3/8" (22mm, 28mm, 35mm)
S81	5/8" (15mm)	7/8", 1-1/8", 1-3/8" (22mm, 28mm, 35mm)
S81	7/8" (22mm)	7/8", 1-1/8", 1-3/8" (22mm, 28mm, 35mm)
S81	1-1/8" (28mm)	1-1/8", 1-3/8", 1-5/8" (28mm, 35mm, 42mm)
S81	1-3/8" (35mm)	1-3/8", 1-5/8", 2-1/8" (35mm, 42mm, 54mm)
S82	1-5/8" (42mm)	1-5/8", 2-1/8", 2-5/8" (42mm, 54mm, 66mm)
S82	2-1/8" (54mm)	2-1/8", 2-5/8" (54mm, 66mm)
S82	2-5/8" (66mm)	2-5/8" (66mm)

Description: The S8 series of commercial solenoids was developed as a versatile, general purpose, commercial refrigeration valve, capable of being applied in most liquid, hot gas, or suction applications. With cartridge (port) sizes available up to 2-5/8" (66mm) in size, S8 solenoids offer the greatest capacity of any non-flanged commercial solenoid in the industry. The unique design of the S8 solenoid is a mirror image of

the A8 regulator line, utilizing the same cartridges, solenoid coil assemblies, bodies, and internal parts as those used in the construction of the A8's. With this flexible line of commercial solenoids complementing the complete line of commercial A8 regulators, a wide offering of high capacity commercial refrigeration control valves are now available from a single source.

Similar to the A8 regulators, S8 solenoids are manufactured with ductile iron bodies with brazed copper couplings, and are suitable for most common commercial refrigerants along with certain oils. The S8 solenoid may be opened by means of a manual opening stem for servicing or in case of an electrical power failure.

Variations: S81 Solenoid: Five port sizes, from 3/8" (9mm) through 1-3/8". S82 Solenoid: Three port sizes, from 1-5/8" through 2-5/8".

Installation: S8 solenoid valves can be mounted either in a vertical or horizontal line with the refrigerant flow in the direction of the arrow on the body. These valves may be soldered into the line without disassembly. A wet cloth should be wrapped around the valve and the soldering flame should be directed away from the valve body.

If a valve is disassembled prior to installation, always have the correct gasket/O-ring kit available for reassembly. The internal cartridge-to-body O-ring will need to be replaced prior to reassembly.

Electrical: S8 commercial solenoid valves utilize a molded water resistant Class "H" solenoid coil with a general purpose coil housing which meets NEMA 3R and 4 requirements. A class "H" DIN coil is also available with certain voltages. Power consumption during normal operation will be 10.2 watts or less. The coils are designed to operate with a line voltage from 85% to 110% of rated coil voltage. Operating with a line voltage above or below these limits may result in coil burn out.

Ordering Guide: Specify valve type (S81 or S82), port and connection size, and coil voltage and frequency.

NOTE: For S81 / S82 valve suction capacity tables, please reference pages 8-15 of this catalog.

S81 / S82 Liquid Capacities in Evaporator Tons

Based on 100° F Condensing, 40° F Evaporator and no flashing through the valve for the pressure drop listed.

Port Size	R22 2 psi pr drop	R22 4 psi pr drop	R134a 2 psi pr drop	R134a 4 psi pr drop	R404a 2 psi pr drop	R404a 4 psi pr drop	R507 2 psi pr drop	R507 4 psi pr drop
3/8"	6	9	6	9	4	6	4	6
5/8"	14	20	13	19	9	12	9	13
7/8"	22	31	21	29	14	19	14	20
1-1/8"	35	50	33	47	22	31	23	32
1-3/8"	49	69	46	65	30	43	32	45
1-5/8"	78	110	73	104	48	68	50	71
2-1/8"	117	165	110	156	72	102	76	107
2-5/8"	156	220	147	207	96	136	101	143

S81 / S82 Liquid Capacities in Evaporator Kilowatts

Based on 37.7° C Condensing, 4.4° C Evaporator and no flashing through the valve for the pressure drop listed.

Port Size	R22 0.14 bar pr drop	R22 0.27 bar pr drop	R134a 0.14 bar pr drop	R134a 0.27 bar pr drop	R404a 0.14 bar pr drop	R404a 0.27 bar pr drop	R507 0.14 bar pr drop	R507 0.27 bar pr drop
9mm	23	32	21	30	14	20	15	21
15mm	50	71	47	67	31	44	32	46
22mm	78	110	73	103	48	68	50	71
28mm	123	174	116	164	76	107	80	113
35mm	172	243	162	229	106	150	111	157
42mm	274	387	258	365	169	239	177	251
54mm	411	581	387	547	253	358	266	376
66mm	548	775	516	729	338	477	354	501

Temperature Pressure Chart - PSIG

Temp		MP 39 R-401A		HP 80 R-402A		HP 62 R-404A	FX 10 R-408A	FX 56 R-409A		AZ 20 R-410A
°F	°C	Liquid	Vapor	Liquid	Vapor	Liquid	Liquid	Liquid	Vapor	
-50	-45.6	-	-	-	-	0.6	1.6	12.4	17.2	5.0
-45	-42.8	-	-	-	-	2.7	1.1	9.7	15.2	7.0
-40	-40.0	8.1	13.2	6.8	6.3	5.0	3.3	6.8	13.1	11.6
-35	-37.2	5.1	10.7	9.6	9.1	7.6	5.6	3.5	10.7	14.9
-30	-34.4	1.7	7.9	12.6	12.1	10.4	8.2	0.0	8.1	18.5
-25	-31.7	1.0	4.8	16.0	15.4	13.4	11.0	2.0	5.1	22.5
-20	-28.9	3.0	1.4	19.6	18.9	16.8	14.1	4.1	1.9	26.9
-15	-26.1	5.2	1.2	23.6	22.9	20.5	17.5	6.5	0.8	31.6
-10	-23.3	7.7	3.3	27.9	27.1	24.5	21.2	9.0	2.8	36.8
-5	-20.6	10.3	5.5	32.6	31.7	28.8	25.2	11.8	4.9	42.5
0	-17.8	13.2	8.0	37.6	36.7	33.5	29.5	14.8	7.2	48.6
5	-15.0	16.3	10.7	43.1	42.1	38.6	34.2	18.1	9.7	55.2
10	-12.2	19.7	13.7	49.0	48.0	44.0	39.3	21.7	12.5	62.3
15	-9.4	23.4	16.9	55.3	54.2	49.9	44.8	25.5	15.4	70.0
20	-6.7	27.4	20.4	62.1	60.9	56.2	50.7	29.6	18.7	78.3
25	-3.9	31.7	24.2	69.3	68.1	63.0	57.0	34.0	22.2	87.2
30	-1.1	36.4	28.3	77.1	75.8	70.3	63.7	38.7	26.0	96.8
35	1.7	41.3	32.8	85.4	84.0	78.1	71.0	43.8	30.1	107.0
40	4.4	46.6	37.6	94.2	92.8	86.4	78.7	49.2	34.5	118.0
45	7.2	52.4	42.7	104.0	102.0	95.2	87.0	54.9	39.2	130.0
50	10.0	58.5	48.2	114.0	112.0	104.7	95.8	61.0	44.3	142.0
55	12.8	65.0	54.1	124.0	123.0	114.7	105.1	67.6	49.8	156.0
60	15.6	71.9	60.4	136.0	134.0	125.3	115.1	74.5	55.6	170.0
65	18.3	79.3	67.2	147.0	146.0	136.6	125.6	81.8	61.9	185.0
70	21.1	87.1	74.4	160.0	158.0	148.6	136.8	89.5	68.6	201.0
75	23.9	95.4	82.1	173.0	171.0	161.2	148.7	97.7	75.8	217.0
80	26.7	104.0	90.2	187.0	185.0	174.6	161.2	106.4	83.4	235.0
85	29.4	114.0	98.9	202.0	200.0	188.8	174.4	115.5	91.5	254.0
90	32.2	123.0	108.0	218.0	215.0	203.7	188.4	125.2	100.2	274.0
95	35.0	134.0	118.0	233.0	232.0	219.4	203.1	135.3	109.4	295.0
100	37.8	145.0	128.0	251.0	249.0	235.9	218.7	146.0	119.2	317.0
105	40.6	156.0	139.0	269.0	267.0	253.4	235.0	157.2	129.6	341.0
110	43.3	169.0	151.0	288.0	286.0	271.7	252.1	169.0	140.6	365.0
115	46.1	181.0	163.0	308.0	305.0	290.9	270.2	181.4	152.3	391.0
120	48.9	195.0	176.0	328.0	326.0	311.1	289.1	194.4	164.7	418.0
125	51.7	209.0	189.0	350.0	347.0	332.3	308.9	208.0	177.8	446.0
130	54.4	224.0	203.0	372.0	370.0	354.5	329.7	222.3	191.6	476.0
135	57.2	239.0	218.0	396.0	393.0	377.8	351.5	237.2	206.3	507.0
140	60.0	255.0	234.0	420.0	418.0	402.2	374.3	252.9	221.8	539.0
145	62.8	272.0	250.0	446.0	443.0	427.7	398.1	269.3	238.2	573.0
150	65.6	299.0	267.0	472.0	470.0	454.4	423.0	293.0	286.4	608.0

Pressures shown in psig

Italics = inches Hg. Below 1 ATM

Temperature Pressure Chart - PSIG

Temp		R-12	R-22	R-123	R-134a	R-502	AZ-50 R-507
°F	°C						
-50	-45.6	<i>15.4</i>	<i>6.2</i>	<i>29.2</i>	<i>18.4</i>	<i>0.2</i>	1.0
-45	-42.8	<i>13.3</i>	<i>2.7</i>	<i>29.0</i>	<i>16.6</i>	1.9	3.0
-40	-40.0	<i>11.0</i>	0.5	<i>28.9</i>	<i>14.7</i>	4.1	5.5
-35	-37.2	<i>8.4</i>	2.6	<i>28.7</i>	<i>12.3</i>	6.5	8.2
-30	-34.4	<i>5.5</i>	4.9	<i>28.4</i>	<i>9.7</i>	9.2	11.1
-25	-31.7	<i>2.3</i>	7.4	<i>28.1</i>	<i>6.8</i>	12.1	14.3
-20	-28.9	0.6	10.1	<i>27.8</i>	<i>3.6</i>	15.3	17.8
-15	-26.1	2.4	13.2	<i>27.4</i>	<i>0.1</i>	18.8	21.7
-10	-23.3	4.5	16.4	27.0	2.0	22.6	25.8
-5	-20.6	6.7	20.0	26.5	4.1	26.6	30.3
0	-17.8	9.1	24.0	25.9	6.5	31.1	35.2
5	-15.0	11.8	28.2	25.3	9.1	35.9	40.5
10	-12.2	14.6	32.7	24.6	11.9	41.0	46.1
15	-9.4	17.7	37.7	23.7	15.1	46.5	52.2
20	-6.7	21.0	43.0	22.8	18.4	52.5	58.8
25	-3.9	24.6	48.7	21.8	22.1	58.8	65.8
30	-1.1	28.4	54.9	20.7	26.1	65.6	73.3
35	1.7	32.5	61.4	19.5	30.4	72.8	81.3
40	4.4	36.9	68.5	18.1	35.1	80.5	89.8
45	7.2	41.6	76.0	16.6	40.0	88.7	98.9
50	10.0	46.7	84.0	15.0	45.4	97.4	109.0
55	12.8	52.0	92.5	13.1	51.2	107.0	119.0
60	15.6	57.7	101.6	11.2	57.4	116.4	130.0
65	18.3	63.7	111.0	9.0	64.0	127.0	141.0
70	21.1	70.1	121.4	6.6	71.1	138.0	154.0
75	23.9	76.9	132.0	4.0	78.6	149.0	167.0
80	26.7	84.1	144.0	1.2	86.7	161.0	180.0
85	29.4	91.7	156.0	0.9	95.1	174.0	195.0
90	32.2	99.7	168.4	2.5	104.2	187.4	210.0
95	35.0	108.0	182.0	4.2	113.8	201.0	226.0
100	37.8	117.0	196.0	6.1	124.1	216.2	244.0
105	40.6	127.0	211.0	8.1	134.9	232.0	252.0
110	43.3	136.0	226.4	10.3	146.3	247.9	281.0
115	46.1	147.0	243.0	12.6	158.4	265.0	301.0
120	48.9	158.0	260.0	15.1	171.1	282.7	322.0
125	51.7	169.0	278.4	17.7	184.5	301.0	344.0
130	54.4	181.0	296.8	20.6	198.7	320.8	368.0
135	57.2	193.0	317.0	23.6	213.6	341.0	393.0
140	60.0	207.0	337.3	26.8	229.3	362.6	419.0
145	62.8	220.0	359.0	30.2	245.7	385.0	446.0
150	65.6	235.0	381.0	33.8	263.0	408.4	475.0

Black figures = psig

Italics = inches Hg. Below 1 ATM

Temperature Pressure Chart - Bar

Temp		MP 39 R-401A		HP 80 R-402A		HP 62 R-404A	FX 10 R-408A	FX 56 R-409A		AZ 20 R-410A
°F	°C	Liquid	Vapor	Liquid	Vapor	Liquid	Liquid	Liquid	Vapor	
-50	-45.6	-	-	-	-	0.0	0.1	0.9	1.2	0.3
-45	-42.8	-	-	-	-	0.2	0.1	0.7	1.0	0.5
-40	-40.0	205.7	335.3	0.5	0.4	0.3	0.2	0.5	0.9	0.8
-35	-37.2	129.5	271.8	0.7	0.6	0.5	0.4	0.2	0.7	1.0
-30	-34.4	43.2	200.7	0.9	0.8	0.7	0.6	0.0	0.6	1.3
-25	-31.7	0.1	121.9	1.1	1.1	0.9	0.8	0.1	0.4	1.6
-20	-28.9	0.2	35.6	1.4	1.3	1.2	1.0	0.3	0.1	1.9
-15	-26.1	0.4	0.1	1.6	1.6	1.4	1.2	0.4	0.1	2.2
-10	-23.3	0.5	0.2	1.9	1.9	1.7	1.5	0.6	0.2	2.5
-5	-20.6	0.7	0.4	2.2	2.2	2.0	1.7	0.8	0.3	2.9
0	-17.8	0.9	0.6	2.6	2.5	2.3	2.0	1.0	0.5	3.4
5	-15.0	1.1	0.7	3.0	2.9	2.7	2.4	1.2	0.7	3.8
10	-12.2	1.4	0.9	3.4	3.3	3.0	2.7	1.5	0.9	4.3
15	-9.4	1.6	1.2	3.8	3.7	3.4	3.1	1.8	1.1	4.8
20	-6.7	1.9	1.4	4.3	4.2	3.9	3.5	2.0	1.3	5.4
25	-3.9	2.2	1.7	4.8	4.7	4.3	3.9	2.3	1.5	6.0
30	-1.1	2.5	2.0	5.3	5.2	4.8	4.4	2.7	1.8	6.7
35	1.7	2.8	2.3	5.9	5.8	5.4	4.9	3.0	2.1	7.4
40	4.4	3.2	2.6	6.5	6.4	6.0	5.4	3.4	2.4	8.1
45	7.2	3.6	2.9	7.2	7.0	6.6	6.0	3.8	2.7	9.0
50	10.0	4.0	3.3	7.9	7.7	7.2	6.6	4.2	3.1	9.8
55	12.8	4.5	3.7	8.6	8.5	7.9	7.2	4.7	3.4	10.8
60	15.6	5.0	4.2	9.4	9.2	8.6	7.9	5.1	3.8	11.7
65	18.3	5.5	4.6	10.1	10.1	9.4	8.7	5.6	4.3	12.8
70	21.1	6.0	5.1	11.0	10.9	10.2	9.4	6.2	4.7	13.9
75	23.9	6.6	5.7	11.9	11.8	11.1	10.3	6.7	5.2	15.0
80	26.7	7.2	6.2	12.9	12.8	12.0	11.1	7.3	5.8	16.2
85	29.4	7.9	6.8	13.9	13.8	13.0	12.0	8.0	6.3	17.5
90	32.2	8.5	7.4	15.0	14.8	14.0	13.0	8.6	6.9	18.9
95	35.0	9.2	8.1	16.1	16.0	15.1	14.0	9.3	7.5	20.3
100	37.8	10.0	8.8	17.3	17.2	16.3	15.1	10.1	8.2	21.9
105	40.6	10.8	9.6	18.6	18.4	17.5	16.2	10.8	8.9	23.5
110	43.3	11.7	10.4	19.9	19.7	18.7	17.4	11.7	9.7	25.2
115	46.1	12.5	11.2	21.2	21.0	20.1	18.6	12.5	10.5	27.0
120	48.9	13.4	12.1	22.5	22.5	21.5	19.9	13.4	11.4	28.8
125	51.7	14.4	13.0	24.1	23.9	22.9	21.3	14.3	12.3	30.8
130	54.4	15.4	14.0	25.7	25.5	24.4	22.7	15.3	13.2	32.8
135	57.2	16.5	15.0	27.3	27.1	26.1	24.2	16.4	14.2	35.0
140	60.0	17.6	16.1	29.0	28.8	27.7	25.8	17.4	15.3	37.2
145	62.8	18.8	17.2	30.8	30.6	29.5	27.5	18.6	16.4	39.5
150	65.6	20.6	18.4	32.6	32.4	31.3	29.2	20.2	19.8	41.9

Temperature Pressure Chart - Bar

Temp		R-12	R-22	R-123	R-134a	R-502	AZ-50 R-507
°F	°C						
-50	-45.6	391.2	157.5	741.7	467.4	5.1	0.1
-45	-42.8	337.8	68.6	736.6	421.6	0.1	0.2
-40	-40.0	279.4	0.0	734.1	373.4	0.3	0.4
-35	-37.2	213.4	0.2	729.0	312.4	0.4	0.6
-30	-34.4	139.7	0.3	721.4	246.4	0.6	0.8
-25	-31.7	58.7	0.5	713.7	172.7	0.8	1.0
-20	-28.9	0.0	0.7	706.1	91.4	1.1	1.2
-15	-26.1	0.2	0.9	696.0	2.5	1.3	1.5
-10	-23.3	0.3	1.1	1.9	0.1	1.6	1.8
-5	-20.6	0.5	1.4	1.8	0.3	1.8	2.1
0	-17.8	0.6	1.7	1.8	0.4	2.1	2.4
5	-15.0	0.8	1.9	1.7	0.6	2.5	2.8
10	-12.2	1.0	2.3	1.7	0.8	2.8	3.2
15	-9.4	1.2	2.6	1.6	1.0	3.2	3.6
20	-6.7	1.4	3.0	1.6	1.3	3.6	4.1
25	-3.9	1.7	3.4	1.5	1.5	4.1	4.5
30	-1.1	2.0	3.8	1.4	1.8	4.5	5.1
35	1.7	2.2	4.2	1.3	2.1	5.0	5.6
40	4.4	2.5	4.7	1.2	2.4	5.6	6.2
45	7.2	2.9	5.2	1.1	2.8	6.1	6.8
50	10.0	3.2	5.8	1.0	3.1	6.7	7.5
55	12.8	3.6	6.4	0.9	3.5	7.4	8.2
60	15.6	4.0	7.0	0.8	4.0	8.0	9.0
65	18.3	4.4	7.7	0.6	4.4	8.8	9.7
70	21.1	4.8	8.4	0.5	4.9	9.5	10.6
75	23.9	5.3	9.1	0.3	5.4	10.3	11.5
80	26.7	5.8	9.9	0.1	6.0	11.1	12.4
85	29.4	6.3	10.8	0.1	6.6	12.0	13.4
90	32.2	6.9	11.6	0.2	7.2	12.9	14.5
95	35.0	7.4	12.6	0.3	7.8	13.9	15.6
100	37.8	8.1	13.5	0.4	8.6	14.9	16.8
105	40.6	8.8	14.6	0.6	9.3	16.0	17.4
110	43.3	9.4	15.6	0.7	10.1	17.1	19.4
115	46.1	10.1	16.8	0.9	10.9	18.3	20.8
120	48.9	10.9	17.9	1.0	11.8	19.5	22.2
125	51.7	11.7	19.2	1.2	12.7	20.8	23.7
130	54.4	12.5	20.5	1.4	13.7	22.1	25.4
135	57.2	13.3	21.9	1.6	14.7	23.5	27.1
140	60.0	14.3	23.3	1.8	15.8	25.0	28.9
145	62.8	15.2	24.8	2.1	16.9	26.6	30.8
150	65.6	16.2	26.3	2.3	18.1	28.2	32.8

Black figures = bar

Italics = millimeters Hg. Below 1 ATM

Abbreviations and Terminology









Abbreviations

A (Amp)	Ampere
BTU/hr	British Thermal Units per Hour
BTU/min.	British Thermal Units per Minute
°C	Degrees Celsius or Centigrade
cm ² (sq. cm)	Square centimeters
CPR	Crankcase Pressure Regulator
CSA	Canadian Standards Association
°F	Degrees Fahrenheit
EPR	Evaporator Pressure regulator
ft (')	Feet
in (")	Inches
hg	Mercury
Hz	Hertz (frequency, cycles per second)
ID	Inside diameter
kcal/h	Kilocalories per hour
kg	Kilogram
kg/cm ²	Kilogram per square centimeter
kw	Kilowatts
lbs	Pounds
lbs/min	Pounds per minute
m	Meter
m ³ /h	Cubic meters per hour
mm	Millimeter
mm hg	Millimeters mercury equivalent vacuum
MOPD	Maximum Opening Pressure Differential
NEMA	National Electrical Manufacturers Association
NPT	National Pipe Thread
OD	Outside Diameter
ODS	Outside Diameter Sweat or tubing O.D., which can be soldered into fitting
psi	Pounds per square inch
psig	Pounds per square inch gauge
sq. cm (cm ²)	Square centimeters
SWP	Safe Working Pressure
TXV	Thermostatic Expansion Valve
UL	Underwriters Laboratories, Inc.
V	Volts

Explanation of Terminology

1. Design pressure (SWP): The maximum allowable working pressure for which a valve or regulator is designed.
2. Evaporator temperature: Saturated temperature in the evaporator.
3. Maximum fluid temperature: The highest normally allowable internal temperature for a particular valve.
4. Maximum Opening Pressure Differential: The maximum difference between the pressure at the valve inlet and the pressure at the valve outlet at which a solenoid will open consistently (MOPD).
5. Minimum fluid temperature: The lowest normally allowable internal temperature for a particular valve assuming a clean, oil-free fluid and the absence of thermal or pressure shock.
6. Net weight: The weight of a particular valve. Does not include shipping cartons.
7. Pressure drop: The pressure difference between the pressure at the valve inlet and the pressure at the valve outlet.
8. Shock: A sudden, violent increase in pressure; can be caused by a rapid change in temperature, pressure, velocity, or direction.
9. Valve or regulator capacity: All capacities are maximum for the conditions listed at each table. No "reserve capacity" is included in this catalog.
10. Conversions to metric:
 1 ton = 200 BTU/min
 1 ton = 3024kcal/hr
 1 kw = .2844 ton
 1 kw = 56.89 BTU/min
 1 kw = 860 kcal/hr
 1 bar = 1.0197 kg/cm²
 1 bar = 14.5 psi
 1 ATM = .98 bar = 14.7 psi

Control Valve Symbols and Functions

							
INLET PRESSURE REGULATOR - (Opens on a rise in inlet pressure. Closes when inlet pressure is below set-point).	OUTLET PRESSURE REGULATOR - (Opens on a drop in outlet pressure. Closes when outlet pressure is above set-point).	DIFFERENTIAL PRESSURE REGULATOR - (Opens on a rise in pressure difference. Closes when pressure difference is below set-point.)	INLET PRESSURE REGULATOR w/ ELECTRIC SHUT-OFF - (Opens on a rise in inlet pressure when energized. Closes when inlet pressure is below set-point or when de-energized.)	INLET PRESSURE REGULATOR w/ ELECTRIC BYPASS - (Opens on a rise in inlet pressure when de-energized. Wide open when energized.)	INLET PRESSURE REGULATOR w/ ELECTRIC SHUT-OFF and ELECTRIC BYPASS - (Opens on a rise in inlet pressure when "S" solenoid energized.) Wide open with "B" solenoid energized. Closes with both solenoids de-energized.)	SOLENOID VALVE - (Opens when energized; closes when de-energized.)	CHECK VALVE - (Permits flow in only one direction).

The items described in this document and other documents or descriptions provided by Parker Hannifin Corporation, its subsidiaries and its authorized distributors are hereby offered for sale at prices to be established by Parker Hannifin Corporation, its subsidiaries and its authorized distributors. This offer and its acceptance by any customer ("Buyer") shall be governed by all of the following Terms and Conditions. Buyer's order for any such items, when communicated to Parker Hannifin Corporation, its subsidiary or an authorized distributor ("Seller") verbally or in writing, shall constitute acceptance of this offer.

1. Terms and Conditions of Sale: All descriptions, quotations, proposals, offers, acknowledgments, acceptances and sales of Seller's products are subject to and shall be governed exclusively by the terms and conditions stated herein. Buyer's acceptance of any offer to sell is limited to these terms and conditions. Any terms or conditions in addition to, or inconsistent with those stated herein, proposed by Buyer in any acceptance of an offer by Seller, are hereby objected to. No such additional, different or inconsistent terms and conditions shall become part of the contract between Buyer and Seller unless expressly accepted in writing by Seller. Seller's acceptance of any offer to purchase by Buyer is expressly conditional upon Buyer's assent to all the terms and conditions stated herein, including any terms in addition to, or inconsistent with those contained in Buyer's offer, Acceptance of Seller's products shall in all events constitute such assent.

2. Payment: Payment shall be made by Buyer net 30 days from the date of delivery of the items purchased hereunder. Amounts not timely paid shall bear interest at the maximum rate permitted by law for each month or portion thereof that the Buyer is late in making payment. Any claims by Buyer for omissions or shortages in a shipment shall be waived unless Seller receives notice thereof within 30 days after Buyer's receipt of the shipment.

3. Delivery: Unless otherwise provided on the face hereof, delivery shall be made F.O.B. Seller's plant. Regardless of the method of delivery, however, risk of loss shall pass to Buyer upon Seller's delivery to a carrier. Any delivery dates shown are approximate only and Seller shall have no liability for any delays in delivery.

4. Warranty: Seller warrants that the items sold hereunder shall be free from defects in material or workmanship for a period of 18 months from date of shipment from Parker Hannifin Corporation. **THIS WARRANTY COMPRISES THE SOLE AND ENTIRE WARRANTY PERTAINING TO ITEMS PROVIDED HEREUNDER. SELLER MAKES NO OTHER WARRANTY, GUARANTEE, OR REPRESENTATION OF ANY KIND WHATSOEVER. ALL OTHER WARRANTIES, INCLUDING BUT NOT LIMITED TO, MERCHANTABILITY AND FITNESS FOR PURPOSE, WHETHER EXPRESS, IMPLIED, OR ARISING BY OPERATION OF LAW, TRADE USAGE, OR COURSE OF DEALING ARE HEREBY DISCLAIMED.**

NOTWITHSTANDING THE FOREGOING, THERE ARE NO WARRANTIES WHATSOEVER ON ITEMS BUILT OR ACQUIRED WHOLLY OR PARTIALLY, TO BUYER'S DESIGNS OR SPECIFICATIONS.

5. Limitation Of Remedy: SELLER'S LIABILITY ARISING FROM OR IN ANY WAY CONNECTED WITH THE ITEMS SOLD OR THIS CONTRACT SHALL BE LIMITED EXCLUSIVELY TO REPAIR OR REPLACEMENT OF THE ITEMS SOLD OR REFUND OF THE PURCHASE PRICE PAID BY BUYER, AT SELLER'S SOLE OPTION. IN NO EVENT SHALL SELLER BE LIABLE FOR ANY INCIDENTAL, CONSEQUENTIAL OR SPECIAL DAMAGES OF ANY KIND OR NATURE WHATSOEVER, INCLUDING BUT NOT LIMITED TO LOST PROFITS ARISING FROM OR IN ANY WAY CONNECTED WITH THIS AGREEMENT OR ITEMS SOLD HEREUNDER, WHETHER ALLEGED TO ARISE FROM BREACH OF CONTRACT, EXPRESS OR IMPLIED WARRANTY, OR IN TORT, INCLUDING WITHOUT LIMITATION, NEGLIGENCE, FAILURE TO WARN OR STRICT LIABILITY.

6. Changes, Reschedules and Cancellations: Buyer may request to modify the designs or specifications for the items sold hereunder as well as the quantities and delivery dates thereof, or may request to cancel all or part of this order, however, no such requested modification or cancellation shall become part of the contract between Buyer and Seller unless accepted by Seller in a written amendment to this Agreement. Acceptance of any such requested modification or cancellation shall be at Seller's discretion, and shall be upon such terms and conditions as Seller may require.

7. Special Tooling: A tooling charge may be imposed for any special tooling, including without limitation, dies, fixtures, molds and patterns, acquired to manufacture items sold pursuant to this contract. Such special tooling shall be and remain Seller's property notwithstanding payment of any charges by Buyer. In no event will Buyer acquire any interest in apparatus belonging to Seller which is utilized in the notwithstanding any charges paid by Buyer. Unless otherwise agreed, Seller shall have the right to alter, discard or otherwise dispose of any special tooling or other property in its sole discretion at any time.

8. Buyer's Property: Any designs, tools, patterns, materials, drawings, confidential information or equipment furnished by Buyer or any other items which become Buyer's property, may be considered obsolete and may be destroyed by Seller after two (2) consecutive years have elapsed without Buyer placing an order for the items which are manufactured using such property, Seller shall not be responsible for any loss or damage to such property while it is in Seller's possession or control.

9. Taxes: Unless otherwise indicated on the face hereof, all prices and charges are exclusive of excise, sales, use, property, occupational or like taxes which may be imposed by any taxing authority upon the manufacture, sale or delivery of the items sold hereunder. If any such taxes must be paid by Seller or if Seller is liable for the collection of such tax, the amount thereof shall be in addition to the amounts for the items sold. Buyer agrees to pay all such taxes or to reimburse Seller therefore upon receipt of its invoice. If Buyer claims exemption from any sales, use or other tax imposed by any taxing authority, Buyer shall save Seller harmless from and against any such tax, together with any interest or penalties thereon which may be assessed if the items are held to be taxable.

10. Indemnity For Infringement of Intellectual Property Rights: Seller shall have no liability for infringement of any patents, trademarks, copyrights, trade dress, trade secrets or similar rights except as provided in this Part 10. Seller will defend and indemnify Buyer against allegations of infringement of U.S. Patents, U.S. Trademarks, copyrights, trade dress and trade secrets (hereinafter 'Intellectual Property Rights'). Seller will defend at its expense and will pay the cost of any settlement or damages awarded in an action brought against Buyer based on an allegation that an item sold pursuant to this contract infringes the Intellectual Property Rights of a third party. Seller's obligation to defend and indemnify Buyer is contingent on Buyer notifying Seller within ten (10) days after Buyer becomes aware of such allegations of infringement, and Seller having sole control over the defense of any allegations or actions including all negotiations for settlement or compromise. If an item sold hereunder is subject to a claim that it infringes the Intellectual Property Rights of a third party, Seller may, at its sole expense and option, procure for Buyer the right to continue using said item, replace or modify said item so as to make it noninfringing, or offer to accept return of said item and return the purchase price less a reasonable allowance for depreciation. Notwithstanding the foregoing, Seller shall have no liability for claims of infringement based on information provided by Buyer, or directed to items delivered hereunder for which the designs are specified in whole or part by Buyer, or infringements resulting from the modification, combination or use in a system of any item sold hereunder. The foregoing provisions of this Part 10 shall constitute Seller's sole and exclusive liability and Buyer's sole and exclusive remedy for infringement of Intellectual Property Rights.

If a claim is based on information provided by Buyer or if the design for an item delivered hereunder is specified in whole or in part by Buyer, Buyer shall defend and indemnify Seller for all costs, expenses or judgments resulting from any claim that such item infringes any patent, trademark, copyright, trade dress, trade secret or any similar right.

11. Force Majeure: Seller does not assume the risk of and shall not be liable for delay or failure to perform any of Seller's obligations by reason of circumstances beyond the reasonable control of Seller (hereinafter 'Events of Force Majeure'). Events of Force Majeure shall include without limitation, accidents, acts of God, strikes or labor disputes, acts, laws, rules or regulations of any government or government agency, fires, floods, delays or failures in delivery of carriers or suppliers, shortages of materials and any other cause beyond Seller's control.

12. Entire Agreement/Governing Law: The terms and conditions set forth herein, together with any amendments, modifications and any different terms or conditions expressly accepted by Seller in writing, shall constitute the entire Agreement concerning the items sold, and there are no oral or other representations or agreements which pertain thereto. This Agreement shall be governed in all respects by the law of the State of Ohio. No actions arising out of the sale of the items sold hereunder or this Agreement may be brought by either party more than two (2) years after the cause of action accrues.

9/91-P

WARNING 

FAILURE OR IMPROPER SELECTION OR IMPROPER USE OF THE PRODUCTS AND/OR SYSTEMS DESCRIBED HEREIN OR RELATED ITEMS CAN CAUSE DEATH, PERSONAL INJURY AND PROPERTY DAMAGE.

This document and other information from Parker Hannifin Corporation, its subsidiaries and authorized distributors provide product and/or system options for further investigation by users having technical expertise. It is important that you analyze all aspects of your application and review the information concerning the product or system in the current product catalog. Due to the variety of operating conditions and applications for these products or systems, the user, through its own analysis and testing, is solely responsible for making the final selection of the products and systems and assuring that all performance, safety and warning requirements of the application are met.

The products described herein, including without limitation, product features, specifications, designs, availability and pricing, are subject to change by Parker Hannifin Corporation and its subsidiaries at any time without notice.

Copyright 1999, Parker Hannifin Corporation, All Rights Reserved. The items described in this document are hereby offered for sale by Parker Hannifin Corporation, its subsidiaries or its authorized distributors. This offer and its acceptance are governed by the provisions stated in the "Offer of Sale"



Parker Hannifin Corporation
Climate & Industrial Controls Group
6035 Parkland Blvd.
Cleveland, Ohio 44124-4141
Telephone: (216) 896-3000
Fax: (216) 896-4008
Web site: www.parker.com/cig

About Parker's Climate & Industrial Controls Group

The Climate and Industrial Controls Group is one of Parker's eight global operating groups. The Group is a leader in the design, manufacture and sale of system controls and protectors to refrigeration and air-conditioning customers worldwide. The Group also provides a wide variety of industrial controls, including solenoid valves, process control valves, and gerotors, for a multitude of applications.



The Climate Controls Division is a leader in the development, design, manufacture and service of thermostatic expansion valves (TXVs) and refrigerant distributors.



The Refrigeration and Air Conditioning Division designs, manufactures and markets system protectors for mobile and stationary refrigeration and air conditioning applications. Products include filter dryers, receivers, accumulators, mufflers, check valves, and spun copper components.



The Skinner Valve Division designs, produces and markets a full spectrum of refrigeration and general purpose solenoid valves. Brand names include Jackes-Evans, Gold Ring, and Skinner.



The Lucifer Valve Division designs, manufactures and distributes industrial solenoid valves for a variety of applications.



The Sinclair Collins Division is a leading manufacturer and supplier of process control valves for a variety of industrial applications.



The Refrigerating Specialties Division manufactures a comprehensive line of valves and related components for use with both ammonia and halocarbon refrigerants in commercial and industrial refrigeration applications.



The Automotive Connectors Division designs, produces and markets quality air conditioning hose and fittings for automotive, heavy duty truck and off-highway applications worldwide.



The Nichols Portland Division is a world leader in the manufacture of gerotors. These products are used in pumping applications wherever fluid needs to be transferred from one place to another.





Parker Hannifin Corporation
 6035 Parkland Blvd.
 Cleveland, Ohio 44124-4141
 Telephone: (216) 896-3000
 Fax: (216) 896-4000
 Web site: www.parker.com

Parker Hannifin Corporation

About Parker Hannifin Corporation

Parker Hannifin is a leading global motion-control company dedicated to delivering premier customer service. A Fortune 500 corporation listed on the New York Stock Exchange (PH), our components and systems comprise over 1,400 product lines that control motion in some 1,000 industrial and aerospace markets. Parker is the only manufacturer to offer its customers a choice of hydraulic, pneumatic, and electromechanical motion-control solutions. Our Company has the largest distribution network in its field, with over 7,500 distributors serving more than 350,000 customers worldwide.

Parker's Charter

To be a leading worldwide manufacturer of components and systems for the builders and users of durable goods. More specifically, we will design, market and manufacture products controlling motion, flow and pressure. We will achieve profitable growth through premier customer service.

Product Information

North American customers seeking product information, the location of a nearby distributor, or repair services will receive prompt attention by calling the Parker Product Information Center at our toll-free number: 1-800-C-PARKER (1-800-272-7537). In the UK, a similar service is available by calling 0500-103-203.

The Aerospace Group is a leader in the development, design, manufacture and servicing of control systems and components for aerospace and related high-technology markets, while achieving growth through premier customer service.



The Climate & Industrial Controls Group designs, manufactures and sells system controls and protectors to refrigeration and air-conditioning customers worldwide. The Group also provides solenoid valves, process control valves, and gerotors for a multitude of industrial applications.

The Fluid Connectors Group designs, manufactures and markets rigid and flexible connectors, and associated products used in pneumatic and fluid systems.



The Seal Group designs, manufactures and distributes industrial and commercial sealing devices and related products by providing superior quality and total customer satisfaction.

The Hydraulics Group designs, produces and markets a full spectrum of hydraulic components and systems to builders and users of industrial and mobile machinery and equipment.



The Filtration Group designs, manufactures and markets quality filtration and clarification products, providing customers with the best value, quality, technical support, and global availability.

The Automation Group is a leading supplier of pneumatic and electromechanical components and systems to automation customers worldwide.



The Instrumentation Group is a global leader in the design, manufacture and distribution of high-quality critical flow components for worldwide process instrumentation, ultra-high-purity, medical and analytical applications.

Refrigerating Specialties Division

Parker Hannifin Corporation
Refrigerating Specialties Division
2445 South 25th Avenue
Broadview, IL 60153-3858
Tel: (708)-681-6300
Fax: (708)-681-6306
Web site: <http://www.parker.com/refspec>

Catalog 611F, 1/00

printed in U.S.A.

The

LEVEL MASTER CONTROL

made for valve types P-H-M-V-W-D-A
benefits you 5 ways...

1 Modulated flow The Level-Master Control provides a modulated flow and maintains practically a static liquid level in the low side.

2 No moving parts The insert bulb controlling the liquid level has no moving parts. Control does not operate through use of a mechanical float device of any kind.

3 Simplified and economical installation The insert bulb can be placed directly in the shell, accumulator or liquid leg for direct contact with refrigerant. Existing float control systems can be easily and economically converted.

4 Not affected by turbulence When agitation occurs in the low side, the effect on the Level-Master is merely that of striking a mean level and holding that level constant.

5 Tight closing is assured by the spring action in the thermostatic expansion valve during shut down periods when the heater element is off and liquid refrigerant is in contact with the bulb.

APPLICATION and INSTALLATION

The SPORLAN Level-Master Control is a positive liquid level control device suitable for application to all flooded evaporators.

DESCRIPTION and OPERATION

The LMC is a standard thermostatic expansion valve equipped with a Level-Master Element. The combination provides a simple, economical and highly effective liquid level control. The bulb of the conventional thermostatic element has been modified to an insert type of bulb which incorporates a low wattage heater. **A 15 watt heater is supplied as standard. For applications below -60°F evaporating temperature specify a special 25 watt heater.**

The insert bulb is installed in the accumulator or surge drum at the point of the desired liquid level. As the level at the insert bulb drops, the electrically added heat increases the pressure within the thermostatic element and opens the valve. As the liquid level at the bulb rises, the electrical input is balanced by the heat transfer from the bulb to the liquid refrigerant and the LMC either modulates or eventually shuts off. The evaporator pressure and spring assist in providing a positive closure.

INSTALLATION — General

The Level-Master Control is applicable to any system which has been specifically designed for flooded operation.

Sporlan is not responsible for system design and, therefore is not liable for any damage arising from faulty design or improper piping, or for misapplication of its products. Figures 2 thru 8 are piping schematics only to illustrate possible methods of applying the LMC valves.

If these valves are applied in any manner other than as described in this bulletin, the Sporlan warranty is void. Actual system piping must be done so as to protect the compressor at all times. This includes protection against overheating, slugging with liquid refrigerant, and trapping of oil in various system locations. Sporlan recommends that recognized piping references, such as equipment manufacturers' literature and the ASHRAE Handbooks be consulted for assistance with this subject.

The valve is usually connected to feed into the surge drum above the liquid level. It can also feed into the

The insert bulb can be installed directly in the shell, surge drum or liquid leg on new or existing installations. Existing float systems can be easily converted by installing the LMC insert bulb in the float chamber.

The Level-Master Control may be installed at any ambient temperature. The element is protected against excessive temperature created by the heater by a thermostatic switch which is an integral part of the heater assembly.

INSTALLATION — Insert Bulb

The insert bulb should be installed at the point where the desired liquid level is to be maintained. **The bulb must be in contact with the refrigerant, i.e., NOT** installed in a well. If the insert bulb is projected directly into the surge drum, it should be shielded so as to prevent the possibility of splash from either the valve feed or the return from the coil. While generally installed in a horizontal position, see Figure 1, it will operate effectively at any angle or vertical position.

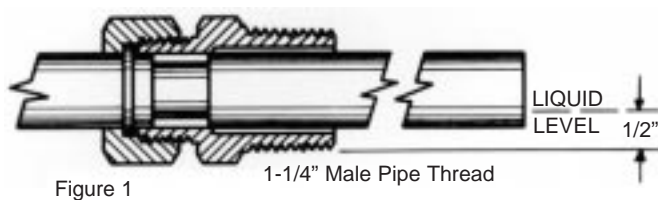

Figure 1

Minor adjustments in liquid level can be made with the adjusting stem provided on the expansion valve. The insert bulb assembly is provided with a lock ring and gasket joint so that the bulb may be removed without breaking the pipe joint.

INSTALLATION — Electrical Connections

The heater is provided with a two wire neoprene covered cord two feet in length. It runs through a moisture-proof grommet and a 1/2" male conduit connection affixed to the insert bulb assembly, see Figure 2.

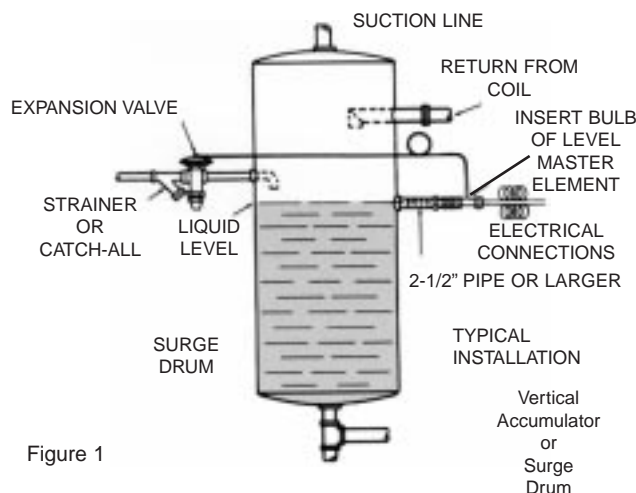

Figure 1

The heater circuit **must** be interrupted when refrigeration is not required and the compressor is cycled off. This will prevent shortening the life of the heater thermostat. To accomplish this, the heater is wired in **parallel** (on the compressor side) with the control or power relay, the holding coil of the compressor magnetic starter, or the liquid line solenoid valve.

DESIGN PRECAUTIONS

HAND VALVES

On installations where the valve is isolated from the surge drum by a hand valve and a 2 to 3 pound pressure drop from the valve outlet to the bulb location is likely, we recommend that an externally equalized valve be used. (See ordering instruction.)

OIL RETURN

General — All reciprocating compressors will allow some oil to pass into the discharge line along with the discharge gas. Mechanical oil separators are used extensively, however, they are never completely effective. The untrapped oil passes through the condenser, liquid line, expansion device and finally into the evaporator.

In a properly designed direct expansion system, the refrigerant velocity in the evaporator tubes and in the suction line is sufficiently high to insure a continuous return of oil to the compressor crankcase. But, this is not characteristic of flooded systems. Here we purposely design the surge drum for a relatively low vapor velocity to prevent entrainment of liquid refrigerant droplets and consequent carry over into the suction line. This design criterion also prevents the return of any oil from the low side in the normal manner.

And if oil is allowed to concentrate at the insert bulb location of the Sporlan Level-Master Control, overfeeding with possible floodback can occur. The tendency to overfeed is due to the fact that the oil does not convey the heat from the low wattage heater element away from the bulb as rapidly as does pure liquid refrigerant. The bulb pressure is higher than normal and the valve remains in the open or partially open position.

Oil and Ammonia Systems — Liquid ammonia and oil are immiscible for all practical purposes. And since the density of oil is greater than that of ammonia it will fall to the bottom of any vessel containing such a mixture if the mixture is relatively placid. Therefore, the removal of oil from an ammonia system is a comparatively simple task. Generally, on systems equipped with a surge drum, the liquid leg is extended downward below the point where the liquid is fed off to the evaporator and a drain valve is provided to allow periodic manual draining as shown in Figure 3.

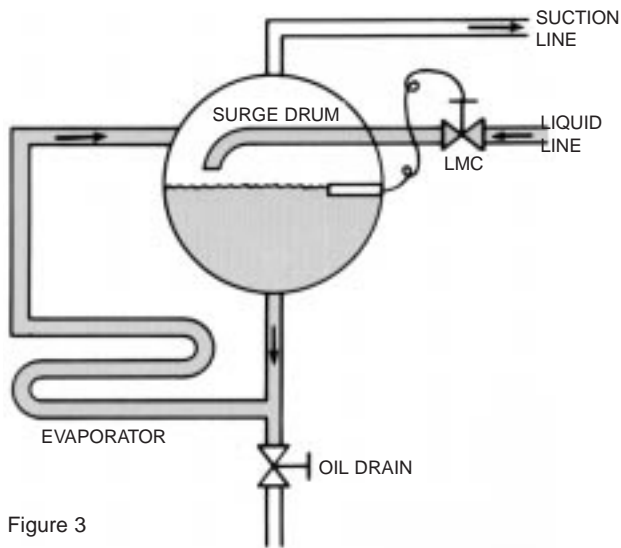

Figure 3

For flooded chillers that do not use a surge drum, a sump with a drain valve is usually provided at the bottom of the chiller shell.

The above methods are quite satisfactory, except possibly on some low temperature systems. Here the drain leg or sump generally has to be warmed prior to attempting to draw off the oil since the trapped oil becomes quite viscous at lower temperatures.

If oil is not drained from a flooded ammonia system a reduction in the evaporator heat transfer rate can occur due to an increase in the refrigerant film resistance. Difficulty in maintaining the proper liquid level with **any type** of flooded control can also be expected.

With a float valve you can expect the liquid level in the evaporator to increase with high concentration of oil in a remote float chamber.

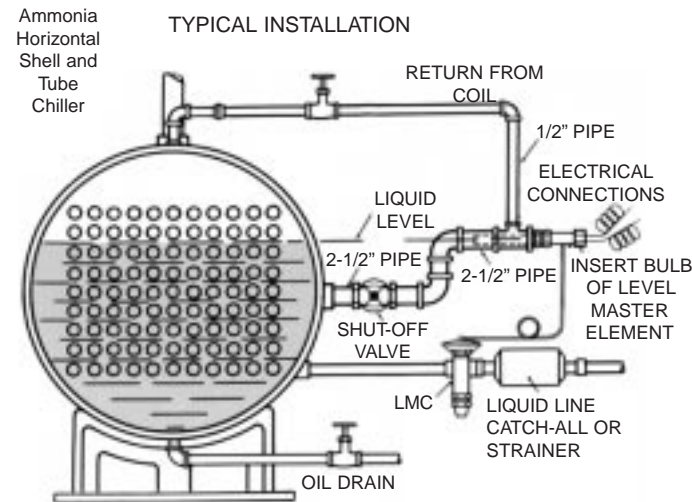

Figure 4

If a Sporlan Level-Master Control is used with the insert bulb installed in a remote chamber, oil concentration at the bulb can cause overfeeding with possible floodback. The lower or liquid balance line must be

free of traps and be free draining into the surge drum or chiller as shown in Figure 4. The oil drain leg or sump must be located at the lowest point in the low side.

Oil and Halocarbon Systems — With Halocarbon systems — Refrigerants 12, 22, 502, etc. — the oil and refrigerant are miscible under certain conditions. Oil is quite soluble in liquid Refrigerant 12 and partially so in liquid Refrigerants 22 and 502. For example, for a 5% (by weight) solution of a typical naphthenic oil in liquid refrigerant, the oil will remain in solution down to about minus 75°F for Refrigerant 12, down to about 0°F for Refrigerant 22, and down to about plus 20°F for Refrigerant 502. Depending upon the type of oil and the percentage of oil present these figures can vary. However, based on the foregoing, we can assume that for the majority of Refrigerant 12 systems the oil and refrigerant are completely miscible at all temperatures normally encountered. But, at temperatures below 0°F with Refrigerant 22 and a 5% oil concentration and temperatures below plus 20°F with Refrigerant 502 and a 5% oil concentration a liquid phase separation occurs. An oil rich solution will appear at the top and a refrigerant rich solution will lay at the bottom of any relatively placid remote bulb chamber.

Oil in a Halocarbon flooded evaporator can produce many effects. Oil as a contaminant will raise the boiling point of the liquid refrigerant — for example with Refrigerant 12, the boiling point increases approximately 1°F for each 5% of oil (by weight) in solution. As in an ammonia system, oil can "foul" the heat transfer surface with a consequent loss in system capacity. Oil can produce "foaming" and possible carry over of liquid into the suction line. Oil can also affect the liquid level control.

With a float valve you can normally expect the liquid level in the evaporator to decrease with increasing concentrations of oil in the float chamber. This is due to the difference in density between the lighter oil in the chamber and lower balance leg and the heavier refrigerant/oil mixture in the evaporator. A lower column of dense mixture in the evaporator will balance a higher column of oil in the remote chamber and piping — this is similar to a "U" tube manometer with a different fluid in each leg.

With the Sporlan Level-Master Control the heat transfer rate at the bulb is decreased producing overfeeding and possible floodback. What can we do? First of all, we must keep the oil concentration as low as possible in the evaporator, surge drum, and remote insert bulb chamber — if one is used. With Refrigerant 12, since the oil/refrigerant mixture is homogenous, we can drain from almost any location in the chiller, surge drum, or remote chamber that is below the liquid level. With Refrigerants 22 and 502, we must locate our drain at or slightly below the surface of the liquid since the oil rich layer is at the top. There are many types of oil return devices:

1. Direct drain into the suction line.
2. Drain through a high pressure liquid warmed heat exchanger.
3. Drain through a heat exchanger with the heat supplied by an electric heater.

The following Figures 5, 6, 7 and 8 are representative of these three methods.

Draining directly into the suction line, as shown in Figure 5, is the simplest method but the hazard of possible floodback to the compressor remains.

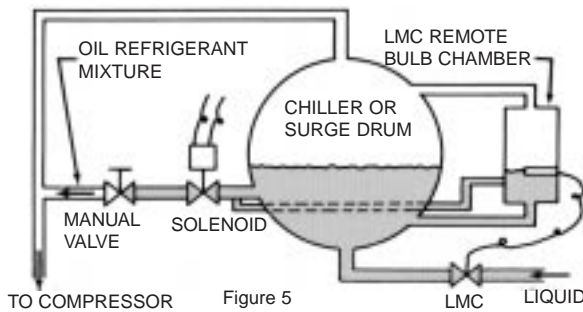

DIRECT DRAIN of oil to the suction line is one of three ways to recover oil in flooded systems. Heat from the environment or a liquid-suction heat exchanger is required to vaporize the liquid refrigerant so drained. Vapor velocity carries oil back to the compressor.

Draining through a heat exchanger as indicated in Figure 6, is a popular method since liquid refrigerant floodback problems are minimized by using the warm liquid to vaporize the liquid refrigerant in the oil/refrigerant mixture.

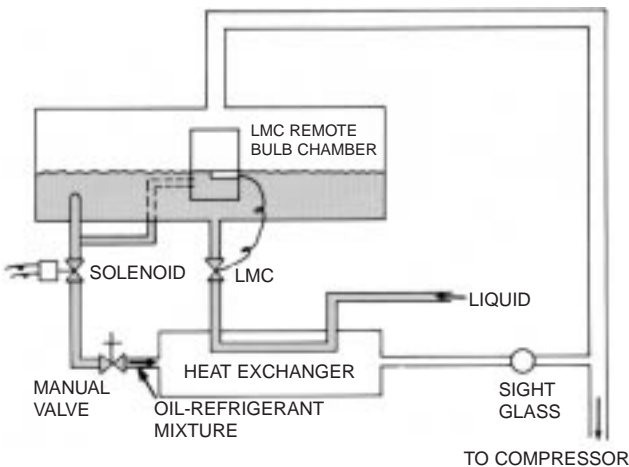

OIL RETURN by draining oil-refrigerant mixture through a heat exchanger is illustrated here. Heat in incoming liquid vaporizes refrigerant to prevent return of liquid to compressor. Liquid feed is controlled by a hand expansion valve.

The use of a heat exchanger with an insert electric heater, as shown in Figure 7, is a variation of the preceding method.

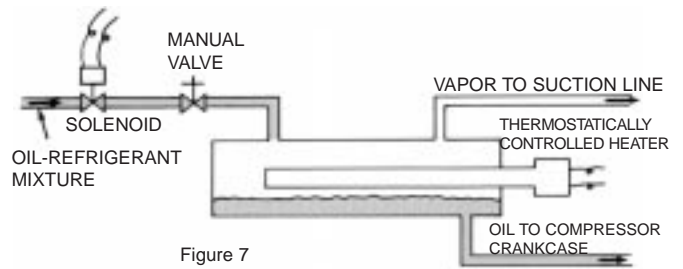

ELECTRIC HEATER may also be used to separate oil and refrigerant. This system is similar to that of Figure 6 except that heat required for vaporization is added electrically.

In all of the oil return arrangements discussed a solenoid valve should be installed in the drain line and arranged to close when the compressor is not in operation. Otherwise liquid refrigerant could drain from the low side into the compressor crankcase during the off cycle.

If the insert bulb is installed directly into the surge drum or chiller, then oil return from this point only is necessary. However, if the insert bulb is located in a remote chamber which is tied to the surge drum or chiller with liquid and gas balance lines then oil return should be made from both locations as shown in Figures 5, 6, and 8.

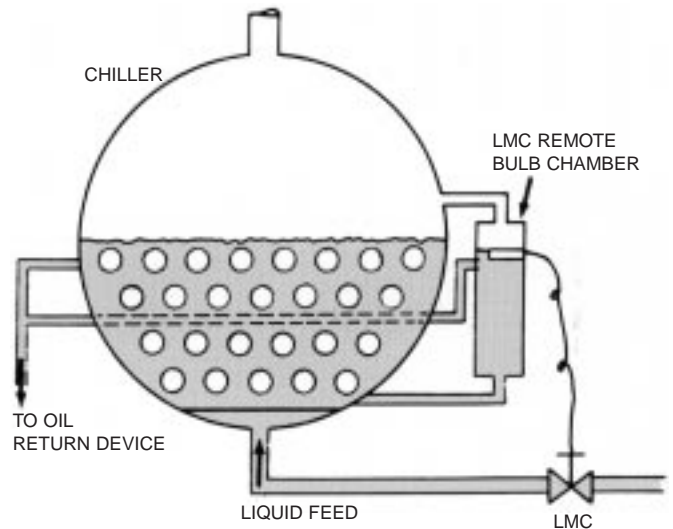

Conclusions — The problem of returning oil from a flooded system is not highly complex and there are undoubtedly other methods in use today that are comparable to those outlined above. *But*, regardless of how it is accomplished, *oil return must be provided* for proper operation of any flooded system — not only with the Sporlan Level-Master Control but with a float or other type of level control device.

CAPACITY IN TONS of REFRIGERATION

CAPACITIES and SELECTION

for Refrigerants 12-22-502-717 (Ammonia)

These ratings are based on vapor free (subcooled) liquid refrigerant entering the expansion valve (100°F for Refrigerants 12, 22, and 502, and 86°F for Refrigerant 717) and standard factory setting. Because of the artificial superheat provided by the electric heater the Level-Master will have a greater capacity than a conventional thermostatic expansion valve. For selections for other refrigerants contact Sporlan Valve Co., Washington, MO 63090.

REFRIGERANT-717 (Ammonia) CAPACITIES																					
LMC Valve Types	Nominal Capacity	EVAPORATOR TEMPERATURES (°F)																			
		10° to 0°					-10°					-20°					-40°				
		PRESSURE DROP ACROSS VALVE (Pounds per square inch)																			
		80	100	120	140	160	100	120	140	160	180	100	120	140	160	180	100	120	140	160	180
D	1	0.94	1.06	1.16	1.25	1.34	0.98	1.07	1.15	1.23	1.31	0.86	0.94	1.01	1.08	1.15	0.59	0.65	0.70	0.75	0.80
	2	2.69	3.01	3.30	3.56	3.80	2.77	3.04	3.28	3.50	3.71	2.44	2.67	2.88	3.08	3.26	1.68	1.85	1.99	2.13	2.26
	5	6.08	6.80	7.45	8.05	8.6	6.26	6.85	7.41	7.91	8.39	5.51	6.03	6.52	6.97	7.39	3.81	4.17	4.51	4.82	5.11
	10	11.0	12.3	13.5	14.6	15.6	11.3	12.4	13.4	14.4	15.2	9.96	10.9	11.8	12.6	13.4	6.89	7.56	8.18	8.74	9.26
	15	15.0	16.8	18.4	19.9	21.3	15.4	16.9	18.3	19.6	20.8	13.6	14.9	16.1	17.2	18.3	9.41	10.3	11.1	11.9	12.6
A	20	17.8	19.8	21.8	23.5	24.1	18.2	20.0	21.6	23.1	24.5	16.0	17.6	19.0	20.3	21.6	11.1	12.2	13.2	14.0	14.9
	30	30.0	33.6	36.8	39.7	42.4	30.9	33.8	36.5	39.0	41.4	27.2	29.8	32.2	34.3	36.4	18.8	20.6	22.2	23.7	25.2
	50	42.7	47.7	52.3	56.5	60.4	43.9	48.1	52.0	55.6	58.9	38.6	42.4	45.8	48.9	51.9	26.7	29.3	31.6	33.8	35.9
	75	75.1	84.0	92.0	99.4	106	77.3	84.6	91.4	97.5	103	68.0	74.5	80.5	85.9	91.1	47.0	51.5	55.7	59.4	63.0
	100	106	118	130	140	150	108	120	129	138	143	95.6	105	113	122	129	66.1	72.8	78.4	84.0	89.1

REFRIGERANT-12 CAPACITIES																					
LMC Valve Types	Nominal Capacity	EVAPORATOR TEMPERATURES (°F)																			
		10° to 0°					-10°					-20°					-40°				
		PRESSURE DROP ACROSS VALVE (Pounds per square inch)																			
		40	60	80	100	120	80	100	120	140	160	80	100	120	140	160	80	100	120	140	160
P-H	1-1/2	1.31	1.6	1.85	2.06	2.26	1.67	1.85	2.03	2.19	2.35	1.48	1.65	1.81	1.95	2.09	1.02	1.13	1.24	1.34	1.44
	4	3.27	4.00	4.62	5.16	5.66	4.15	4.64	5.09	5.50	5.88	3.69	4.12	4.52	4.88	5.22	2.54	2.84	3.11	3.36	3.58
	5	4.08	5.00	5.77	6.45	7.07	5.19	5.80	6.36	6.88	7.34	4.61	5.15	5.65	6.10	6.52	3.17	3.52	3.89	4.20	4.49
	8	6.12	7.50	8.66	9.68	10.6	7.79	8.71	9.55	10.3	11.0	6.92	7.73	8.47	9.16	9.79	4.76	5.32	5.83	6.30	6.74
	12	9.55	11.7	13.5	15.1	16.5	12.2	13.6	14.9	16.1	17.2	10.8	12.1	13.2	14.3	15.3	7.43	8.30	9.10	9.83	10.5
M	15	12.6	15.5	17.9	20.0	21.9	16.1	18.0	10.7	21.3	22.8	14.2	16.0	17.5	18.9	20.2	9.84	11.0	12.1	13.0	13.9
	20	16.3	20.0	23.1	25.8	28.3	20.8	23.2	25.5	27.5	29.4	18.4	20.6	22.6	24.4	26.1	12.7	14.2	15.6	16.8	18.0
	25	20.4	25.0	28.9	32.3	35.4	26.0	29.0	31.8	34.3	36.7	23.1	25.8	28.2	30.5	32.6	15.9	17.7	19.4	21.0	22.4
V	35	28.6	35.0	40.4	45.2	49.5	36.4	40.7	44.5	48.2	51.5	32.3	36.1	39.5	42.7	45.7	22.2	24.9	27.2	29.4	31.5
	45	36.7	45.0	52.0	58.1	63.6	46.8	52.3	56.9	61.8	66.2	41.5	46.4	50.5	54.9	58.7	28.6	31.9	34.8	37.8	40.4
	55	44.9	55.0	63.5	71.0	77.8	57.2	63.9	70.0	75.6	80.8	50.7	56.7	62.2	67.1	71.7	34.9	39.0	42.8	46.2	49.4
W	80	69.4	85.0	98.1	110	120	88.3	98.7	108	117	125	78.4	87.6	96	106	111	53.9	60.3	66.1	71.4	76.3
	110	93.0	114	132	147	161	118	132	145	157	168	105	118	129	139	149	72.4	80.9	88.6	95.7	102

REFRIGERANT-22 CAPACITIES																					
LMC-Valve Types	Nominal Capacity	EVAPORATOR TEMPERATURES (°F)																			
		10° to 0°					-10°					-20°					-40°				
		PRESSURE DROP ACROSS VALVE (Pounds per square inch)																			
		75	100	125	150	175	100	125	150	175	200	100	125	150	175	200	125	150	175	200	225
P-H	2-1/2	2.16	2.50	2.80	3.06	3.31	2.25	2.52	2.75	2.98	3.19	2.00	2.24	2.44	2.64	2.83	1.54	1.68	1.82	1.95	2.06
	5-1/2	4.85	5.60	6.27	6.83	7.41	5.04	5.64	6.17	6.67	7.12	4.47	5.01	5.48	5.92	6.25	3.45	3.77	4.07	4.35	5.16
	7	6.06	7.00	7.92	8.57	9.26	6.30	7.05	7.71	8.33	8.91	5.59	6.26	6.85	7.40	7.82	4.31	4.71	5.09	5.44	5.77
	11	9.1	10.5	11.7	12.8	13.9	9.45	10.5	11.5	12.5	13.4	8.39	9.35	10.2	11.1	11.7	6.43	7.04	7.61	8.17	8.66
	16	13.2	15.2	17.0	18.6	20.1	13.7	15.3	16.7	18.1	1.5	12.1	13.6	14.9	16.1	19.3	9.35	10.2	11.1	11.8	12.5
	20	19.2	22.2	24.8	27.2	29.4	19.9	22.3	24.5	26.5	28.3	17.7	19.8	21.7	23.5	24.8	13.6	15.0	16.2	17.3	18.3
M	26	22.9	26.5	29.6	32.5	35.0	23.9	26.6	29.3	31.5	33.7	21.2	23.6	25.9	28.0	29.6	16.3	17.9	19.2	20.6	21.9
	34	29.4	34.0	38.0	41.6	45.0	30.6	34.2	37.7	40.5	43.3	27.2	30.4	33.5	35.5	38.0	20.9	23.0	24.7	26.4	28.0
	42	36.4	42.0	47.0	51.4	55.6	37.8	42.3	46.3	50.0	53.5	33.6	37.5	41.1	44.4	46.9	25.8	28.3	30.6	32.7	34.6
V	52	45.0	52.0	48.1	63.7	68.7	46.8	52.3	57.3	61.8	66.2	41.5	46.4	50.9	54.9	58.1	31.9	35.0	37.8	40.4	42.1
	70	63.2	73.0	81.6	89.4	96.6	65.7	73.4	80.5	86.9	92.9	58.3	65.2	71.4	77.2	81.5	44.9	49.1	53.1	56.8	60.4
	100	86.2	100	112	122	132	90.0	101	110	119	137	79.0	89.1	97.7	106	112	61.5	67.3	72.8	77.8	82.5
W	135	124	143	160	175	189	129	144	158	170	182	113	126	138	149	160	87.9	96.3	104	111	118
	180	156	180	201	220	238	162	181	198	214	22.9	142	159	174	188	201	111	121	131	140	148

REFRIGERANT-502 CAPACITIES																					
LMC Valve Types	Nominal Capacity	EVAPORATOR TEMPERATURES (°F)																			
		10° to 0°					-10°					-20°					-40°				
		PRESSURE DROP ACROSS VALVE (Pounds per square inch)																			
		75	100	125	150	175	100	125	150	175	200	100	125	150	175	200	125	150	175	200	225
P-H	1-1/2	1.30	1.50	1.68	1.84	1.98	1.35	1.51	1.66	1.78	1.91	1.19	1.33	1.46	1.56	1.67	0.92	1.01	1.09	1.17	1.24
	4	3.46	4.00	4.47	4.90	5.29	3.60	4.02	4.41	4.76	5.09	3.12	3.53	3.87	4.18	4.47	2.46	2.70	2.91	3.11	3.30
	6-1/2	5.62	6.50	7.25	7.96	8.61	5.85	6.53	7.16	7.75	8.24	5.13	5.73	6.29	6.80	7.23	3.99	4.38	4.73	5.03	5.36
	9	8.23	9.50	10.6	11.6	12.6	8.55	9.54	10.4	11.3	12.1	7.50	8.37	9.16	9.95	10.6	5.83	6.38	6.93	7.37	7.84
	12	11.3	13.0	14.5	15.9	17.2	11.7	13.1	14.3	15.5	16.5	10.3	11.5	12.6	13.5	14.5	7.97	8.74	9.46	10.1	10.7
M	15	13.7	15.8	17.7	19.3	20.9	14.2	15.9	17.4	18.8	20.2	12.5	14.0	15.2	16.5	17.7	9.39	10.6	11.5	12.3	13.0
	20	17.8	20.6	23.0	25.2	27.2	18.5	20.7	22.7	24.5	26.3	16.3	18.2	19.9	21.5	23.1	12.6	13.9	15.0	16.0	17.0
	25	22.2	25.7	28.7	31.5	34.0	23.1	25.8	28.4	30.6	32.6	20.3	22.7	24.9	26.9	28.3	15.8	17.3	18.7	19.9	21.2
	30	26.8	31.0	34.7	38.0	41.0	27.9	31.2	34.2	36.9	39.5	24.5	27.4	30.0	32.4	34.7	19.1	20.9	22.5	24.1	25.6
V	38	32.9	38.0	42.5	46.5	50.3	34.2	38.3	41.9	45.3	48.2	30.0	33.6	36.7	39.7	42.3	23.4	25.8	27.7	29.5	31.3
	50	44.2	51.0	57.0	62.5	67.5	45.9	51.3	56.2	60.8	64.9	40.3	45.0	49.4	53.3	56.9	31.3	34.4	37.1	39.6	42.0
	70	60.1	70.0	78.3	85.7	92.6	63.0	70.5	77.1	83.3	90.0	55.3	61.9	67.7	73.1	79.0	43.1	47.1	50.9	55.0	57.8
W	100	88.0	102	114	125	132	92.0	102	112	119	130	80.6	89.9	98.4	104	114	62.6	68.5	72.6	79.1	84.2
	130	112	130	145	159	172	117	131	143	155	165	103	115	126	136	145	79.9	87.6	94.6	101	107

For evaporator temperatures below -40°F, consult Sporlan Valve Company, Washington, MO 63090

These factors include corrections for liquid refrigerant density and net refrigerating effect, and are based on an average evaporator temperature of 0°F. However, they may be used for any evaporator temperature from -40°F to +40°F since the variation in the actual factors across this range is insignificant.

EXAMPLE: At -20°F evaporator, 160 psi pressure drop and 50°F liquid temperature the capacity of an LMC-DA-10 (for ammonia) is
12.6 X 1.11 = 14.0 Tons.

REFRIGERANT LIQUID TEMPERATURE CORRECTION FACTORS

REFRIGERANT	REFRIGERANT LIQUID TEMPERATURE (°F)											
	40°	50°	60°	70°	80°	90°	100°	110°	120°	130°	140°	
12	1.36	1.30	1.24	1.18	1.12	1.06	1.00	0.94	0.88	0.82	0.75	
22	1.34	1.29	1.23	1.17	1.12	1.06	1.00	0.94	0.88	0.82	0.76	
502	1.52	1.44	1.35	1.26	1.18	1.09	1.00	0.91	0.82	0.73	0.64	
REFRIGERANT	0°	10°	20°	30°	40°	50°	60°	70°	80°	86°	90°	100°
717	1.27	1.24	1.20	1.17	1.14	1.11	1.08	1.05	1.02	1.00	0.99	0.96

ORDERING INSTRUCTIONS

Complete Control Valve and Element:

1. Valve type, per specification table. If external equalizer is required, add "E" as sixth letter.
 Example LMC-AAE-20 or LMC-MFE-15.
2. Connection sizes and tubing lengths, if other than standard.
3. Electrical Characteristics

LMC Element only:

Specify voltage, wattage and type number as shown in "Element only" column. (A 15 watt heater is supplied as standard. For applications below -60°F evaporating temperature specify a special 25 watt heater.)

SPECIFICATIONS												
REFRIGERANT-12				REFRIGERANT-22				Standard Connections ODF Inches Sizes shown in Blue Figures will be furnished unless otherwise specified				
Complete Control Valve & Element			Element Only	Complete Control Valve & Element			Element Only	Inlet		Outlet		
INTERNAL EQUALIZER	EXTERNAL EQUALIZER			INTERNAL EQUALIZER	EXTERNAL EQUALIZER							
Straight Sweat Connections												
LMC-PF-1-1/2	LMC-PFE-1-1/2			LMC-PV-2-1/2	LMC-PVE-2-1/2			1/2, 5/8	5/8, 7/8			
—	—			LMC-PV-5-1/2	LMC-PVE-5-1/2							
LMC-PF- 4	LMC-PFE- 4	LMC 33FL		LMC-PV-7	LMC-PVE-7	LMC 33VL		5/8	7/8, 1-1/8, 1-3/8			
LMC-PF- 5	LMC-PFE- 5			LMC-PV-11	LMC-PVE-11							
LMC-PF- 8	LMC-PFE- 8			LMC-PV-16	LMC-PVE-16					1-1/8		
LMC-PF- 12	LMC-PFE- 12			LMC-PV-20	LMC-PVE-20				7/8	1-3/8		
Solder Flange Connections												
LMC-HF- 1-1/2	LMC-HFE- 1-1/2	LMC 33FL		LMC-HV-2-1/2	LMC-HVE-2-1/2	LMC 33VL		1/2, 5/8	5/8, 7/8			
—	—			LMC-HV-5-1/2	LMC-HVE-5-1/2							
LMC-HF- 4	LMC-HFE- 4			LMC-HV-7	LMC-HVE-7				5/8, 7/8	7/8, 1-1/8		
LMC-HF- 5	LMC-HFE- 5			LMC-HV-11	LMC-HVE-11							
—	—			—	—							
LMC-HF-12	LMC-HFE-12	LMC 63FL		LMC-HV-16	LMC-HVE-16	LMC 63VL		7/8	7/8 or 1-1/8			
—	—			LMC-HV-20	LMC-HVE-20							
LMC-MF-15	LMC-MFE-15			LMC-MV-26	LMC-MVE-26				7/8, 1-1/8	1-1/8, 1-3/8		
LMC-MF- 20	LMC-MFE- 20			LMC-MV-34	LMC-MVE-34							
LMC-MF- 25	LMC-MFE- 25			LMC-MV-42	LMC-MVE-42				7/8, 1-1/8			
LMC-VF- 35	LMC-VFE- 35			LMC-VV-52	LMC-VVE-52							
LMC-VF- 45	LMC-VFE- 45			LMC-VV-70	LMC-VVE-70				1-1/8, 1-3/8	1-1/8, 1-3/8		
LMC-VF- 55	LMC-VFE- 55			LMC-VV-100	LMC-VVE-100							
LMC-WF- 80	LMC-WFE- 80			LMC-WV-135	LMC-WVE-135				1-1/8, 1-3/8, 1-5/8, 2-1/8	1-1/8, 1-3/8, 1-5/8, 2-1/8		
LMC-WF- 110	LMC-WFE- 110		LMC 7FL		LMC-WV-180		LMC-WVE-180	LMC 7VL				

1/2", 3/4" or 1" FPT connections also available on request @Standard External Equalizer connection available when specified.

SPECIFICATIONS				
REFRIGERANT-502		Element Only	Standard Connections ODF Inches Sizes shown in Blue Figures will be furnished unless otherwise specified	
Complete Control Valve & Element	INTERNAL EQUALIZER		Inlet	Outlet
	③EXTERNAL EQUALIZER			
Straight Sweat Connections				
LMC-PR-1-1/2	LMC-PRE-1-1/2	LMC 33RL	1/2, 5/8	5/8, 7/8
LMC-PR- 4	LMC-PRE- 4		5/8	7/8, 1-1/8, 1-3/8
LMC-PR- 6-1/2	LMC-PRE- 5			
LMC-PR- 9	LMC-PRE- 8		7/8	1-1/8
LMC-PR- 12	LMC-PRE- 12			1-3/8
Solder Flange Connections				
LMC-HR- 1-1/2	LMC-HRE- 1-1/2	LMC 33RL	1/2, 5/8	5/8, 7/8
LMC-HR- 4	LMC-HRE- 4		5/8, 7/8	7/8, 1-1/8
LMC-HR- 6-1/2	LMC-HRE- 5			
LMC-HR- 9	LMC-HRE- 8		7/8	7/8 or 1-1/8
LMC-HR-12	LMC-HRE-12			
LMC-MR-15	LMC-MRE-15	LMC 63RL	7/8, ②1-1/8	1-1/8, ②1-3/8
LMC-MR- 20	LMC-MRE- 20			
LMC-MR- 25	LMC-MRE- 25		7/8, ②1-1/8	
LMC-MR- 30	LMC-MRE- 30			
LMC-MR- 38	LMC-MRE- 38		1-1/8, ②1-3/8	1-1/8, ②1-3/8
LMC-MR- 50	LMC-MRE- 50			
LMC-MR- 70	LMC-MRE- 70			
LMC-MR- 100	LMC-MRE- 100			
LMC-MR- 130	LMC-MRE- 130	LMC 7RL	1-1/8, 1-3/8 1-5/8, 2-1/8	1-1/8, 1-3/8 1-5/8, 2-1/8

ELECTRICAL SPECIFICATIONS

15 watt, 120v or 240v AC or DC.

120v-25w, 240v-25w, 24v-15w or 25w, are available on special order.

STANDARD CAPILLARY TUBING LENGTH

10 FEET

REPLACEMENT PARTS

INTERNAL PARTS KITS — Same as standard thermostatic expansion valves. Specify valve type, refrigerant and nominal capacity.

HEATER ELEMENT ASSEMBLY

Consists of heater element lead wire, protective thermostatic switch, and moisture proof seal. The standard lead wire length is two feet.

Contact Sporlan Valve Company, Washington, Missouri for capillary tubing lengths and heater element lead wire lengths other than standard.

REFRIGERANT-717 (Ammonia)					
Complete Control Valve & Element		Element Only	Discharge Tube Inches	Standard Connections Inches Sizes shown in Blue Figures will be furnished unless otherwise specified	
INTERNAL EQUALIZER	③EXTERNAL EQUALIZER			Inlet	Outlet
LMC-DA-1	LMC-DAE-1	LMC 23AL	1/32	1/2, 5/8	5/8, 7/8
LMC-DA- 2	LMC-DAE- 2		1/16	5/8	7/8, 1-1/8, 1-3/8
LMC-DA- 5	LMC-DAE- 5		5/64		
LMC-DA- 10	LMC-DAE- 10		7/64	7/8	1-1/8
LMC-DA- 15	LMC-DAE- 15		5/32		1-3/8
LMC-AA- 20	LMC-AAE- 20	LMC 12AL	1/8	1/2, 5/8	5/8, 7/8
LMC-AA- 30	LMC-AAE- 30		5/32		
LMC-AA- 50	LMC-AAE- 50		3/16	5/8, 7/8	7/8, 1-1/8
LMC-AA- 75	LMC-AAE- 75		—		
LMC-AA- 100	LMC-AAE-100		—	7/8	7/8 or 1-1/8

①Has long taper pin. ②1/2", 3/4" or 1" FTP connections also available on request.
③Standard External Equalizer Connection Available when specified.

Element Size	Dimensions Inches		Refrigerant			
	A	B	12 Valves	22 Valves	502 Valves	717 (Ammonia) Valves
No. 12	13.25	7	—	—	—	A
No. 23	8.88	2.62	—	—	—	D
No. 33	8.88	2.62	P-H	P-H	P-H	—
No. 63	13.25	7	M-V-W80	M-V-W135	M-V-W100	—
No. 7	13.25	7	W-110	W-180	W-130	—

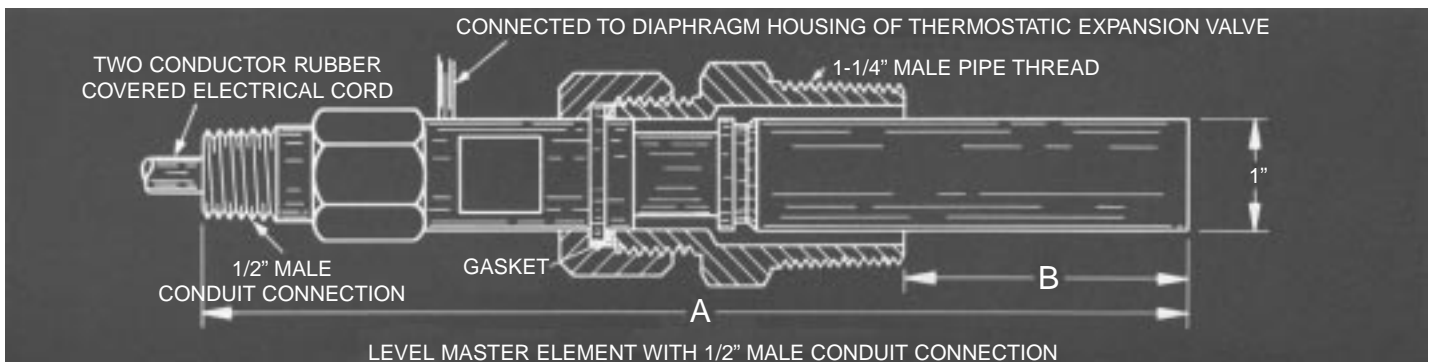

Aparatos de maniobra

3

Contadores principales SIRIUS 3RT

Contadores Principales 3TF

Cambio de contactos principales a partir de 32 Amperios (3RT1034 en adelante).



Mar.30/2000





















No. Depósito	Descripción								Precio Lista Unit. - Bs (*)
	3RT1023		3RT1036		3RT1044				
	Tensión de mando (bobinas): 220, 24, 48, 110 VAC ¹⁾								
	Tipo	Reemplaza al tipo 3TF...	Tamaño	Intensidad (A) AC1 AC3		Potencia del motor (HP) 220 V 440 V		Contactos Auxiliares Integrados	
	Contadores principales tripolares								
941029	3RT1015 - 1AN21	<i>Nuevo</i> 3010-0AN1	S00	18	7	2.0	4.0	1NA	22.600
941030	3RT1023 - 1AN20	3010-0AN1	S0	40	9	3.0	5.5	-	27.600
941040	3RT1023 - 1AN24	4022-0AN1	S0	40	9	3.0	5.5	2NA + 2NC	39.600
941031	3RT1024 - 1AN20	3110-0AN1	S0	40	12	4.0	9.0	-	29.200
941041	3RT1024 - 1AN24	4122-0AN1	S0	40	12	4.0	9.0	2NA + 2NC	42.500
941032	3RT1025 - 1AN20	3200-0AN1	S0	40	17	5.5	12.0	-	41.800
941042	3RT1025 - 1AN24	4222-0AN1	S0	40	17	5.5	12.0	2NA + 2NC	54.300
941033	3RT1026 - 1AN20	3300-0AN1	S0	40	25	9.0	18.0	-	57.700
941043	3RT1026 - 1AN24	4322-0AN1	S0	40	25	9.0	18.0	2NA + 2NC	65.600
941034	3RT1034 - 1AN20	3400-0AN1	S2	50	32	12.0	20.0	-	80.300
941044	3RT1034 - 1AN24	4422-0AN1	S2	50	32	12.0	20.0	2NA + 2NC	96.800
941035	3RT1035 - 1AN20	3500-0AN1	S2	60	40	15.0	30.0	-	102.300
941045	3RT1035 - 1AN24	4522-0AN1	S2	60	40	15.0	30.0	2NA + 2NC	107.600
941046	3RT1036 - 1AN24	4622-0AN1	S2	60	50	20.0	40.0	2NA + 2NC	122.100
941047	3RT1044 - 1AN24	4722-0AN1	S3	100	65	25.0	50.0	2NA + 2NC	158.900
941048	3RT1045 - 1AN24	4822-0AN1	S3	120	80	30.0	60.0	2NA + 2NC	185.400
941049	3RT1046 - 1AN24	<i>Nuevo</i> 4822-0AN1	S3	120	95	35.0	75.0	2NA + 2NC	291.600
	Para contactos auxiliares adicionales, tener en cuenta los bloques de contactos 3RH19 indicados en la siguiente página.								
941050	3TF5022 - 0AN1		6	170	110	45	80	2NA + 2NC	326.600
941051	3TF5122 - 0AN1		6	170	140	55	125	2NA + 2NC	448.000
941052	3TF5222 - 0AN1		8	230	170	70	150	2NA + 2NC	487.200
941054	3TF5422 - 0AN1		10	325	250	110	200	2NA + 2NC	721.100
941056	3TF5622 - 0AN1		12	425	400	170	350	2NA + 2NC	1'026.700
941057	3TF5722 - 0AN1		12	600	475	200	400	2NA + 2NC	1'890.000
941068	3TF6844 - 0CM7 (Contactos en vacío)		14	700	630	275	550	4NA + 4NC	3'137.500
941069	3TF6944 - 0CM7 (Contactos en vacío)		14	910	820	300	600	4NA + 4NC	3'950.000
	Contadores principales tripolares serie 3TF4								
941080	3TF4022 - 0AN1		0	21	9	3.0	5.5	2NA + 2NC	42.800
941081	3TF4122 - 0AN1		0	21	12	4.0	9.0	2NA + 2NC	45.900
941082	3TF4222 - 0AN1		1	32	16	5.5	12.0	2NA + 2NC	58.700
941083	3TF4322 - 0AN1		1	32	22	7.5	15.0	2NA + 2NC	70.900
941084	3TF4422 - 0AN1		2	65	32	12.0	20.0	2NA + 2NC	104.600
941085	3TF4522 - 0AN1		2	65	38	12.5	25.0	2NA + 2NC	116.200
941086	3TF4622 - 0AN1		3	90	45	15.0	30.0	2NA + 2NC	131.900
941087	3TF4722 - 0AN1		3	100	63	25.0	50.0	2NA + 2NC	171.600
941088	3TF4822 - 0AN1		4	120	75	30.0	60.0	2NA + 2NC	200.200
	Notas: ¹⁾ Para selección de Bobinas ver página 3/12. (*) El precio lista no incluye el IVA vigente.								
Cancela y sustituye a la página 3/2 de la Lista con fecha Febrero 1/99 Precios sujetos a cambio sin previo aviso									

Contadores auxiliares SIRIUS 3RH

Bloques de contactos auxiliares para contactores SIRIUS 3RT/3RH



Mar.30/2000

No. Depósito	Descripción					Precio Lista Unit. - Bs (*)
	 Contadores auxiliares 3RH1122					
	Contadores auxiliares con 2NA + 2NC incorporados					
	Tipo	Reemplaza al tipo 3TH...	Tamaño	Tensión (V AC)	Contactos Auxiliares Integrados	
 941422	3RH1122 - 1AP00	3022-0AN1	S00	220	2NA + 2NC	27.000
 941418	3RH1122 - 1AB00	<i>Nuevo</i>	S00	24	2NA + 2NC	27.000
 941420	3RH1122 - 1AH00	<i>Nuevo</i>	S00	48	2NA + 2NC	27.000
 941421	3RH1122 - 1AF00	<i>Nuevo</i>	S00	110	2NA + 2NC	27.000
	Para contactos auxiliares adicionales, tener en cuenta los bloques de contactos 3RH19 indicados abajo.					
	 Bloque de contactos auxiliares (Conexión por tornillos)		 Bloque de contactos auxiliares (Conexión Cage-Clamp)		 Herramienta Cage-Clamp	
	Bloques de contactos auxiliares (Conexión por tornillos). Para todos los contactores Sirius 3RT/3RH					
	Tipo		Tamaño	Contactos Auxiliares	Montaje	
 941322	3RH1911 - 1FA31		S00	3NA + 1NC	Frontal	13.000
 941324	3RH1911 - 1FA22		S00	2NA + 2NC	Frontal	13.000
 941325	3RH1921 - 1LA11		S0 - S3	1NA + 1NC	Frontal	7.800
 941326	3RH1921 - 1FA22		S0 - S3	2NA + 2NC	Frontal	11.600
 941328	3RH1921 - 1DA11		S0 - S3	1NA + 1NC	Lateral	10.200
 941329	3RH1921 - 1CA10		S0 - S3	1NA	Frontal	4.100
 941330	3RH1921 - 1CA01		S0 - S3	1NC	Frontal	4.100
	Bloques de contactos auxiliares (Conexión Cage-Clamp). Para todos los contactores Sirius 3RT/3RH					
 941332	3RH1911 - 2FA31		S00	3NA + 1NC	Frontal	13.800
 941334	3RH1911 - 2FA22		S00	2NA + 2NC	Frontal	13.800
 941336	3RH1921 - 2FA22		S0 - S3	2NA + 2NC	Frontal	13.800
 941338	3RH1921 - 2DA11		S0 - S3	1NA + 1NC	Lateral	9.600
	Herramienta Cage-Clamp					
 941490	8WA2804		100 mm.			3.500
	Notas: (*) El precio lista no incluye el IVA vigente.					
	Página nueva Precios sujetos a cambio sin previo aviso					

Relés Bimetálicos SIRIUS 3RU. Para montaje en contactores SIRIUS 3RT.



Relés Bimetálicos 3UA60/62/66. Para montaje en contactores 3TF.

Relés Electrónicos SIRIUS 3RB. Amplios rangos de regulación (1:4).

Protección contra sobrecarga y marcha en dos fases, clase 10



Mar.30/2000

No. Depósito	Descripción				Precio Lista Unit. - Bs (*)
					
	Relé bimetálico 3RU		Relé de sobrecarga electrónico 3RB		
	Tipo	Tamaño	Regulación (A)	Para Contactores serie SIRIUS	
	Relés Bimetálicos				
914319	3RU1116 - 0JB0	S00	0.7 - 1.0	3RT1015	33.900
914320	3RU1116 - 1AB0	S00	1.1 - 1.6	3RT1015	33.900
914470	3RU1116 - 1BB0	S00	1.4 - 2.0	3RT1015	33.900
914321	3RU1126 - 1CB0	S0	1.8 - 2.5	3RT1023 / 1024 / 1025 / 1026	34.500
914471	3RU1126 - 1DB0	S0	2.2 - 3.2	3RT1023 / 1024 / 1025 / 1026	34.500
914322	3RU1126 - 1EB0	S0	2.8 - 4.0	3RT1023 / 1024 / 1025 / 1026	34.500
914472	3RU1126 - 1FB0	S0	3.5 - 5.0	3RT1023 / 1024 / 1025 / 1026	34.500
914323	3RU1126 - 1GB0	S0	4.5 - 6.3	3RT1023 / 1024 / 1025 / 1026	34.500
914473	3RU1126 - 1HB0	S0	5.5 - 8.0	3RT1023 / 1024 / 1025 / 1026	34.500
914324	3RU1126 - 1JB0	S0	7.0 - 10.0	3RT1023 / 1024 / 1025 / 1026	34.500
914325	3RU1126 - 1KB0	S0	9.0 - 12.5	3RT1023 / 1024 / 1025 / 1026	34.500
914342	3RU1126 - 4AB0	S0	11.0 - 16.0	3RT1023 / 1024 / 1025 / 1026	35.600
914474	3RU1126 - 4BB0	S0	14.0 - 20.0	3RT1023 / 1024 / 1025 / 1026	35.600
914343	3RU1126 - 4DB0	S0	20.0 - 25.0	3RT1023 / 1024 / 1025 / 1026	35.600
914434	3RU1136 - 4DB0	S2	18.0 - 25.0	3RT1034 / 1035 / 1036	49.800
914435	3RU1136 - 4EB0	S2	22.0 - 32.0	3RT1034 / 1035 / 1036	64.000
914436	3RU1136 - 4FB0	S2	28.0 - 40.0	3RT1034 / 1035 / 1036	64.000
914437	3RU1136 - 4HB0	S2	40.0 - 50.0	3RT1034 / 1035 / 1036	78.600
914445	3RU1146 - 4FB0	S3	28.0 - 40.0	3RT1044 / 1045 / 1046	80.500
914446	3RU1146 - 4HB0	S3	36.0 - 50.0	3RT1044 / 1045 / 1046	84.000
914447	3RU1146 - 4JB0	S3	45.0 - 63.0	3RT1044 / 1045 / 1046	90.700
914448	3RU1146 - 4KB0	S3	57.0 - 75.0	3RT1044 / 1045 / 1046	95.000
914449	3RU1146 - 4LB0	S3	70.0 - 90.0	3RT1044 / 1045 / 1046	96.200
914450	3RU1146 - 4MB0	S3	80.0 - 100.0	3RT1044 / 1045 / 1046	125.000
				Para contactores 3TF	
914248	3UA6000 - 2W		63 - 90	3TF50/51	118.000
914249	3UA6000 - 3H		90 - 120	3TF50/51	137.800
914250	3UA6200 - 3H		90 - 120	3TF52/53	151.900
914251	3UA6200 - 3K		120 - 150	3TF52/53	151.900
914252	3UA6200 - 3M		150 - 180	3TF52/53	151.900
914256	3UA6600 - 3C		160 - 250	3TF52/54/56/57/68	378.600
914257	3UA6600 - 3E		250 - 400	3TF54/56/57/68	395.500
	Relés de sobrecarga electrónicos				
914520	3RB1026 - 1RB0	S0	0.1 - 0.4	3RT1023/1024/1025/1026	45.000
914521	3RB1026 - 1NB0	S0	0.4 - 1.6	3RT1023/1024/1025/1026	45.000
914522	3RB1026 - 1PB0	S0	1.6 - 6.0	3RT1023/1024/1025/1026	45.000
914524	3RB1026 - 1QB0	S0	6.0 - 25.0	3RT1023/1024/1025/1026	45.000
914526	3RB1036 - 1UB0	S2	13.0 - 50.0	3RT1034/1035/1036	72.000
914528	3RB1046 - 1EB0	S3	25.0 - 100.0	3RT1044/1045/1046	99.500
	Soportes para colocación independiente del relé				Para relés tipo
914910	3RU1916 - 3AA01	S00		3RU1116	6.300
914911	3RU1926 - 3AA01	S0		3RU1126/3RB1026	7.500
914912	3RU1936 - 3AA01	S2		3RU1136/3RB1036	9.100
914913	3RU1946 - 3AA01	S3		3RU1146/3RB1046	11.700
	Notas: (*) El precio lista no incluye el IVA vigente.				
	Página nueva Precios sujetos a cambio sin previo aviso				

3

Nuevos

Relés bimetálicos 3UA

Para montaje en contactores 3TB4, 3TF3, 3TF4

Con protección contra marcha en dos fases

Mar.30/2000

No. Depósito	Descripción			Precio Lista Unit. - Bs (*)
	<p>Ejecución abierta (IP00), para montaje adosado al contactor, tensión de aislamiento: 660V, con protección contra marcha en dos fases, compensación de temperatura entre - 25°C y + 55°C y ajuste para reenganche manual o automático, contactos auxiliares: 1NA+1NC. Los relés bimetálicos poseen adicionalmente un indicador verde (visible en caso de disparo cuando el relé es operado térmicamente), una tecla de desconexión (= tecla de prueba) y un borne de repetición de la bobina del contactor.</p>			
			 <p>Relé bimetálico 3UA50</p>	
	Tipo	Regulación (A)	Para Contactores	
914019	3UA5000 - 0J	0.63 - 1.0	3TB40/41, 3TF40/41, 3TF30/31	40.700
914020	3UA5000 - 1A	1.0 - 1.6	3TB40/41, 3TF40/41, 3TF30/31	40.700
914021	3UA5000 - 1C	1.6 - 2.5	3TB40/41, 3TF40/41, 3TF30/31	40.700
914022	3UA5000 - 1E	2.5 - 4.0	3TB40/41, 3TF40/41, 3TF30/31	40.700
914023	3UA5000 - 1G	4.0 - 6.3	3TB40/41, 3TF40/41, 3TF30/31	40.700
914024	3UA5000 - 1J	6.3 - 10.0	3TB40/41, 3TF40/41, 3TF30/31	40.700
914025	3UA5000 - 1K	8.0 - 12.5	3TB40/41, 3TF40/41, 3TF30/31	40.700
914040	3UA5200 - 1J	6.3 - 10	3TB42/43, 3TF42/43, 3TF32/33	44.300
914042	3UA5200 - 2A	10 - 16	3TB42/43, 3TF42/43, 3TF32/33	44.300
914043	3UA5200 - 2C	16 - 25	3TB42/43, 3TF42/43, 3TF32/33	44.300
914134	3UA5500 - 2B	12.5 - 20	3TB44, 3TF44/45, 3TF34/35	52.400
914135	3UA5500 - 2D	20 - 32	3TB44, 3TF44/45, 3TF34/35	73.200
914136	3UA5500 - 2R	32 - 40	3TB44, 3TF44/45, 3TF34/35	73.200
914245	3UA5800 - 2D	20 - 32	3TF46/47/48	94.300
914146	3UA5800 - 2F	32 - 50	3TF46/47/48	100.800
914147	3UA5800 - 2P	50 - 63	3TF47/48	108.800
914148	3UA5800 - 2U	63 - 80	3TF48	115.400
	Soportes para colocación independiente del relé bimetálico			
914990	3UX1 418	Para relés 3UA50		12.400
914991	3UX1 420	Para relés 3UA52/54		13.800
914998	3UX1 425	Para relés 3UA55		18.400
914992	3UX1 421 ¹⁾	Para relés 3UA58		15.200
914994	Relé de disparo¹⁾ 3UX1 423	Para relés 3UA66 y 3UA68		65.000
	<p>Notas: ¹⁾ Suministro de importación bajo pedido. (*) El precio lista no incluye el IVA vigente.</p>			

**Cancela y sustituye a la página 3/3 de la lista con fecha Febrero 1/99
Precios sujetos a cambio sin previo aviso**

Guardamotores SIRIUS 3RV

Para protección de motores contra cortocircuito, sobrecarga y marcha en dos fases.

Fijación sobre riel omega de 35 mm.

Limitador de corriente



Mar.30/2000

No. Depósito	Descripción						Precio Lista Unit. - Bs (*)
	 3RV						
	Tipo	Tamaño	Regulación (A)		Potencia del motor (HP)		
			Bimetálico	Cortocircuito	220V	440V	
913001	3RV10 11 - 0JA10	S00	0.7 - 1.0	12	0.25	0.5	55.800
913002	3RV10 11 - 1AA10	S00	1.1 - 1.6	19	0.4	0.75	55.800
913102	3RV10 11 - 1BA10	S00	1.4 - 2.0	24	0.5	1.0	55.800
913003	3RV10 11 - 1CA10	S00	1.8 - 2.5	30	0.75	1.5	55.800
913103	3RV10 11 - 1DA10	S00	2.2 - 3.2	38	1.0	2.0	55.800
913004	3RV10 11 - 1EA10	S00	2.8 - 4.0	48	1.2	2.4	55.800
913104	3RV10 11 - 1FA10	S00	3.5 - 5.0	60	1.5	3.0	55.800
913005	3RV10 11 - 1GA10	S00	4.5 - 6.3	76	2.0	4.0	55.800
913105	3RV10 11 - 1HA10	S00	5.5 - 8.0	96	2.5	5.0	55.800
913006	3RV10 11 - 1JA10	S00	7.0 - 10.0	120	3.0	6.0	62.100
913106	3RV10 11 - 1KA10	S00	9.0 - 12.0	144	4.0	7.5	62.100
913007	3RV10 21 - 4AA10	S0	11.0 - 16.0	192	5.0	10.0	68.400
913008	3RV10 21 - 4BA10	S0	14.0 - 20.0	240	6.6	12.0	68.400
913009	3RV10 21 - 4DA10	S0	20.0 - 25.0	300	9.0	18.0	82.500
913062	3RV10 31 - 4EA10	S2	22.0 - 32.0	384	12.0	24.0	141.700
913063	3RV10 31 - 4FA10	S2	28.0 - 40.0	480	15.0	30.0	164.800
913064	3RV10 31 - 4GA10	S2	36.0 - 45.0	540	18.0	36.0	183.400
913065	3RV10 41 - 4JA10	S3	45.0 - 63.0	756	25.0	50.0	192.100
913066	3RV10 41 - 4KA10	S3	57.0 - 75.0	900	30.0	60.00	192.100
913067¹⁾	3RV10 41 - 4LA10	S3	70.0 - 90.0	1080	36.0	70.00	218.400
913068¹⁾	3RV10 41 - 4MA10	S3	80.0 - 95.0	1140	40.0	75.0	242.000
	Accesorios para guardamotores 3RV²⁾						
913220	3RV19 01 - 1D	Contacto auxiliar conmutable, montaje frontal			1NA - 1NC		8.800
913230	3RV19 13 - 1C	Caja plástica para tamaño S00			IP55		13.500
913231	3RV19 23 - 1C	Caja plástica para tamaño S0			IP55		13.500
913232	3RV19 33 - 1D	Caja plástica para tamaño S2			IP55		43.700
	Accesorios para guardamotores 3VU13/3VU16						
913200	3VU9 131 - 3AA00	Contactos auxiliares			1NA + 1NC		10.600
913209	3VU9 133 - 0CA00	Caja plástica			IP40 (para 3VU13)		13.300
913210	3VU9 133 - 2CA00	Caja plástica con accionamiento giratorio			IP55 (para 3VU13)		18.300
	Notas: ¹⁾ Suministro de importación bajo pedido. ²⁾ Ver módulo de conexión a contactor 3RT en página 3/12 (*) El precio lista no incluye el IVA vigente.						

**Cancela y sustituye a la página 3/5 de la lista con fecha Febrero 1/99
Precios sujetos a cambio sin previo aviso**

Combinación SIRIUS 3RA11 Guardamotor + Contactor

Protección contra cortocircuito, sobrecarga y marcha en dos fases.

Arrancadores directos 3TW en caja

Con protección contra marcha en dos fases.



Mar.30/2000

Producto Nuevo

Combinación Guardamotor + Contactor

La combinación guardamotor + contactor se compone de un guardamotor Sirius 3RV unido a un contactor Sirius 3RT, que forman una sola unidad mediante un dispositivo de acople tanto eléctrico como mecánico.

Con esta combinación es posible el arranque y parada de motores, que incluye protección contra cortocircuito, protección contra sobrecarga y marcha en dos fases.



Combinación Guardamotor + Contactor

No. Depósito	Tipo	Tamaño	Regulación (A)	Potencia (HP)		Precio Lista Unit. - Bs (*)
				220 V	440 V	
941831	3RA1115 - 1A	S00	1.1 - 1.6	0.4	0.9	
941832	3RA1115 - 1B	S00	1.4 - 2.0	0.5	1.2	
941833	3RA1115 - 1C	S00	1.8 - 2.5	0.75	1.5	
941834	3RA1115 - 1D	S00	2.2 - 3.2	0.9	2.0	
941835	3RA1115 - 1E	S00	2.8 - 4.0	1.2	2.4	
941836	3RA1115 - 1F	S00	3.5 - 5.0	1.3	3.0	Precios bajo consulta
941837	3RA1115 - 1G	S00	4.5 - 6.3	2.0	4.0	
941838	3RA1123 - 1H	S0	5.5 - 8.0	2.4	5.0	
941839	3RA1124 - 1J	S0	7.0 - 10.0	3.6	6.6	
941840	3RA1124 - 1K	S0	9.0 - 12.5	4.0	9.0	
941841	3RA1125 - 4A	S0	11.0 - 16.0	5.0	12.0	
941842	3RA1126 - 4B	S0	14.0 - 20.0	6.6	13.0	
941843	3RA1126 - 4D	S0	20.0 - 25.0	9.0	15.0	

Para contactos auxiliares, tener en cuenta los bloques de contactos auxiliares 3RH19 indicados en la página 3/3.

Para potencias superiores, favor consultar.

Arrancadores directos 3TW en caja

(Tensión de mando: 220 VAC)¹⁾

Con contactor, relé bimetalico y botones 0 - I, protección IP41

No. Depósito	Tipo	Regulación (A)	Potencia del motor (HP)		Tamaño NEMA	Precio Lista Unit. - Bs (*)
			220V	440V		
En caja plástica						
941505	3TW0212 - 1CS2	1.6 - 2.5	0.75	1.5	0	65.800
941507	3TW0210 - 1ES2	2.5 - 4.0	1.2	2.4	0	65.800
941509	3TW0210 - 1GS2	4.0 - 6.3	2.0	4.0	0	65.800
941511	3TW0410 - 1JS2	6.3 - 10.0	3.6	7.2	0	68.800
941512	3TW4230 - 2A	10.0 - 16.0	5.0	12.0	0	80.500
941513	3TW4330 - 2C	16.0 - 22.0	7.5	15.0	1	110.300
941515	3TW4430 - 2Q	20.0 - 32.0	12.0	24.0	2	190.800
941516	3TW4530 - 2R	32.0 - 38.0	14.0	28.0	2	227.900
En caja metálica						
941741	3TW4730 - 2F	32 - 50	18	40	2	
941742	3TW4730 - 2P	50 - 63	24	50	2	Precios bajo consulta
941751	3TW4830 - 2U	63 - 75	28	60	3	
941761	3TW5030 - 2W	63 - 90	35	70	4	

Notas: (*) El precio lista no incluye el IVA vigente.

1) Para selección de Bobinas ver página 3/13.

Cancela y sustituye a la página 3/4 de la lista con fecha Octubre 1/99
Precios sujetos a cambio sin previo aviso

3

Arrancadores automáticos estrella-triángulo SIRIUS 3RA14

Arrancadores automáticos estrella-triángulo 3TE

En caja metálica

Con protección de cortocircuito mediante interruptor principal.



Mar.30/2000

No. Depósito	Descripción							Precio Lista Unit. - Bs (*)
	<p>En caja de lámina (IP41). Incluye protección contra corto en los circuitos de fuerza (mediante interruptores SENTRON) y mando (por bornes portafusible 8WA) y contra sobrecarga y marcha en dos fases (relé bimetalico en la fase). Ejecuciones especiales favor consultar.</p>							
	 3RA1436							
	Arrancador estrella triángulo				Potencia del motor (HP)		I Nom. (A)	
Tipo	Tam.	Rango (A) bimetalico	Interruptor principal	220V	440V			
942611	3RA1423 - 1J	S0-S0-S0	7 - 10	CQD/20A	-	12	17	
942612	3RA1424 - 1K	S0-S0-S0	9 - 12.5	CQD/30A	-	15	22	
942621	3RA1425 - 4A	S0-S0-S0	11 - 16	CQD/40A	10	20	28	
942622	3RA1426 - 4B	S0-S0-S0	14 - 20	CQD/40A	12	25	35	
942632	3RA1426 - 4D	S0-S0-S0	20 - 25	CQD/50A	15	35	43	Precios bajo consulta
942642	3RA1436 - 4E	S2-S2-S0	22 - 32	CQD/60A	20	40	55	
942643	3RA1436 - 4F	S2-S2-S0	28 - 40	CQD/80A	25	50	69	
942662	3RA1436 - 4H	S2-S2-S2	40 - 50	CQD/100A	35	70	87	
942671	3RA1444 - 4J	S3-S3-S2	45 - 63	FXD63/125A	45	90	109	
942682	3RA1445 - 4K	S3-S3-S2	57 - 75	FXD63/175A	55	110	130	
942683	3RA1446 - 4L	S3-S3-S2	70 - 90	FXD63/200A	70	140	156	
942701	3TE50 - 3H	6	90 - 110	FXD63/200A	80	175	190	
942720	3TE52 - 3H	6	90 - 120	FXD63/225A	90	180	208	
942721	3TE52 - 3K	8	120 - 150	2 x FXD63/150A	115	230	260	Precios bajo consulta
942722	3TE52 - 3M	8	150 - 180	2 x FXD63/200A	140	280	312	
942741	3TE54 - 3C	10	160 - 250	2 x JXD63/300A	190	380	433	
942742	3TE54 - 3E	10	250 - 278	2 x JXD63/300A	210	420	482	
942761	3TE56 - 3E	12	250 - 400	2 x LXD63/500A	300	600	693	
<p>Notas: (*) El precio lista no incluye el IVA vigente.</p>								
<p>Cancela y sustituye a la página 3/6 de la lista con fecha Febrero 1/99 Precios sujetos a cambio sin previo aviso</p>								

3

Arrancadores electrónicos suaves SIRIUS 3RW30 en caja metálica

Con protección contra cortocircuito, sobrecarga y marcha en dos fases.

Reduce los picos de corriente en el arranque y el desgaste mecánico del accionamiento.

Bypass incorporado



Mar.30/2000

No. Depósito	Descripción						Precio Lista Unit. - Bs (*)
	<p>En caja de lámina (IP41). El precio incluye:</p> <ul style="list-style-type: none"> • Protección contra cortocircuito, sobrecarga y marcha en dos fases mediante Guardamotor Sirius. • Pulsador de arranque y pulsador de parada Signum. • Lámpara de señalización Signum para indicar finalización de rampa de arranque. • Arranque y parada suaves. <p>Ejecuciones especiales favor consultar.</p>						
	Tipo	Tamaño	Rango (A) Guardamotor	I Nominal Motor (A)	Potencia del motor (HP)¹⁾		
					220 V	440 V	
945940	3RW3024 - 4A	S0	11 - 16	12.5	4.0	9.0	
945941	3RW3025 - 4A	S0	11 - 16	16.0	5.0	12.0	
945942	3RW3026 - 4D	S0	20 - 25	25.0	9.0	18.0	
945943	3RW3034 - 4E	S2	22 - 32	32.0	12.0	24.0	Precios
945944	3RW3035 - 4F	S2	28 - 40	38.0	14.0	28.0	bajo
945945	3RW3036 - 4G	S2	36 - 45	45.0	18.0	36.0	consulta
945946	3RW3044 - 4J	S3	45 - 63	63.0	24.0	50.0	
945947	3RW3045 - 4K	S3	57 - 75	75.0	28.0	60.0	
945948 ²⁾	3RW3046 - 4M	S3	80 - 95	100.0	40.0	85.0	
<p>Notas: ¹⁾ Las potencias indicadas son orientativas. La selección correcta del equipo debe hacerse con la corriente nominal del motor. ²⁾ Tiempo de entrega, bajo consulta. (*) El precio lista no incluye el IVA vigente.</p>							
<p>Página nueva Precios sujetos a cambio sin previo aviso</p>							

Inversores de giro SIRIUS 3RA13

Con protección térmica, en caja metálica.



Mar.30/2000

Productos Nuevos

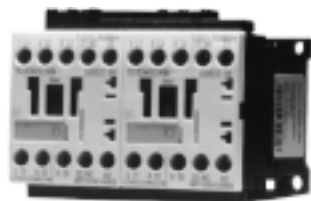

Inversor de giro

Inversor de giro

Incluye 2 contactores con bobina a 220 V, enclavados mecánicamente, con sus respectivos peines de conexión en el lado de alimentación y en el lado de carga.

No. Depósito	Tipo	Intensidad AC3(A)	Potencia del motor (HP)		Tamaño
			220 V	440 V	
943829	3RA1315	7	2.4	4.0	S00
943830	3RA1323	9	3.0	5.5	S0
943831	3RA1324	12	4.0	9.0	S0
943832	3RA1325	17	5.5	12.0	S0
943833	3RA1326	25	9.0	18.0	S0
943834	3RA1334	32	12.0	20.0	S2
943835	3RA1335	40	15.0	30.0	S2
943846	3RA1336	50	15.0	35.0	S2
943847	3RA1344	65	20.0	40.0	S3
943848	3RA1345	80	30.0	60.0	S3
944849	3RA1346	95	35.0	75.0	S3

Precios bajo consulta

Inversor de giro con protección térmica en caja metálica

Incluye 2 contactores con bobina a 220 V, enclavados mecánicamente cada contactor, un conmutador de muletilla I-O-II, 2 lámparas verdes y protección térmica por relé bimetálico, montados en caja de lámina (IP41).

No. Depósito	Tipo	Regulación	Potencia del motor (HP)		Tamaño
			220 V	440 V	
941930	3RA1315 - 0JB0	0.7 - 1.0	0.25	0.5	S00
941931	3RA1315 - 1AB0	1.1 - 1.6	0.4	0.9	S00
941932	3RA1315 - 1BB0	1.4 - 2.0	0.5	1.2	S00
941933	3RA1315 - 1CB0	1.8 - 2.5	0.75	1.5	S00
941334	3RA1323 - 1DB0	2.2 - 3.2	0.9	2.0	S0
941935	3RA1323 - 1EB0	2.8 - 4.0	1.2	2.4	S0
941936	3RA1323 - 1FB0	3.5 - 5.0	1.3	3.0	S0
941937	3RA1323 - 1GB0	4.5 - 6.3	2.0	4.0	S0
941938	3RA1323 - 1HB0	5.5 - 8.0	2.4	5.0	S0
941939	3RA1324 - 1JB0	7.0 - 10.0	3.6	6.6	S0
941940	3RA1324 - 1KB0	9.0 - 12.5	4.0	9.0	S0
941941	3RA1325 - 4AB0	11.0 - 16.0	5.0	12.0	S0
941942	3RA1326 - 4BB0	14.0 - 20.0	6.6	13.0	S0
941943	3RA1326 - 4DB0	20.0 - 25.0	9.0	15.0	S0
941944	3RA1334 - 4EB0	22.0 - 32.0	12.0	20.0	S2
941945	3RA1335 - 4FB0	28.0 - 40.0	13.0	30.0	S2
941946	3RA1336 - 4HB0	40.0 - 50.0	15.0	35.0	S2

Precios bajo consulta

Para potencias superiores, favor consultar.

Notas: (*) El precio lista no incluye el IVA vigente.

¹⁾ Contactos auxiliares adicionales, favor consultar.

Página nueva
Precios sujetos a cambio sin previo aviso

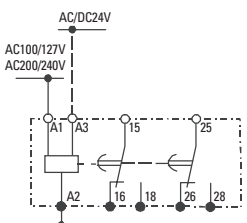
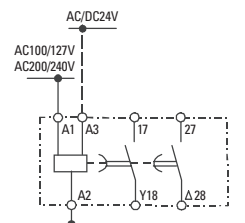
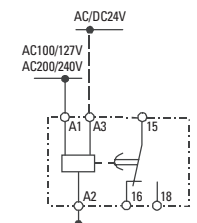
No. Depósito	Descripción				Precio Lista Unit. - Bs (*)
	 <p>Relés de Tiempo 3RP15 74</p> <p>Para montaje en riel tipo Omega de 35 mm. Aislamiento 300V; IP20; I (AC15) = 3A / 22</p>				
	Tipo	Función			
	Relés de tiempo electrónico (Ancho 22,5 mm.)				
940015	3RP1525-1BQ30	24 / 100 - 127 VAC / 24 VDC	0,05 - 100 horas	(15 rangos)	89.500
940016	3RP1525-1BP30	24 / 200 - 240 VAC / 24 VDC	0,05 - 100 horas	(15 rangos)	89.500
	Relés de tiempo electrónicos. Con retardo en la conexión (Ancho 22,5 mm.)				
940008	3RP1574-1NQ30	24/100-127VAC/24 VDC	1 - 20 seg. Y Δ	(reemp. al 7PU6 020 - 7NJ20)	67.000
940009	3RP1574-1NP30	24/200-240VAC/24 VDC	1 - 20 seg. Y Δ	(reemp. al 7PU6 020 - 7NN20)	67.000
940017	3RP15 12- 1AP30	24/200-240VAC/24 VDC	1.5 - 30 seg.	(reemp. al 7PU4 020 - 2AN20)	54.500
940018	3RP15 13- 1AP30	24/200-240VAC/24 VDC	5 - 100 seg.	(reemp. al 7PU4 020 - 3AN20)	54.900
940019	3RP15 25- 1AP30	24/200-240VAC/24 VDC	0.05 seg - 100 hr. (15 rangos)	(reemp. al 7PU4 020 - 4AN20) (reemp. al 7PU4 020 - 4AN20)	62.600
	Relés de tiempo multifunción				
940020	3RP1505-1AQ30	24/100-127VAC/24 VDC	0.05 seg. - 100 hr.		126.000
940021	3RP1505-1BW30	24-240VAC/24-240 VDC	0.05 seg. - 100 hr.		149.800
	Esquemas de conexión interna				
	 <p>Retardo en la conexión conexión 3RP15 25-1B 3RP15 05-1B</p>	 <p>Función estrella-triángulo 3RP15 74-1N</p>	 <p>Retardo en la 3RP15 12-1A 3RP15 13-1A 3RP15 25-1A 3RP15 05-1A</p>		
	Notas: (*) El precio lista no incluye el IVA vigente.				

Cancela y sustituye a la página 3/14 de la lista con fecha Febrero 1/99
Precios sujetos a cambio sin previo aviso

Repuestos para contactores SIRIUS 3RT/3RH

Accesorios para contactores SIRIUS 3R



Mar.30/2000

No. Depósito	Descripción			Precio Lista Unit. - Bs (*)
	 Bobina magnética 3RT1934			
Bobinas magnéticas para corriente alterna				
	Tipo	Para contactores	Tamaño	Tensión (V AC)
941804	3RT1924 - 5AC21	3RT1023 / 1024 / 1025 / 1026	S0	24
941805	3RT1924 - 5AH21	3RT1023 / 1024 / 1025 / 1026	S0	48
941806	3RT1924 - 5AG21	3RT1023 / 1024 / 1025 / 1026	S0	110
941807	3RT1924 - 5AN21	3RT1023 / 1024 / 1025 / 1026	S0	220
941810	3RT1934 - 5AH21	3RT1034	S2	48
941811	3RT1934 - 5AG21	3RT1034	S2	110
941812	3RT1934 - 5AN21	3RT1034	S2	220
941815	3RT1935 - 5AH21	3RT1035 / 1036	S2	48
941816	3RT1935 - 5AG21	3RT1035 / 1036	S2	110
941817	3RT1935 - 5AN21	3RT1035 / 1036	S2	220
941821	3RT1944 - 5AG21	3RT1044	S3	110
941822	3RT1944 - 5AN21	3RT1044	S3	220
941826	3RT1945 - 5AG21	3RT1045 / 1046	S3	110
941827	3RT1945 - 5AN21	3RT1045 / 1046	S3	220
Contactos principales				
941834	3RT1934 - 6A	3RT1034	S2	39.900
941835	3RT1935 - 6A	3RT1035	S2	57.400
941836	3RT1936 - 6A	3RT1036	S2	67.900
941844	3RT1944 - 6A	3RT1044	S3	72.000
941845	3RT1945 - 6A	3RT1045	S3	87.800
941846	3RT1946 - 6A	3RT1046	S3	138.800
Enclavamientos mecánicos				
941380	3RA1924 - 2B	3RT1023 a 3RT1046	S0/S2/S3	19.500
Módulo de conexión Guardamotor 3RV a Contactor 3RT y Arrancador suave 3RW				
	Tipo	Para contactor + guardamotor	Tamaño	
943710	3RA1911 - 1A	3RT101... + 3RV101...	S00	2.800
943112	3RA1921 - 1A	3RT102... + 3RV102...	S0	4.100
943714	3RA1931 - 1A	3RT103... + 3RV103...	S2	4.300
943116	3RA1941 - 1A	3RT104... + 3RV104...	S3	4.500
Notas: (*) El precio lista no incluye el IVA vigente.				
Página Nueva Precios sujetos a cambio sin previo aviso				

Repuestos para contactores 3TF/3TH

Tipos 3TF / 3TH

Mar.30/2000

No. Depósito	Descripción				Precio Lista Unit. - Bs (*)
Bobinas magnéticas para corriente alterna					
Para contactores		Tipo	Tensión (V AC)	Empaque (Unidades)	
941701	3TF40 a 3TF43, 3TF30 a 3TF33, 3TH3, 3TH4, 3TH8, 3TB40 a 3TB44	3TY7 403 - 0AC1	24	10	16.400
941700		3TY7 403 - 0AD6	48	10	16.400
941702		3TY7 403 - 0AG1	110	10	16.400
941703		3TY7 403 - 0AN1	220	10	16.400
941704		3TY7 403 - 0AQ0	440	10	16.400
941706	3TF44/45, 3TF34/35	3TY7 443 - 0AC1	24	10	17.300
941705		3TY7 443 - 0AD6	48	10	17.300
941707		3TY7 443 - 0AG1	110	10	17.300
941708		3TY7 443 - 0AN1	220	10	17.300
941709		3TY7 443 - 0AQ0	440	10	17.300
941710	3TF46/47	3TY7 463 - 0AG1	110	1	24.600
941711		3TY7 463 - 0AN1	220	1	24.600
941712		3TY7 463 - 0AQ0	440	1	24.600
941713	3TF48	3TY7 483 - 0AG1	110	10	51.000
941714		3TY7 483 - 0AN1	220	10	51.000
941715		3TY7 483 - 0AQ0	440	10	51.000
941716	3TF50	3TY7 503 - 0AG1	110	10	57.700
941717		3TY7 503 - 0AN1	220	10	57.700
941718		3TY7 503 - 0AQ0	440	10	57.700
941719	3TF52	3TY7 523 - 0AG1	110	10	63.800
941720		3TY7 523 - 0AN1	220	10	63.800
941721		3TY7 523 - 0AQ0	440	10	63.800
941722	3TF54	3TY7 543 - 0AG1	110	1	88.200
941723		3TY7 543 - 0AN1	220	1	88.200
941724		3TY7 543 - 0AQ0	440	1	88.200
941725	3TF56	3TY7 563 - 0AG1	110	1	110.600
941726		3TY7 563 - 0AN1	220	1	110.600
941727		3TY7 563 - 0AQ0	440	1	110.600
941638	3TF68	3TY7 683 - 0CM7	220	1	425.000
941639	3TF69	3TY7 693 - 0CM7 ¹⁾	220	1	750.000
Contactos principales					
941744	3TF44	3TY7 440 - 0A		1	48.100
941745	3TF45	3TY7 450 - 0A		1	69.300
941746	3TF46	3TY7 460 - 0A		1	81.800
941747	3TF47	3TY7 470 - 0A		1	86.900
941748	3TF48	3TY7 480 - 0A		1	105.800
941750	3TF50	3TY7 500 - 0A		1	167.300
941752	3TF52	3TY7 520 - 0A		1	267.800
941754	3TF54	3TY7 540 - 0A		1	416.500
941756	3TF56	3TY7 560 - 0A		1	590.900
941668	3TF68	3TY7 680 - 0B ¹⁾		1	2'538.000
941669	3TF69	3TY7 690 - 0B ¹⁾		1	2'621.000
Bloques de contactos auxiliares enchufables (Para contactores 3TF3)					
941380	3TX4010 - 2A		10	1NA	3.500
941381	3TX4001 - 2A		10	1NC	3.500
941382	3TX4010 - 3A (Con indicación de estado)		10	1NA	8.400
Enclavamientos mecánicos					
943001	Para contactores similares	3TX7 466 - 1A		3TF44 a 3TF54	40.400
Notas: ¹⁾ Suministro de importación bajo pedido. (*) El precio lista no incluye el IVA vigente.					
Cancela y sustituye a la página 3/8 de la lista con fecha Febrero 1/99 Precios sujetos a cambio sin previo aviso					



Interruptores de protección 5SX y SENTRON

En caja moldeada (MCCB). Aplicación a nivel industrial, comercial y residencial.

Interruptores 5SX. Montaje sobre riel Omega DIN 35 mm.

Interruptores CQD. Montaje con tornillos o sobre riel Omega DIN 35 mm.

Mar.30/2000

No. Depósito	Descripción					Precio Lista Unit. - Bs (*)	
	 CQD		 PXD63B				
	Tipo	Regulación (A)		Capacidad de ruptura (kA) Simétrica			
		Térmica	Cortocircuito	240V	480V	600V	
	Interruptores 5SX						
916316	5SX2 316-7	16	160	16	10	32.000	
916320	5SX2 320-7	20	200	16	10	32.000	
916325	5SX2 325-7	25	250	16	10	32.000	
916332	5SX2 332-7	32	320	16	10	32.000	
916340	5SX2 340-7	40	400	10	6	42.500	
916350	5SX2 350-7	50	500	10	6	66.500	
916363	5SX2 363-7	63	630	10	6	66.500	
916380	5SX7 380-7	80	800	16	10	155.000	
916390	5SX7 391-7	100	1000	16	10	160.000	
	Interruptores Sentron						
913322	CQD315	15	150	65	14	68.100	
913323	CQD320	20	200	65	14	68.100	
913324	CQD330	30	300	65	14	68.100	
913325	CQD340	40	400	65	14	68.100	
913326	CQD350	50	500	65	14	68.100	
913327	CQD360	60	600	65	14	72.400	
913328	CQD380	80	800	65	14	72.400	
913329	CQD3100	100	1000	65	14	72.400	
913640	ED43B125L	125	1000	65	18	120.600	
913641	FXD63B150L	150	800 - 1500	65	35	22	244.500
913642	FXD63B175L	175	900 - 2000	65	35	22	271.200
913643	FXD63B200L	200	900 - 2000	65	35	22	271.200
913644	FXD63B225L	225	1100 - 2500	65	35	22	271.200
913645	FXD63B250L	250	1100 - 2500	65	35	22	271.200
913646	JXD63B300	300	1250 - 2500	65	35	25	445.400
913647	JXD63B350	350	2000 - 4000	65	35	25	445.400
913648	JXD63B400	400	2000 - 4000	65	35	25	445.400
913649	LXD63B500	500	3000 - 6000	65	35	25	890.600
913650	LXD63B600	600	3000 - 6000	65	35	25	890.600
913652	LMXD63B800	800	4000 - 8000	65	50	25	1'455.000
913653	NXD63B100	1000	5000 - 10000	65	50	25	1'900.000
913654	NXD63B120	1200	5000 - 10000	65	50	25	1'900.000
913655	PXD63B140	1400	5000 - 10000	65	50	25	2'992.500
913656	PXD63B160	1600	5000 - 10000	65	50	25	2'992.500
913657	RXD63B180	1800	5000 - 10000	65	50	25	3'325.000
913658	RXD63B200	2000	5000 - 10000	65	50	25	3'325.000
	Notas: (*) El precio lista no incluye el IVA vigente.						
Cancela y sustituye a la página 3/9 de la lista con fecha Febrero 1/99							
Precios sujetos a cambio sin previo aviso							

Interruptores de potencia

Tensión máxima de operación: 690V. Disparadores térmicos y de corto circuito electrónicos graduables.
Disparador de corto circuito brevemente retardado de 0 a 400 ms. Señalización de causas de desconexión
Contactos auxiliares: 2NA + 2 NC. Indicador de disponibilidad de conexión

Mar.30/2000

No. Depósito	Descripción						Precio Lista Unit. - Bs (*)
	 <p>3WN6 / 640 - 1600A</p>						
	Tipo	Regulación (A)		Capacidad de ruptura (kA)			
		Térmica	Cortocircuito	220V	500V	690V	
	Interruptores de potencia fijos con accionamiento manual						
913422	3WN6 161 - 0EB05 - 0AA1	320- 800	1.5 a 12 x lr	65	65	50	3'047.000
913423	3WN6 261 - 0FB05 - 0AA1	400-1000	1.5 a 12 x lr	65	65	50	3'190.000
913424	3WN6 361 - 0GB05 - 0AA1	500-1250	1.5 a 12 x lr	65	65	50	3'796.000
913425	3WN6 461 - 0HB05 - 0AA1	640-1600	1.5 a 12 x lr	65	65	50	5'500.000
913426	3WN6 561 - 0JB05 - 0AA1	800-2000	1.5 a 12 x lr	75	75	50	6'710.000
913427	3WN6 661 - 0KB05 - 0AA1	1000-2500	1.5 a 12 x lr	75	75	50	8'987.000
913428	3WN6 761 - 0MB05 - 0AA1	1280-3200 ⁴⁾	1.5 a 12 x lr	75	75	50	9'790.000
	Interruptores de potencia fijos con accionamiento motorizado a 220V AC/240V DC²⁾						
913442	3WN6 161 - 0EB58 - 0AA1	320- 800	1.5 a 12 x lr	65	65	50	3'850.000
913443	3WN6 261 - 0FB58 - 0AA1	400-1000	1.5 a 12 x lr	65	65	50	4'000.000
913444	3WN6 361 - 0GB58 - 0AA1	500-1250	1.5 a 12 x lr	65	65	50	4'500.000
913445	3WN6 461 - 0HB58 - 0AA1	640-1600	1.5 a 12 x lr	65	65	50	6'100.000
913446	3WN6 561 - 0JB58 - 0AA1	800-2000	1.5 a 12 x lr	75	75	50	7'040.000
913447	3WN6 661 - 0KB58 - 0AA1	1000-2500	1.5 a 12 x lr	75	75	50	9'240.000
913448	3WN6 761 - 0MB58 - 0AA1	1280-3200 ⁴⁾	1.5 a 12 x lr	75	75	50	10'230.000
	Interruptores de potencia extraíbles con accionamiento manual¹⁾³⁾						
913462	3WN6 181 - 0EB05 - 0AA1	320- 800	1.5 a 12 x lr	65	65	50	3'800.000
913463	3WN6 281 - 0FB05 - 0AA1	400-1000	1.5 a 12 x lr	65	65	50	3'950.000
913464	3WN6 381 - 0GB05 - 0AA1	500-1250	1.5 a 12 x lr	65	65	50	4'400.000
913465	3WN6 481 - 0HB05 - 0AA1	640-1600	1.5 a 12 x lr	65	65	50	6'500.000
913466	3WN6 581 - 0JB05 - 0AA1	800-2000	1.5 a 12 x lr	75	75	50	7'900.000
913467	3WN6 681 - 0KB05 - 0AA1	1000-2500	1.5 a 12 x lr	75	75	50	10'450.000
913468	3WN6 781 - 0MB05 - 0AA1	1280-3200 ⁴⁾	1.5 a 12 x lr	75	75	50	12'540.000
	Accesorios para interruptores 3WN6 fijos y extraíbles						
913900	3WX3 631 - 1JK00	Accionamiento motorizado a 220V AC/240V DC ²⁾					1'210.000
913901	3WX3 653 - 1JK00	Bobina de mínima tensión "R" a 220V AC/240V DC ²⁾					341.000
913902	3WX3 651 - 1JK00	Bobina de disparo "F" a 220V AC/240V DC ²⁾					211.200
913930	3WX3 666 - 1JA00 (uno por interruptor)	Enclavamiento mecánico con cable Bowden					495.000
913931	3WX3 666 - 8JA00	Cable Bowden (2m)					101.200
913932	3WX3 686 - 0JA00	Marco para puerta (Protección IP54)					195.800
	Notas: ¹⁾ Suministro de importación bajo pedido. ²⁾ Otras tensiones favor consultar. ³⁾ Otras ejecuciones favor consultar. ⁴⁾ Para corrientes mayores, favor consultar. (*) El precio lista no incluye el IVA vigente.						

**Cancela y sustituye a la página 3/10 de la lista con fecha Febrero 1/99
Precios sujetos a cambio sin previo aviso**

Accesorios para interruptores 5SX y SENTRON



Mar.30/2000

No. Depósito	Descripción		Precio Lista Unit. - Bs (*)
	 <p>Bobinas de disparo y contactos auxiliares</p>		
	Bobina de mínima tensión: tensión de funcionamiento 240 VAC 60Hz		
	Tipo	Para interruptor	
913711	U03FD60	FXD	178.100
913712	U03JLD6	JXD, LXD, LMXD	178.100
913713	U03MN6	NXD, PXD, RXD	253.200
916541	5SX9470	5SX7	55.000
	Bobina de emisión de corriente: tensión de funcionamiento 240 VAC 60Hz		
	Tipo	Para interruptor	
913721	S03FD60	FXD	125.400
913722	S03JLD6	JXD, LXD, LMXD	125.400
913723	S03MN6	NXD, PXD, RXD	163.200
916530	5SX9300	5SX2 (Tensión: 110 - 440 V AC)	56.200
916531	5SX9360	5SX7 (Tensión: 110 - 440 V AC)	50.000
	Contactos auxiliares		
	Tipo	Para interruptor	
913730	CQDA1	CQD	80.300
913731	A01FD62	FXD (voltaje máximo 240 VAC)	80.300
913732	A01JLD64	JXD, LXD, LMXD (voltaje máximo 480 VAC)	80.300
913733	A01MN64	NXD, PXD, RXD (voltaje máximo 480 VAC)	155.500
916510	5SX9100	5SX2	15.000
916511	5SX9160	5SX7	29.800
	Contactos auxiliares de alarma		
	Tipo	Para interruptor	
913740	CQBA	CQD	80.300
913741	B00FD64	FXD (voltaje máximo 240 VAC)	80.300
913742	B01JLD64	JXD, LXD, LMXD (voltaje máximo 480 VAC)	80.300
913743	B00MN64	NXD, PXD, RXD (voltaje máximo 480 VAC)	155.500
916520	5SX9200	5SX2	24.500
916521	5SX9260	5SX7	34.200
	Notas: (*) El precio lista no incluye el IVA vigente.		
Cancela y sustituye a la página 3/11 de la lista con fecha Febrero 1/99 Precios sujetos a cambio sin previo aviso			

3

Accesorios para interruptores SENTRON

Mar.30/2000

No. Depósito	Descripción	Precio Lista Unit. - Bs (*)												
	 <p>Accionamiento motorizado: tensión de funcionamiento 240 VAC 60Hz.</p> <table border="1"> <thead> <tr> <th>Tipo</th> <th>Para interruptor</th> </tr> </thead> <tbody> <tr> <td>MOF6240</td> <td>FXD</td> </tr> <tr> <td>MOJ6240</td> <td>JXD</td> </tr> <tr> <td>MOL6240</td> <td>LXD</td> </tr> <tr> <td>MOLMD6120¹⁾</td> <td>LMXD</td> </tr> <tr> <td>MOMN6240</td> <td>NXD, PXD, RXD</td> </tr> </tbody> </table>	Tipo	Para interruptor	MOF6240	FXD	MOJ6240	JXD	MOL6240	LXD	MOLMD6120 ¹⁾	LMXD	MOMN6240	NXD, PXD, RXD	
Tipo	Para interruptor													
MOF6240	FXD													
MOJ6240	JXD													
MOL6240	LXD													
MOLMD6120 ¹⁾	LMXD													
MOMN6240	NXD, PXD, RXD													
913701		1'028.000												
913702		1'354.000												
913703		1'354.000												
913704		1'354.000												
913705		1'354.000												
	 <p>Enclavamiento mecánico</p> <table border="1"> <thead> <tr> <th>Tipo</th> <th>Para interruptor</th> </tr> </thead> <tbody> <tr> <td>MI5444</td> <td>FXD</td> </tr> <tr> <td>MI5413</td> <td>JXD, LXD</td> </tr> <tr> <td>MI5406</td> <td>LMXD</td> </tr> <tr> <td>MI5404</td> <td>NXD</td> </tr> <tr> <td>MI5405</td> <td>PXD, RXD</td> </tr> </tbody> </table>	Tipo	Para interruptor	MI5444	FXD	MI5413	JXD, LXD	MI5406	LMXD	MI5404	NXD	MI5405	PXD, RXD	
Tipo	Para interruptor													
MI5444	FXD													
MI5413	JXD, LXD													
MI5406	LMXD													
MI5404	NXD													
MI5405	PXD, RXD													
913761		178.000												
913762		178.000												
913763		253.200												
913764		253.200												
913765		288.300												
	 <p>Accionamiento giratorio (montaje en puerta) Longitud fija</p> <table border="1"> <thead> <tr> <th>Tipo</th> <th>Para interruptor</th> </tr> </thead> <tbody> <tr> <td>CRHOFSD</td> <td>FXD</td> </tr> <tr> <td>CRHOJSD</td> <td>JXD, LXD</td> </tr> <tr> <td>CRHOLMSD</td> <td>LMXD</td> </tr> <tr> <td>RHONSD</td> <td>NXD, PXD, RXD</td> </tr> </tbody> </table>	Tipo	Para interruptor	CRHOFSD	FXD	CRHOJSD	JXD, LXD	CRHOLMSD	LMXD	RHONSD	NXD, PXD, RXD			
Tipo	Para interruptor													
CRHOFSD	FXD													
CRHOJSD	JXD, LXD													
CRHOLMSD	LMXD													
RHONSD	NXD, PXD, RXD													
913751		120.500												
913752		120.500												
913753		153.100												
913754		153.100												
	<p>Notas: ¹⁾ Tensión de funcionamiento 120 VAC, 60 HZ. (*) El precio lista no incluye el IVA vigente.</p>													
<p>Cancela y sustituye a la página 3/12 de la lista con fecha Febrero 1/99 Precios sujetos a cambio sin previo aviso</p>														



Interruptores termomagnéticos para montaje en riel OMEGA (DIN)

Elevada capacidad de ruptura: 16 kA según IEC 947-2.

Capacidad de ruptura de 20 kA en corriente continua de 24 a 110 V.

Curva de disparo tipo C.

Mar.30/2000

No. Depósito	Descripción					Precio Lista Unit. - Bs (*)	
	 <p>Monopolar</p>		 <p>Bipolar</p>				
	Tipo	Corriente térmica In (A)	Capacidad de ruptura en (kA)			Empaque (Unidades)	
			110V	220V	440V		
	Interruptores termomagnéticos monopolares						
916100	5SX2 105-7	0.5	16	10	3	12	9.900
916101	5SX2 101-7	1.0	16	10	3	12	9.900
916102	5SX2 102-7	2.0	16	10	3	12	9.900
916103	5SX2 103-7	3.0	16	10	3	12	9.900
916104	5SX2 104-7	4.0	16	10	3	12	9.900
916106	5SX2 106-7	6.0	16	10	3	12	9.900
916110	5SX2 110-7	10.0	16	10	3	12	9.900
916116	5SX2 116-7	16.0	16	10	3	12	9.900
916120	5SX2 120-7	20.0	16	10	3	12	9.900
916125	5SX2 125-7	25.0	16	10	3	12	9.900
916132	5SX2 132-7	32.0	16	10	3	12	9.900
916140	5SX2 140-7	40.0	10	6	3	12	12.600
916150	5SX2 150-7	50.0	10	6	3	12	16.200
916163	5SX2 163-7	63.0	10	6	3	12	16.200
	Interruptores termomagnéticos bipolares, con disparo simultáneo						
916200	5SX2 205-7	0.5		16	10	6	21.000
916201	5SX2 201-7	1.0		16	10	6	21.000
916202	5SX2 202-7	2.0		16	10	6	21.000
916203	5SX2 203-7	3.0		16	10	6	21.000
916204	5SX2 204-7	4.0		16	10	6	21.000
916206	5SX2 206-7	6.0		16	10	6	21.000
916210	5SX2 210-7	10.0		16	10	6	21.000
916216	5SX2 216-7	16.0		16	10	6	21.000
916220	5SX2 220-7	20.0		16	10	6	21.000
916225	5SX2 225-7	25.0		16	10	6	21.000
916232	5SX2 232-7	32.0		15	10	6	21.000
916240	5SX2 240-7	40.0		10	6	6	27.000
916250	5SX2 250-7	50.0		10	6	6	31.500
916263	5SX2 263-7	63.0		10	6	6	31.500
	Notas: (*) El precio lista no incluye el IVA vigente.						
	Página nueva Precios sujetos a cambio sin previo aviso						

Productos Nuevos

Interruptores termomagnéticos para montaje en riel OMEGA (DIN)

Elevada capacidad de ruptura: 16 kA según IEC 947-2.

Capacidad de ruptura de 20 kA en corriente continua de 24 a 110 V.

Curva de disparo tipo C, disparo magnético entre 7 y 10 veces I_n , disparo térmico entre 1,13 y 1,45 veces I_n .

Mar.30/2000

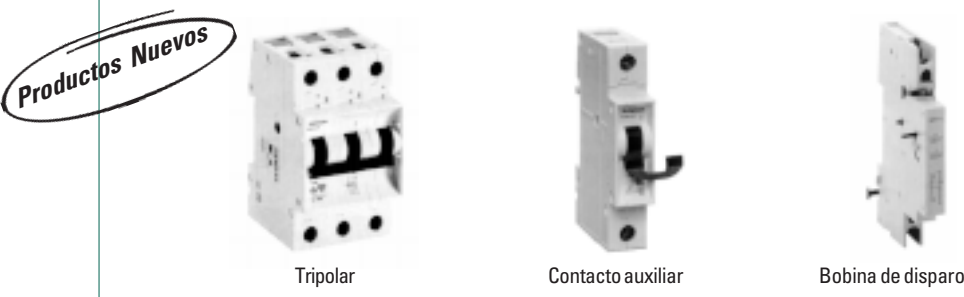
No. Depósito	Descripción				Precio Lista Unit. - Bs (*)	
	 <p style="text-align: center;"> Tripolar Contacto auxiliar Bobina de disparo </p>					
	Tipo	Corriente térmica en I_n (A)	Capacidad de ruptura en (kA)		Empaque (Unidades)	
			220V	440V		
	Interruptores termomagnéticos tripolares, con disparo simultáneo					
916300	5SX2 305-7	0.5	16	10	4	32.000
916301	5SX2 301-7	1.0	16	10	4	32.000
916302	5SX2 302-7	2.0	16	10	4	32.000
916303	5SX2 303-7	3.0	16	10	4	32.000
916304	5SX2 304-7	4.0	16	10	4	32.000
916306	5SX2 306-7	6.0	16	10	4	32.000
916310	5SX2 310-7	10.0	16	10	4	32.000
916316	5SX2 316-7	16.0	16	10	4	32.000
916320	5SX2 320-7	20.0	16	10	4	32.000
916325	5SX2 325-7	25.0	16	10	4	32.000
916332	5SX2 332-7	32.0	16	10	4	32.000
916340	5SX2 340-7	40.0	10	6	4	42.500
916350	5SX2 350-7	50.0	10	6	4	66.500
916363	5SX2 363-7	63.0	10	6	4	66.500
916380	5SX7 380-7	80.0	16	10	2	155.000
916390	5SX7 391-7	100.0	16	10	2	160.000
	Accesorios para interruptores 5SX2					
916510	5SX9 100	Contactos auxiliares		1NA + 1NC	1	15.000
916520	5SX9 200	Contactos auxiliares de señalización por falla		1NA + 1NC	1	24.500
916530	5SX9 300	Bobina de disparo por emisión de corriente		110 - 440VAC	1	56.200
	Accesorios para interruptores 5SX7					
916511	5SX9160	Contactos auxiliares		1NA + 1NC	1	29.800
916521	5SX9260	Contactos auxiliares de señalización por falla		1NA + 1NC	1	34.200
916531	5SX9360	Bobina de disparo por emisión de corriente		110 - 440 V AC	1	50.000
916541	5SX9470	Bobina de mínima tensión		230 V	1	55.000
	Notas: (*) El precio lista no incluye el IVA vigente.					
	Página nueva Precios sujetos a cambio sin previo aviso					



Cortacircuitos automáticos enchufables

Con disparo libre "TRIP".

Tensión de aislamiento: 240V AC.

Aprobación UL 489 y NEMA AB-2. Aprobados según NTC 2116.

Mar.30/2000

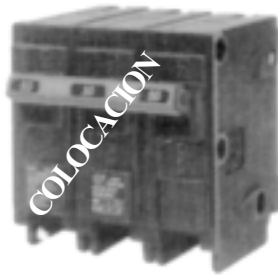
No. Depósito	Descripción				Precio Lista Unit. - Bs (*)
	Gama completa				
					
	Monopolar	Bipolar	Tripolar		
	Tipo	Corriente térmica (A)	Capacidad de ruptura (kA) 120/240V	Empaque (Unidades)	
	Interruptores enchufables monopolares				
915115	Q115	15	10	12	3.200
915120	Q120	20	10	12	3.200
915130	Q130	30	10	12	3.200
915140	Q140	40	10	12	4.350
915150	Q150	50	10	12	4.350
915160	Q160	60	10	12	4.350
915170	Q170	70	10	12	7.200
	Interruptores enchufables bipolares, con disparo simultáneo				
915215	Q215	15	10	6	8.100
915220	Q220	20	10	6	8.100
915230	Q230	30	10	6	8.100
915240	Q240	40	10	6	9.300
915250	Q250	50	10	6	9.300
915260	Q260	60	10	6	9.300
915270	Q270	70	10	6	15.900
915280	Q280	80	10	6	15.900
915290	Q2100	100	10	6	20.200
	Interruptores enchufables tripolares, con disparo simultáneo				
915315	Q315	15	10	4	24.800
915320	Q320	20	10	4	24.800
915330	Q330	30	10	4	24.800
915340	Q340	40	10	4	24.800
915350	Q350	50	10	4	24.800
915360	Q360	60	10	4	24.800
915370	Q370	70	10	4	36.300
915380	Q380	80	10	4	36.300
915390	Q3100	100	10	4	36.300
	Notas: (*) El precio lista no incluye el IVA vigente.				
Cancela y sustituye a la página 3/13 de la lista con fecha Febrero 1/99 Precios sujetos a cambio sin previo aviso					

Módulo Lógico LOGO!

Simplificación en el cableado y montaje de sistemas de control

Con teclas de programación incorporadas.

Múltiples aplicaciones

Mar.30/2000

No. Depósito	Descripción		Precio Lista Unit. - Bs (*)																																																
	<p>Ahora: MAS funciones memoria</p>  <p>Especificaciones técnicas</p> <ul style="list-style-type: none"> - 6 funciones básicas con las cuales se pueden obtener combinaciones de contactos NA y NC en serie y/o paralelo, así como inversores y conmutadores. - 7 funciones especiales tales como retardo a la conexión y desconexión con múltiples rangos de tiempo, contadores adelante / atrás, relés con autorretención, generadores de impulsos, telerruptores y horómetros. - Función de reloj con programación semanal y anual. - Reducido tamaño (72 x 90 x 55 mm. para el 6E/4S y 126 x 90 x 55 mm. para el 12E/8S). - Montaje en riel. - Un display para visualización del estado del programa y parámetros. - Un teclado incorporado que permite la fácil combinación de funciones requeridas (programación sin paneles adicionales). - Interface para módulos de programa (cartuchos de memoria) o para conexión por cable a un PC. - Salidas por relé libre de potencial - Memoria interna EEPROM para almacenar programa y parámetros. <p>Aplicaciones</p> <p>Con LOGO! es posible lograr múltiples aplicaciones dependiendo de la necesidad de control. Por ejemplo, LOGO! es útil en control de sistemas de alternación de bombas, sistemas de ventilación y refrigeración, temporización en el alumbrado de escaleras y bandas transportadoras, puertas y barreras automáticas, automatización de pequeñas máquinas y muchas otras aplicaciones más.</p> <table border="1"> <thead> <tr> <th>Tipo</th> <th>Referencia</th> <th>Tensión de Alimentación</th> <th>Entradas / Salidas</th> <th colspan="2">Corriente máxima de salida</th> </tr> <tr> <th></th> <th></th> <th></th> <th></th> <th>AC1</th> <th>AC3</th> </tr> </thead> <tbody> <tr> <td>951071</td> <td>6ED1 052 - 1FB00 - 0BA1</td> <td>LOGO! 230RC</td> <td>115 - 230 VAC</td> <td>6E/4S</td> <td>8 A 2 A</td> </tr> <tr> <td>951072</td> <td>6ED1 052 - 1HB00 - 0BA1</td> <td>LOGO! 24RC</td> <td>24 VDC</td> <td>6E/4S</td> <td>8 A 2 A</td> </tr> <tr> <td>951075</td> <td>6ED1 052 - 1BB00 - 0BA1</td> <td>LOGO! 12RC</td> <td>12 VDC</td> <td>6E/4S</td> <td>10A 3 A</td> </tr> <tr> <td>951080</td> <td>6ED1 053 - 1FB00 - 0BA1</td> <td>LOGO! 230RCL</td> <td>115 - 230 VAC</td> <td>12E/8S</td> <td>10A 3 A</td> </tr> </tbody> </table> <p>Accesorios</p> <table border="1"> <tbody> <tr> <td>951073</td> <td>6ED1 056 - 1BA00</td> <td>Módulo de memoria LOGO!</td> <td></td> <td></td> <td></td> </tr> <tr> <td>951074</td> <td>6ED1 057 - 1AA00</td> <td>Cable PC - LOGO!</td> <td></td> <td></td> <td></td> </tr> </tbody> </table> <p>Notas: (*) El precio lista no incluye el IVA vigente.</p>		Tipo	Referencia	Tensión de Alimentación	Entradas / Salidas	Corriente máxima de salida						AC1	AC3	951071	6ED1 052 - 1FB00 - 0BA1	LOGO! 230RC	115 - 230 VAC	6E/4S	8 A 2 A	951072	6ED1 052 - 1HB00 - 0BA1	LOGO! 24RC	24 VDC	6E/4S	8 A 2 A	951075	6ED1 052 - 1BB00 - 0BA1	LOGO! 12RC	12 VDC	6E/4S	10A 3 A	951080	6ED1 053 - 1FB00 - 0BA1	LOGO! 230RCL	115 - 230 VAC	12E/8S	10A 3 A	951073	6ED1 056 - 1BA00	Módulo de memoria LOGO!				951074	6ED1 057 - 1AA00	Cable PC - LOGO!				
Tipo	Referencia	Tensión de Alimentación	Entradas / Salidas	Corriente máxima de salida																																															
				AC1	AC3																																														
951071	6ED1 052 - 1FB00 - 0BA1	LOGO! 230RC	115 - 230 VAC	6E/4S	8 A 2 A																																														
951072	6ED1 052 - 1HB00 - 0BA1	LOGO! 24RC	24 VDC	6E/4S	8 A 2 A																																														
951075	6ED1 052 - 1BB00 - 0BA1	LOGO! 12RC	12 VDC	6E/4S	10A 3 A																																														
951080	6ED1 053 - 1FB00 - 0BA1	LOGO! 230RCL	115 - 230 VAC	12E/8S	10A 3 A																																														
951073	6ED1 056 - 1BA00	Módulo de memoria LOGO!																																																	
951074	6ED1 057 - 1AA00	Cable PC - LOGO!																																																	
<p>Cancela y sustituye a la página 3/15 de la lista con fecha Febrero 1/99 Precios sujetos a cambio sin previo aviso</p>																																																			

Aparatos de mando y señalización SIGNUM

Contactos móviles dobles que garantizan una elevada seguridad de contacto.

Diseño en formas planas ergonómicas para mayor comodidad operativa.

Corriente térmica: 10A, protección IP65, diámetro de montaje: 22mm.

Mar.30/2000

No. Depósito	Descripción				Precio Lista Unid. - Bs (*)
	 <p>COLOCACION COLOCACION COLOCACION COLOCACION COLOCACION</p> <p>Pulsador Pulsador hongo Muletilla 0-I + llave Lámpara Pulsador luminoso</p>				
	Pulsadores¹⁾				
	Incluyen pulsador, soporte para fijación posterior y contactos				
926010	3SB3202 - 0AA11	Pulsador negro	+ 1NA		9.900
926011	3SB3203 - 0AA21	Pulsador rojo	+ 1NC		9.900
926210	3SB3203 - 1AA20	Pulsador rojo de hongo 40 mm.	+ 1NC, con retención		19.800
	Conmutadores de muletilla				
	Incluyen muletilla, soporte para fijación posterior y contactos				
926310	3SB3202 - 2KA11	Posiciones 0 - I			14.400
926311	3SB3210 - 2DA11	Posiciones I - 0 - II			18.800
926312	3SB3202 - 4AD11	Posiciones 0 - I con llave de seguridad			23.800
	Lámparas de señalización¹⁾				
	Incluyen casquete, soporte para fijación posterior y portalámpara BA9s, sin bombilla				
927010	3SB3204 - 6AA20	Roja			8.600
927011	3SB3204 - 6AA30	Amarilla			8.600
927012	3SB3204 - 6AA40	Verde			8.600
	Pulsadores luminosos¹⁾				
	Incluyen pulsador con casquete, soporte para fijación posterior, contactos y portalámparas BA9s, sin bombilla				
927610	3SB3207 - 0AA21	Rojo	+ 1NC		15.500
927611	3SB3206 - 0AA31	Amarillo	+ 1NA		15.500
927612	3SB3206 - 0AA41	Verde	+ 1NA		15.500
	Accesorios			Empaque (Unidades)	
929102	3SB3400 - 0A	Bloque de contactos	1NA + 1NC	10	6.600
	Notas: ¹⁾ Otros colores, favor consultar. (*) El precio lista no incluye el IVA vigente.				

Cancela y sustituye a la página 3/16 de la lista con fecha Febrero 1/99
Precios sujetos a cambio sin previo aviso

Aparatos de mando y señalización SIGNUM

Contactos móviles dobles que garantizan una elevada seguridad de contacto.

Diseño en formas planas ergonómicas para mayor comodidad operativa.

Corriente térmica: 10A, protección IP65, diámetro de montaje: 22mm.

Mar.30/2000

No. Depósito	Descripción				Precio Lista Unit. - Bs (*)
					
	Con un elemento	Con dos elementos	Con tres elementos		
Estaciones de mando					
Entrada de conductores por arriba y por abajo. Incluyen caja de material aislante, el accionamiento según su función (pulsador y/o casquete), el soporte para fijación posterior y el elemento de conexión (contactos y/o portalámparas BA9s, sin lámpara)					
	Tipo	Accionamiento	Elemento de conexión	Indicación	
928010	3SB3801 - ODA	1 pulsador verde	1NA	"I"	27.400
928011	3SB3801 - ODB	1 pulsador rojo	1NC	"0"	27.400
928210	3SB3801 - ODC	1 pulsador rojo de hongo, de 40 mm, con retención	1NC	Parte superior amarilla	37.700
928410	3SB3802 - ODA	2 pulsadores (verde, rojo)	1NA, 1NC	"I", "0"	41.200
928510	3SB3803 - ODA	2 pulsadores (verde, rojo), 1 lámpara (transparente)	1NA, 1NC, BA9s	"I", "0"	54.900
					
	Pulsador doble 3SA8 800 - 0AB11				
Programa 3SA8 (30mm.)					
Para montaje frontal incorporado. Tensión de aislamiento: 500V~, 600V-. Protección IP40 al estar montado. I (AC11): 3A a 220V / 2A a 460V.					
	Tipo	Función			
923500	3SA8 800 - 0AB11	Pulsador doble 0-I			16.300
923501	3SA8 810 - 0EB11	Pulsador doble 0-1, con lámpara a 230V.			42.000
Notas: (*) El precio lista no incluye el IVA vigente.					
Cancela y sustituye a la página 3/17 de la lista con fecha Febrero 1/99 Precios sujetos a cambio sin previo aviso					













Interruptores de posición (Fines de carrera)

Contactos móviles dobles que garantizan una elevada seguridad de contacto.

Contactos de acción instantánea.

Alto grado de confiabilidad.

Mar.30/2000

No. Depósito	Descripción	Precio Lista Unit. - Bs (*)
	 <p>3SE3 020</p>	
	<p>Tipo</p> <p>Abiertos (IP00)</p>	
931000	3SE3 020 - 1AA Vástago sencillo de 21 mm.	15.800
	     <p>3SE3 200 - 1G 3SE3 200 1E 3SE3 200-1C 3SE3 200-1D 3SE3 200-1R</p>	
	<p>En caja de material aislante, ancho 31 mm., grado de protección IP66, 1NA + 1NC</p>	
931011	3SE3 200 - 1G Palanca de rodillo de ajuste fino de 10° en 10° Ejecución especial para uso en ambientes polvorientos.	43.500
931012	3SE3 200 - 1E Rodillo y palanca sencilla	38.000
931013	3SE3 200 - 1C Vástago reforzado	29.000
931014	3SE3 200 - 1D Vástago de rodillo	
931015	3SE3 200 - 1R Ejecución especial para uso en ambientes polvorientos. Varilla elástica	37.000 48.500
	<p>Serie SIGUARD</p>        <p>3SE3 120-1UW 3SE3 120-1WW 3SE3 120-1GW 3SE3 120-1B 3SE3 120-1D 3SE3 100-1E 3SE3 100-1R 3SE3 100-1G 3SE3 100-1B 3SE3 100-1D</p>	
	<p>En caja metálica, ancho 40 mm., grado de protección IP67, 1NA + 1NC</p>	
931021	3SE3 120 - 1UW Palanca de rodillo alargable de ajuste fino de 10° en 10°	87.000
931022	3SE3 120 - 1WW Palanca de varilla plástica de ajuste fino de 10° en 10°	82.000
931023	3SE3 120 - 1GW Palanca de rodillo de ajuste fino de 10° en 10°	72.000
931024	3SE3 120 - 1B Vástago sencillo	50.000
931025	3SE3 120 - 1D Vástago de rodillo	74.300
	<p>En caja metálica, ancho 56 mm., grado de protección IP67, 1NA + 1NC</p>	
931031	3SE3 100 - 1EA Rodillo y palanca sencilla, accionamiento de plástico	34.000
931032	3SE3 100 - 1GW Palanca de rodillo de ajuste fino de 10° en 10°	58.900
931033	3SE3 100 - 1R Varilla elástica	81.500
931034	3SE3 100 - 1B Vástago sencillo	49.800
931035	3SE3 100 - 1D Vástago de rodillo	73.800
	<p>Notas: (*) El precio lista no incluye el IVA vigente.</p>	
	<p>Página nueva Precios sujetos a cambio sin previo aviso</p>	

Detectores de proximidad Fotoeléctricos

Protección contra conexión y desconexión intempestivas,
contra inversión de polaridad, contra inducción y contra corto circuito.



Mar.30/2000

Productos Nuevos



Sistema de proximidad (Autoreflex)

Cuerpo plástico reforzado de fibra de vidrio, con LED de indicación, Protección IP67

Tipo	Alcance (mt)	Dimensiones (mm)	Voltaje	Salida	Cargabilidad	Conectable en
------	--------------	------------------	---------	--------	--------------	---------------

932101	3RG7620-1RH60	0.08	M18x55	10-30 Vdc	pnp/npn	150 mA	Claridad/oscuridad	Precios bajo consulta
932102	3RG7620-1RH00	0.3	M18x65	10-30 Vdc	pnp/npn	150 mA	Claridad/oscuridad	
931103	3RG7210-6MC00 ¹⁾	2	83x61x25	AC/DC 20-265 V	Relé	2A	Claridad/oscuridad	

Sistema de proximidad con borrado de fondo

Cuerpo plástico reforzado de fibra de vidrio, con LED de indicación, Protección IP65/IP67

932110	3RG7010-0AB00 ¹⁾	0.3-1.50	30x30x15	10-36 Vdc	pnp	200 mA	Claridad ²⁾	Precios bajo consulta
932111	3RG7214-6MC00 ¹⁾	0.2-1	83x61x25	AC/DC 20-265 V	Relé	2A	Claridad/oscuridad	

Sistema Reflex

Conectable en claridad y oscuridad, cuerpo plástico reforzado de fibra de vidrio, con LED de indicación, Protección IP67

Tipo	Alcance (mt)	Dimensiones (mm)	Voltaje	Salida	Cargabilidad	Reflector (Pág. 3/24)
------	--------------	------------------	---------	--------	--------------	-----------------------

932115	3RG7601-1RH00	2	M18x68	10-30 Vdc	pnp/npn	150 mA	3RX7922	Precios bajo consulta
932116	3RG7011-0CC00	4	30x30x15	10-36 Vdc	pnp	200 mA	3RX7916/915	
932117	3RG7201-6CC00 ¹⁾	6	83x61x25	10-36 Vdc	pnp	200 mA	3RX7916/915	Precios bajo consulta
932118	3RG7211-6MC00 ¹⁾	6	83x61x25	AC/DC 20-265 V	Relé	2A	3RX7916/915	

Sistema Barrera

Cuerpo en lámina niquelada o plástico reforzado de fibra de vidrio, con LED de indicación, Protección IP67

Tipo	Alcance (mt)	Dimensiones (mm)	Voltaje	Salida	Cargabilidad	Conectable en
------	--------------	------------------	---------	--------	--------------	---------------

932122	3RG7132-0BG00	6	M18x50	10-36Vdc	Emisor	200 mA	claridad
932123	3RG7132-0AB00		M18x50	10-36Vdc			
932124	3RG7622-1BG00	12	M18x55	10-30Vdc	Emisor	150 mA	claridad/oscuridad
932125	3RG7622-1RH00		M18x65	10-30Vdc			
932126	3RG7202-6FG00 ¹⁾	25	81x61x25	AC/DC 20-265V	Emisor	2A	claridad/oscuridad
932127	3RG7212-6MC00 ¹⁾		83x61x25	AC/DC 20-265V			

Notas: 1) El ángulo de fijación se pide por separado
2) Conectable en claridad: la luz da en el receptor
Conectable en oscuridad: la luz "no" da en el receptor
(*) El precio lista no incluye el IVA vigente.

Página Nueva
Precios sujetos a cambio sin previo aviso

3

Detectores de proximidad Fotoeléctricos
Detectores de proximidad Capacitivos
Detectores de proximidad Ultrasónicos



Mar.30/2000

Productos Nuevos

No. Depósito	Descripción							Precio Lista Unit. - Bs (*)	
	Lector de marcas impresas Cuerpo de aluminio, con dos LEDs de indicación, protección IP67								
	Tipo	Alcance (mt)	Dimensiones (mm)	Voltaje	Salida	Cargabilidad	Conectable en		
932134	3RG7560-1CH54	18	31x83x62	10-30Vdc	pnp	200 mA	claridad/oscuridad	Precios bajo consulta	
	BERO para conductores de fibra óptica Cuerpo plástico reforzado de fibra de vidrio, con dos LEDs de indicación, Protección IP67								
932135	3RG7013-0CC00	Depende de la fibra 30x30x15		10-36Vdc	pnp	200 mA	Claridad/oscuridad	Precios bajo consulta	
	Accesorios								
932140	3RX7916	Reflector D84 para detectores 3RG70 y 3RG72, diámetro 85 mm (100% de alcance)							
932141	3RX7915	Reflector D40 para detectores 3RG70 y 3RG72, diámetro 46 mm (60% de alcance respecto al D84)							Precios bajo consulta
932142	3RX7922	Reflector S48 para detectores 3RG76, forma hexagonal							Precios bajo consulta
932145	3RX7303	Angulo de fijación para detectores tipo 3RG72							Precios bajo consulta
932146	3RX7910	Angulo de fijación para detectores tipo 3RG70							
	Detectores de proximidad Capacitivos Con protección contra inversión de polaridad, contra anti-inducción, contra cortocircuitos y sobrecargas, Cuerpo de material aislante o de metal con Cabeza de Material Aislante, montaje Rasante, con LED de indicación, Protección IP67								
	Tipo	Alcance (mm)	Dimensiones (mm)	Voltaje	Salida	Cargabilidad	Contactos		
932155	3RG1613-0AB00	5	M18x82	10-65Vdc	pnp	200 mA	NA	Precios bajo consulta	
932156	3RG1614-0AC00	10	M30x81	10-65Vdc	pnp	200 mA	NA/NC	Precios bajo consulta	
932157	3RG1655-6AC00	20	diam. 40	10-65Vdc	pnp	200 mA	NA/NC	Precios bajo consulta	
932158	3RG1655-6LD00	20	diam. 40	20-250Vac	relé	500 mA	NA o NC	Precios bajo consulta	
	Detectores de proximidad ultrasónicos Sonar - BERO								
932165	3RG6342-3AB00	6 - 30	88x65x30	24 Vdc	pnp	100	NA		
932166	3RG6343-3AB00	20 - 100	88x65x25	24 Vdc	pnp	100	NA		
	<u>Con 2 límites de actuación ajustables</u>								
932171	3RG6013-3AD00	20 - 100	M30x131	24 Vdc	pnp	300	NA	Precios bajo consulta	
932172	3RG6014-3AD00	80 - 600	diam. 65	24 Vdc	pnp	300	NA	Precios bajo consulta	
	<u>Conectores</u>								
932175	3RX1505	Conector de cable recto M12 para Sonar-BERO							
932176	3RX1502	Conector de cable angular M12 para Sonar-BERO							
	Notas: (*) El precio lista no incluye el IVA vigente.								
Página Nueva Precios sujetos a cambio sin previo aviso									

3



Bornes de conexión 8WA

Con las dos caras cubiertas en material aislante thermoplast.

Montaje rápido sobre riel omega de 35 mm.

Nueva serie 8WA2 con conexión Cage-Clamp.

Mar.30/2000

No. Depósito	Descripción						Precio Lista Unit. - Bs (*)
	 <p>Bornes 8WA2</p>		 <p>Juego de bornes 8WA1</p>				
Bornes de conexión individuales							
	Tipo	Corriente (A)	Conductores (AWG)	Ancho (mm)	Empaque (Unidades)		
980010	8WA2 011 - 1DF20 Cage-Clamp	24	28-14	5.2	100	990	
980011	8WA2 011 - 1DG20 Cage-Clamp	32	28-12	6.2	100	1.170	
980012	8WA2 011 - 1DH20 Cage-Clamp	41	24-10	8.2	100	1.600	
980013	8WA1 204	82	12-4	10	50	2.250	
980014	8WA1 205	135	10-1	16	50	4.800	
980015	8WA1 206	207	8-3/0	25	10	20.000	
980016	8WA1 207	250	1/0-250 MCM	41	6	30.000	
980017	8WA1 208	382	2/0-500 MCM	45	5	46.500	
Bloques de bornes de conexión (10 bornes por grupo)							
Grupos de 10 bornes en una unidad compacta, que ahorran tiempo de montaje. Los datos de corriente y calibre de conductores aquí indicados, se refieren a cada borne individual.							
981010	8WA1 011 - 0DF21	26	22-12	61.0	2	9.300	
981020	8WA1 011 - 0DG21	34	18-10	65.5	2	10.700	
Bornes portafusibles							
Para utilizar fusibles hasta de 6,3A/250V, de 5x 20 mm. Permite cambiar el fusible, sin tensión							
981100	8WA2 011 - 1SG20 Cage-Clamp	6,3	28-12	10.0	50	4.950	
Bornes de conexión a tierra							
Con los cuales se materializa físicamente la unión con el riel. En color verde - amarillo, para fácil identificación. Vienen provistos para realizar dos conexiones por tornillo.							
982010	8WA2 011 - 1PF20 Cage-Clamp	—	28-14	5.2	100	3.200	
982020	8WA2 011 - 1PG20 Cage-Clamp	—	28-12	6.2	100	3.300	
982030	8WA2 011 - 1PH20 Cage-Clamp	—	24-10	8.2	100	3.800	
Notas: (*) El precio lista no incluye el IVA vigente.							
Cancela y sustituye a la página 3/18 de la lista con fecha _Febrero 1/99 Precios sujetos a cambio sin previo aviso							

Bornes de conexión

Con las dos caras cubiertas en material aislante thermoplast

Montaje rápido sobre riel omega de 35 mm

Nueva serie 8WA2 con conexión Cage-Clamp.

Mar.30/2000

No. Depósito	Descripción	Empaque (Unidades)	Precio Lista Unit. - Bs (*)
Accesorios			
983100	8WA1 808 Escuadra final para bornes 8WA1	50	1.200
983101	8WA2 808 Escuadra final para bornes 8WA2	100	1.200
983120	8WA1 820 Separador para bornes de 24 a 41A para bornes 8WA2	50	570
983121	8WA1 821 Separador para bornes de 44 y 82A para bornes 8WA2	100	570
983140	8WA1 832 Tapa cubrebornes para bornes 8WA1 207	10	2.400
983141	8WA1 833 Tapa cubrebornes para bornes 8WA1 208	10	4.100
983108	8WA2 831 Puente doble para bornes 8WA2	100	470
983109	8WA2 832 Puente sencillo (8WA2) para utilizar con barra de conexión	100	470
983110	8WA2 830 Barra de conexión (8WA2) para utilizar con puentes sencillos. Long: 100 mm.	20	4.100
983112	8WA1 898 Tira de 10 puentes de conexión para bornes 8WA1 011-1DF11	10	3.300
983214	8WA1 853 Tira de 10 puentes de conexión para bornes 8WA1 011-1DG11	10	4.100
983116	8WA1 888 Tira de 10 puentes de conexión para bornes 8WA1 011-1DH11	10	4.500
Placas de designación para bornes 8WA1 / 8WA2			
984001	8WA8 868- 1DA Paquete de 240 placas de designación 1-40 (6 tiras)	1	27.300
984011	8WA8 868- 1DB Paquete de 240 placas de designación 41 - 100 (4 tiras)	1	27.300
984021	8WA8 868- 2DB Paquete de 240 placas de designación U, V, W, X, Y, Z (36 c/u); +, - (12 c/u)	1	27.300
984031	8WA8 868- 2DC Paquete de 240 placas de designación L1, L2, L3, N, PE (5 tiras)	1	27.300
Herramienta Cage-Clamp			
941490	8WA2 804 100mm.		3.500
Notas: (*) El precio lista no incluye el IVA vigente.			
Cancela y sustituye a la página 3/19 de la lista con fecha Febrero 1/99 Precios sujetos a cambio sin previo aviso			

Transferencias automáticas por contactores SIRIUS 3RT y contactores 3TF
Transferencias automáticas por interruptores Sentron
Transferencias automáticas por interruptores 3WN6



Mar.30/2000

No. Depósito	Descripción						Precio Lista Unit. - Bs (*)
<p>Transferencias automáticas por contactores SIRIUS 3RT y contactores 3TF Constan de dos contactores tripolares de la corriente indicada (bajo pedido pueden combinarse corrientes diferentes) montados sobre lámina metálica¹⁾ y enclavados mecánicamente. El circuito de control permite una transferencia manual o automática, elegible a voluntad mediante un selector, vigilancia de tensión (incluyendo caída de fase), indicadores luminosos para el estado de conexión, protección del control mediante fusibles y contacto para encendido de planta. El grupo electrógeno debe tener arranque automático.</p>							
	Tipo	I (A)	kVA		kW (Cos φ = 0.8)		
		AC1	220V	440V	220V	440V	
SIRIUS 943030	TA - 3R/15	18	6.8	13.2	5.5	11	
SIRIUS 943032	TA - 3R/24	40	15.2	30	12	24	Precios
SIRIUS 943044	TA - 3R/35	60	22	45	18	36	bajo
SIRIUS 943047	TA - 3R/44	100	38	76	30	60	consulta
SIRIUS 943048	TA - 3R/45	120	45	90	36	72	
943050	TA - 3T/50	170	64	128	51	102	
943052	TA - 3T/52	230	87	174	70	140	
943054	TA - 3T/54	325	123	246	98	196	Precios
943056	TA - 3T/56	425	162	324	130	260	bajo
943057	TA - 3T/57	600	228	457	182	365	consulta
943068	TA - 3T/68	700	267	534	214	428	
943069	TA - 3T/69	910	347	694	278	556	
<p>Transferencias automáticas por interruptores SENTRON Constan de dos interruptores de la corriente indicada (con accionamiento motorizado y bobina de mínima tensión) montados sobre lámina metálica¹⁾ y enclavados mecánicamente. El circuito de control permite una transferencia manual o automática, elegible a voluntad mediante un selector, vigilancia de tensión (incluyendo caída de fase), indicadores luminosos para el estado de conexión, protección del control mediante fusibles y contacto para encendido de planta. El grupo electrógeno debe tener arranque automático.</p>							
943140	TA - FX/125	125	48	96	38	76	
943141	TA - FX/150	150	57	114	46	92	
943142	TA - FX/175	175	67	134	54	108	
943143	TA - FX/200	200	76	152	61	122	
943144	TA - FX/225	225	86	172	69	138	Precios
943145	TA - FX/250	250	95	190	76	152	bajo
943146	TA - JX/300	300	114	228	91	182	consulta
943147	TA - JX/350	350	133	266	106	212	
943148	TA - JX/400	400	152	304	122	244	
943149	TA - LX/500	500	190	380	152	304	
943150	TA - LX/600	600	229	458	183	366	
943152	TA - LMX/800	800	305	610	244	488	
943153	TA - NX/1000	1000	381	762	305	609	Precios
943154	TA - NX/1200	1200	457	914	365	731	bajo
943155	TA - PX/1400	1400	533	1067	426	853	consulta
943156	TA - PX/1600	1600	609	1219	487	975	
943157	TA - RX/1800	1800	685	1371	584	1097	
943158	TA - RX/2000	2000	762	1524	609	1219	
<p>Notas: ¹⁾ Para precios de celdas y cajas metálicas, ver página 3/30. (*) El precio lista no incluye el IVA vigente.</p>							
<p>Página nueva Precios sujetos a cambio sin previo aviso</p>							

Transferencias automáticas por interruptores 3WN6

Mar.30/2000

No. Depósito	Descripción						Precio Lista Unit. - Bs (*)
	<p>Transferencias automáticas por interruptores 3WN6 Constan de dos interruptores de la corriente indicada (con accionamiento motorizado y bobina de mínima tensión) montados en celda autoportada y enclavados mecánicamente. El circuito de control permite una transferencia manual o automática, elegible a voluntad mediante un selector, vigilancia de tensión (incluyendo caída de fase), indicadores luminosos para el estado de conexión, protección del control mediante fusibles y contacto para encendido de planta. El grupo electrógeno debe tener arranque automático.</p>						
	Tipo	I (A) AC1	kVA		kW (Cos φ = 0.8)		
			220V	440V	220V	440V	
943222	TA - 3W/800	320-800	305	610	244	488	
943223	TA - 3W/1000	400-1000	381	762	305	610	
943224	TA - 3W/1250	500-1250	476	952	381	762	Precios
943225	TA - 3W/1600	640-1600	610	1220	488	976	bajo
943226	TA - 3W/2000	800-2000	762	1524	610	1220	consulta
943227	TA - 3W/2500	1000-2500	953	1906	762	1524	
943228	TA - 3W/3200	1280-3200	1220	2440	976	1952	
	<p>Notas: Para transferencia TA - 3T/68 y TA - 3T/69, favor consultar. (*) El precio lista no incluye el IVA vigente.</p>						
<p>Página nueva Precios sujetos a cambio sin previo aviso</p>							

Integradores

Caracas

ALS Automatismo Industrial, C.A.
Calle Guaicamacuto, Edif. Tony, Piso 1, Of. 12, El Marqués
☎ (02) 2431575 - 2433250
☎ (02) 2431575 - 2433250
Ing. Eduardo Cortés /
Ing. Leonardo Rodríguez

Ingeniería de Instrumentación y Automatización, Ingeniería M.F., C.A.
Edif. Guarimba, Piso 4, Of. 4-C, Avenida Francisco de Miranda. Los Dos Caminos.
☎ (02) 2382132 - 2387119
☎ (02) 2381497
Ing. Alfonso Mateo

Venecontrol, C.A.
Centro Empresarial Don Bosco, Los Cortijos de Lourdes, Caracas.
☎ (02) 2354429 - 2391327

Valencia - Maracay

Aprotedi, S.A.
Centro Comercial Arpe, Nave "D", Local 5, Avenida Pancho Pepe Croquer, Valencia.
☎ (041) 327161
☎ (041) 327161
Ing. Luís Guerra

Electrotécnica Imo, C.A.
Urb. Michelena, Calle Uslar frente Colgate Palmolive, Local 4, Valencia.
☎ (041) 580723 - 583393
☎ (041) 580723
E-mail: online@cantv.net
Ing. Rainier Salcedo

Pagsys, C.A.
Prolongación Avenida Michelena, Local No.4, Mezzanine, Valencia, Edo. Carabobo.
☎ (041) 326632 - 328520
☎ (041) 328520
Cel: 014 341 5342
Ing. Pedro Girón

Simatex, C.A.
Avenida Constitución, C.C. Los Mangos, Local 60, Planta Baja, Maracay, Edo. Aragua.
☎ (043) 463985
☎ (043) 461844
Ing. Américo Montilla

Maracaibo

Suplibarca
Avenida La Limpia, C.C. Carmen, Local 1-2, No.85-39, Maracaibo.
☎ (061) 555667 - 548761
☎ (061) 532259
Ing. Guillermo Barrera



Product Data

09AW,AZ001-020 Air-Cooled Condensers

1 to 20 Nominal Tons

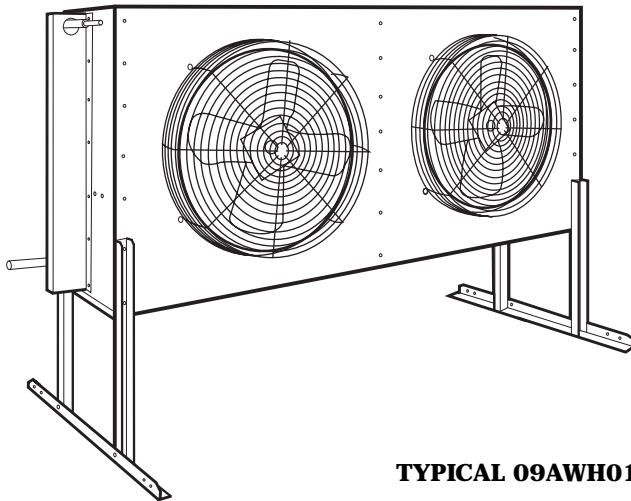

TYPICAL 09AWH012 UNIT

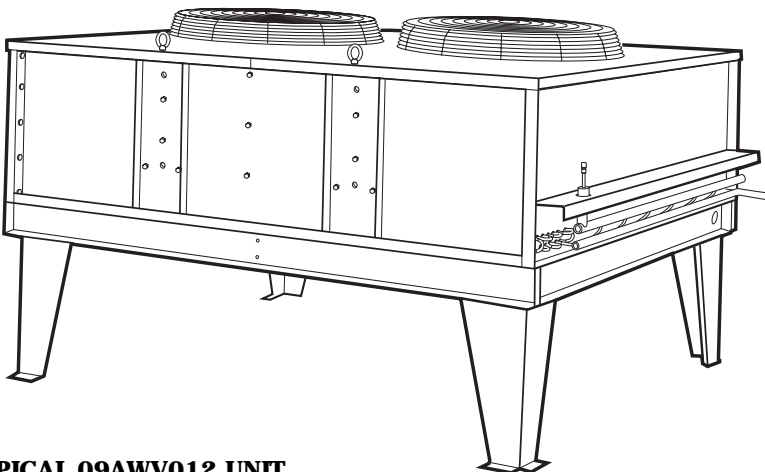

TYPICAL 09AWV012 UNIT

Air-Cooled Condensers for Remote System Application. Eleven sizes to choose from with:

- standard or low sound motor
- Proven performance in every building application
- Efficient direct-drive fans
- Cabinet designs in vertical and horizontal airflow configurations to meet a variety of application requirements
- Small compact footprints for installation in tight spaces
- A choice of factory-installed options that allow application customizing
- High-efficiency performance for commercial and industrial projects

Features/Benefits

A family of ruggedly built condensers ideal for clinics, motels, schools, apartment and office buildings, and factories.

Design flexibility

Carrier remote condensers provide the design flexibility required in replacement, renovation, and new construction. Units are available in 11 sizes from 1 to 20 tons. These condensers meet the needs for cooling restaurants, retail stores, warehouses, offices, and building additions.

Flexibility in meeting job requirements is ensured with unit design and available factory options. The compact footprint saves valuable space and allows installation in tight locations. Matching condensers to existing indoor units is easy with a selection of coil circuiting. These units can be installed in vertical or horizontal



airflow configurations allowing greater flexibility to meet job requirements. Units may also be used with several different refrigerants. Units are available in all popular single or three phase voltages and with factory-mounted control options.

Easy installation and maintenance

Units are completely pre-piped and wired at the factory to ensure time and money saving installation and service. Access panels are easily removed to provide speedy inspection and service of internal components. Factory-installed electrical junction box provides space for control connections. With factory-installed control options, such as head pressure control and factory circuiting, the unit arrives at the jobsite ready for installation. This reduces field labor. Mounting legs, shipped with the unit, are provided for all sizes. Precision engineered parts translate to a quality built, reliable design that will operate efficiently, minimize service calls, and provide years of reliable operation.

Quieter, more efficient operation

High efficiency direct-drive condenser fans with bell mouthed orifices provide large quantities of condenser air at low sound levels. Optional unit with lower-speed motor allows even quieter operation when necessary to meet local sound requirements.

Special features for outstanding performance

- Space saver slab type condenser coils use Carrier’s advanced heat transfer technology and provide peak heat transfer efficiency with large coil face area. Fins are mechanically bonded to nonferrous seamless tubing for efficient leak-free operation.
- Quiet fan performance efficiently moves large volumes of outdoor air. Specially designed discharge and fan sections provide superior air handling capability with high efficiency and low sound.
- Convenient access electrical control center contains all factory pre-wired control devices.

- The weather-resistant cabinets are constructed of galvanized steel and are capable of withstanding Federal test method Standard No. 141 (Method 6061) 500-hour salt spray test.
- A choice of motor controls provides the flexibility to meet most application requirements.
- The 09AW,AZ units are fully warranted as shipped from the factory, including 1 year on all parts.
- All motors are protected against thermal overload and 3-phase motors are protected against single-phasing conditions.
- The 09AZ units are specifically customized with options required for use with the 50BZ indoor units. This includes appropriate circuiting with subcooling, condenser-fan contactors, and optimized coil surface.

Table of contents

	Page
Features/Benefits	1,2
Model Number Nomenclature	3,4
ARI Capacities	5
Physical Data	6,7
Factory-Installed Options	8
Field-Installed Accessories	8
Base Unit Dimensions	9-16
Selection Procedure	17
Performance Data	18-22
Typical Wiring Schematic	23
Typical Piping and Wiring	24
Electrical Data	25
Controls	26
Application Data	27-29
Guide Specifications	30-32

Model number nomenclature



09 AW H 012 V E - 6 0 1 A

09 – Remote
Air-Cooled
Condenser

AW – Direct-Drive
General Purpose

Configuration

H – Horizontal, Standard Motor
V – Vertical, Standard Motor*
L – Horizontal, Low Sound Motor
W – Vertical, Low Sound Motor*

Nominal Heat Rejection

Size	Tons	Size	Tons
001	– 1	012	– 10
002	– 2	014	– 12
003	– 3	016	– 15
004	– 4	018	– 17
006	– 5	020	– 20
008	– 7-1/2		

Motor Control Option

- – Open Drip Proof (ODP)
C – Contactors, ODP
F – Fan Cycling, ODP†
V – Speed Control, ODP**
T – Totally Enclosed, Air Over Motor (TEAO)
E – Contactors, TEAO
D – Fan Cycling, TEAO†
W – Speed Control, TEAO**

Circuiting Option

- – Single Circuit, No Subcooling
A – Single Circuit with Subcooling
D – Two Circuit, No Subcooling
E – Two Circuit with Subcooling

Factory Options

A – Aluminum Cabinet
B – Fused Disconnect††
C – 24 Volt Transformer
D – Aluminum Cabinet, Fused Disconnect††
E – Aluminum Cabinet, 24 Volt Transformer
F – Fused Disconnect, 24 Volt Transformer
G – Aluminum Cabinet, Fused Disconnect,
24 Volt Transformer††

Packaging

1 – Standard

Design Series

0 – First Design

V-Ph-Hz

1 – 575-3-60 (sizes 014-020) or
575-1-60 (sizes 001-012)
3 – 208/230-1-60
5 – 208/230-3-60
6 – 460-3-60

Coil Construction Option

- – Aluminum Fin/Copper Tube
C – Copper Fin/Copper Tube
E – Polyester Coated Aluminum Fin/Copper Tube
X – Phenolic Coated Aluminum Fin/Copper Tube
Z – Phenolic Coated Copper Fin/Copper Tube

*Sizes 014-020 only. Sizes 001 to 012 may be mounted standard as vertical or horizontal.

†Fan cycling includes contactors.

**Speed control includes contactors on all units and fan cycling on 006 to 020 unit sizes.

††Fused disconnect available on 3-phase units only.

Model number nomenclature (cont)



09 AZ H 012 V - - 3 0 1 A

09 – Remote
Air-Cooled
Condenser

AZ – Direct-Drive
(Sized to Work Best with 50BZ)

Configuration

H – Horizontal, Standard Motor
V – Vertical, Standard Motor*
L – Horizontal, Low Sound Motor
W – Vertical, Low Sound Motor*

Nominal Heat Rejection

Size	Tons	Size	Tons
006	– 5	014	– 12
008	– 7-1/2	016	– 15
012	– 10		

Motor Control Option

- – Open Drip Proof (ODP) with Contactors
F – Fan Cycling, ODP
V – Speed Control, ODP**
T – Totally Enclosed, Air Over Motor (TEAO)
with Contactors
D – Fan Cycling, TEAO
W – Speed Control, TEAO**

Circuiting Option

- – Single Circuit or Two Circuit
with Subcooling†

Factory Options

A – Aluminum Cabinet
B – Fused Disconnect††
D – Aluminum Cabinet, Fused Disconnect††
F – Fused Disconnect, 24 Volt Transformer††

Packaging

1 – Standard

Design Series

0 – First Design

V-Ph-Hz

1 – 575-3-60 (sizes 012-016) or
575-1-60 (sizes 006-008)
3 – 208/230-1-60
5 – 208/230-3-60
6 – 460-3-60

Coil Construction Option

- – Aluminum Fin/Copper Tube
C – Copper Fin/Copper Tube
E – Polyester Coated Aluminum Fin/Copper Tube
X – Phenolic Coated Aluminum Fin/Copper Tube
Z – Phenolic Coated Copper Fin/Copper Tube

*Sizes 012-016 only. Sizes 006 and 008 are standard for vertical or horizontal airflow.

†As required with 50BZ of the same tonnage size.

**Fan cycling included with speed control on 008 to 016 size units.

††Fused disconnect available on 3-phase units only.

ARI* capacities



UNIT 09		NOMINAL TONS	OUTDOOR Cfm	HEAT REJECTION (Btuh)	TOTAL kW
AWH, AWV	001	1	3,100	20,200	0.46
	002	2	2,750	34,300	0.46
	003	3	3,850	55,400	0.46
	004	4	3,700	72,500	0.46
	006	5	7,700	110,500	0.92
	008	7½	7,400	145,000	0.92
	012	10	7,000	166,000	0.92
	014	12	15,700	217,300	1.84
	016	15	15,600	243,000	1.84
	018	17	15,400	290,000	1.84
020	20	15,300	318,000	1.84	
AWL, AWW	001	1	2,540	19,100	0.28
	002	2	2,040	30,000	0.28
	003	3	2,850	47,000	0.28
	004	4	2,740	60,500	0.28
	006	5	5,700	93,700	0.55
	008	7½	5,480	121,000	0.55
	012	10	5,110	133,000	0.55
	014	12	11,600	190,000	1.00
	016	15	11,400	206,000	1.00
	018	17	11,500	246,000	1.00
020	20	11,300	265,000	1.00	
AZH, AZV	006	5	3,600	75,700	0.46
	008	7½	7,500	134,700	0.92
	012	10	15,260	166,000	1.84
	014	12	15,132	221,000	1.84
	016	15	14,872	256,000	1.84
AZL, AZW	006	5	6,400	76,600	0.55
	008	7½	5,300	112,000	0.55
	012	10	11,070	180,000	1.00
	014	12	10,872	219,000	1.00
	016	15	10,566	254,000	1.00

*Air Conditioning and Refrigeration Institute.

NOTES:

1. A temperature difference of 30° F is required.
2. ARI rating condition with R-22 is 95 F air entering the condenser, 125 F saturated condensing temperature, charged to nominal system charge per installation instructions for 5° F of subcooling.

Physical data



UNIT	09AWH/AWW										
	001	002	003	004	006	008	012	014	016	018	020
RATING (Tons)	1	2	3	4	5	7½	10	12	15	17	20
OPERATING WEIGHT (lb)	109	121	144	160	234	259	283	524	537	581	597
SHIPPING WEIGHT (lb)	153	165	188	204	303	328	352	636	649	693	709
REFRIGERANT	R-22/R-134a (See Performance Data for Operating Charge)										
NOM HEAT REJECTION*	16.8	28.6	46.2	60.5	92.1	120.9	138.5	181.0	202.2	246.7	264.7
FAN	Direct Drive										
Quantity	1	1	1	1	2	2	2	2	2	2	2
Prop. Diameter (in.)	18	18	22	22	22	22	22	26	26	26	26
Blade Quantity	4	4	4	4	4	4	4	4	4	4	4
Rpm	1140	1140	1140	1140	1140	1140	1140	1140	1140	1140	1140
Total Airflow (cfm)	3100	2750	3850	3700	7700	7400	7000	15,700	15,600	15,400	15,300
Motor Hp (per fan)	½	½	½	½	½	½	½	1	1	1	1
COIL	Cu Tube/Al Fin or Cu Tube/Cu Fin or Cu Tube with Coated Fin										
Arrangement	May be mounted Vertical/Horizontal†					Factory ordered Vertical or Horizontal**					
Rows	1	2	2	3	2	3	4	2	2	3	3
Fins/in.	8	8	10	10	10	10	10	8	10	8	10
Total Face Area (sq ft)	4.34	4.34	6.25	6.25	12.5	12.5	12.5	30.1	30.1	30.1	30.1
Number of Circuits	1	1 or 2									
Subcooler	Optional										
CONNECTIONS (in.)											
In, 1 Circuit	5/8	7/8	7/8	1 1/8	1 1/8	1 3/8	1 3/8	1 3/8	1 5/8	1 5/8	1 3/8
Out, 1 Circuit	5/8	5/8	5/8	7/8	7/8	1 1/8	1 1/8	1 1/8	1 3/8	1 3/8	1 1/8
In, 2 Circuit	N/A	5/8	7/8	7/8	7/8	7/8	1 1/8	1 1/8	1 1/8	1 1/8	1 3/8
Out, 2 Circuit	N/A	5/8	5/8	5/8	5/8	5/8	7/8	7/8	7/8	7/8	1 1/8

UNIT	09AWL/AWW										
	001	002	003	004	006	008	012	014	016	018	020
RATING (Tons)	1	2	3	4	5	7½	10	12	15	17	20
OPERATING WEIGHT (lb)	109	121	144	160	234	259	283	524	537	581	597
SHIPPING WEIGHT (lb)	153	165	188	204	303	328	352	636	649	693	709
REFRIGERANT	R-22/R-134a (See Performance Data for Operating Charge)										
NOM HEAT REJECTION*	15.9	25.0	39.2	50.4	78.1	100.9	111.1	158.3	171.5	205.2	221.0
FAN	Direct Drive										
Quantity	1	1	1	1	2	2	2	2	2	2	2
Prop. Diameter (in.)	18	18	22	22	22	22	22	26	26	26	26
Blade Quantity	4	4	4	4	4	4	4	4	4	4	4
Rpm	850	850	850	850	850	850	850	850	850	850	850
Total Airflow (cfm)	2540	2040	2850	2740	5700	5480	5110	11,600	11,400	11,500	11,300
Motor Hp (per fan)	¼	¼	¼	¼	¼	¼	¼	½	½	½	½
COIL	Cu Tube/Al Fin or Cu Tube/Cu Fin or Cu Tube with Coated Fin										
Arrangement	May be mounted Vertical/Horizontal†					Factory ordered Vertical or Horizontal**					
Rows	1	2	2	3	2	3	4	2	2	3	3
Fins/in.	8	8	10	10	10	10	10	8	10	8	10
Total Face Area (sq ft)	4.34	4.34	6.25	6.25	12.5	12.5	12.5	30.1	30.1	30.1	30.1
Number of Circuits	1	1 or 2									
Subcooler	Optional										
CONNECTIONS (in.)											
In, 1 Circuit	5/8	7/8	7/8	1 1/8	1 1/8	1 3/8	1 3/8	1 3/8	1 5/8	1 5/8	1 3/8
Out, 1 Circuit	5/8	5/8	5/8	7/8	7/8	1 1/8	1 1/8	1 1/8	1 3/8	1 3/8	1 1/8
In, 2 Circuit	N/A	5/8	7/8	7/8	7/8	7/8	1 1/8	1 1/8	1 1/8	1 1/8	1 3/8
Out, 2 Circuit	N/A	5/8	5/8	5/8	5/8	5/8	7/8	7/8	7/8	7/8	1 1/8

*Heat rejection is based on 25 F temperature difference from saturated discharge temperature to entering-air temperature.

†Units may be mounted vertically or horizontally.

**Unit is factory ordered for vertical or horizontal discharge.



UNIT	09AZH/09AZV					09AZL/09AZW				
	006*	008*	012	014	016	006*	008*	012	014	016
RATING (Tons)	5	7½	10	12	15	5	7½	10	12	15
OPERATING WEIGHT (lb)	160	259	524	537	537	234	259	537	581	597
SHIPPING WEIGHT (lb)	204	328	636	649	649	303	328	649	693	709
REFRIGERANT	R-22/R-134a (See Performance Data for Operating Charge)									
NOM HEAT REJECTION†	75.8	111.5	152.6	184.1	213.4	76.6	112.0	150.2	182.2	211.6
FAN	Direct Drive									
Quantity	1	2	2	2	2	2	2	2	2	2
Prop. Diameter (in.)	22	22	26	26	26	22	22	26	26	26
Blade Quantity	4	4	4	4	4	4	4	4	4	4
Rpm	1140	1140	1140	1140	1140	850	850	850	850	850
Total Airflow (cfm)	3600	7500	15,260	15,132	14,872	6400	5300	11,070	10,872	10,566
Motor Hp (per fan)	½	½	1	1	1	¼	¼	½	½	½
COIL	Cu Tube/Al Fin or Cu Tube/Cu Fin or Cu Tube with Coated Fin									
Arrangement	**		††			**		††		
Rows	3	3	2	2	2	2	3	2	3	3
Fins/in.	14	12	8	10	14	10	14	10	8	12
Total Face Area (sq ft)	6.25	12.5	30.1	30.1	30.1	12.5	12.5	30.1	30.1	30.1
Number of Circuits	1		2			1		2		
Subcooler	Standard									
CONNECTIONS (in.)										
In, 1 Circuit	1⅛	1⅜	N/A	N/A	N/A	1⅛	1⅜	N/A	N/A	N/A
Out, 1 Circuit	7⁄8	1⅛	N/A	N/A	N/A	7⁄8	1⅛	N/A	N/A	N/A
In, 1 Circuit	N/A	N/A	1⅛	1⅛	1⅛	N/A	N/A	1⅛	1⅛	1⅛
Out, 2 Circuit	N/A	N/A	7⁄8	7⁄8	7⁄8	N/A	N/A	7⁄8	7⁄8	1⅛

*Not available on AZV and AZW.

†Heat rejection is based on 25 F temperature difference from saturated discharge temperature to entering-air temperature.

**Unit may be mounted vertically or horizontally.

††Unit is factory ordered for vertical or horizontal discharge.

Factory-installed options



Coil fin treatment options

Coils may be supplied with copper, polyester coated or phenolic fins, to provide optimum corrosion resistance in a variety of applications.

Circuiting options

Coils may be factory ordered for single or dual circuit applications. A last pass subcooling circuit can be provided if required by the application. The 09AZ units have circuiting to match same size 50BZ units and subcooler standard.

Motor option

Totally Enclosed, Air Over design motors may be used when required for harsh environments. Low sound fan motors can be provided for acoustically sensitive environments.

Motor control options

Factory-installed controls can provide 24-volt operated fan contactors, fan cycling control 2-fan units (include fan

contactor). Head pressure Control operation can be provided by factory-mounted pressure operated fan cycling control on 2-fan units or lead fan motor head pressure control for operational temperatures as low as -20 F.

Fused disconnect

Power circuit fused disconnect switch can be factory-mounted on 3-phase units.

Control transformer

Line voltage to 24 v 40 va control transformer is factory-mounted for control of condenser and indoor unit. (Not available on 09AZ units.)

Aluminum cabinet

Cabinet can be fabricated with embossed aluminum for a more attractive, corrosion-resistant cabinet finish.

Field-installed accessories

Mounting legs

30 in. extended legs are field installed.

Base unit dimensions



09AWH,AWL001-004 HORIZONTAL DISCHARGE

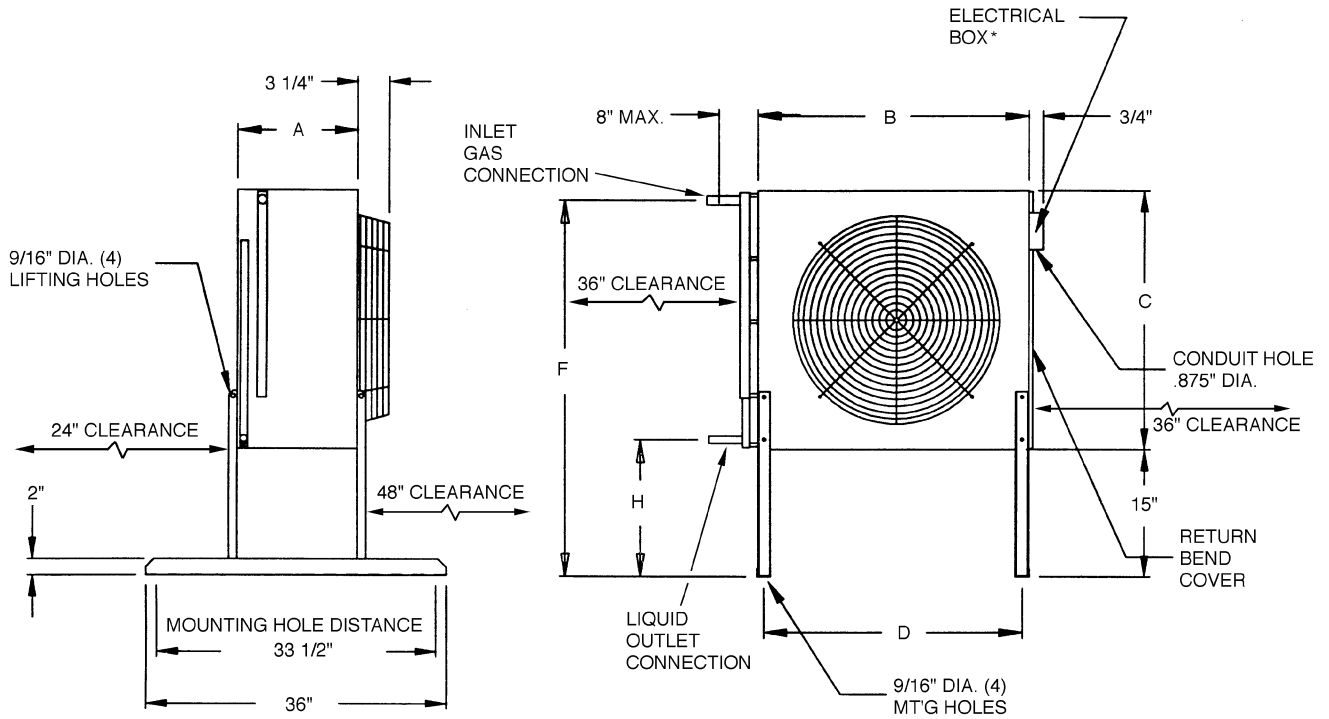

VERTICAL DISCHARGE

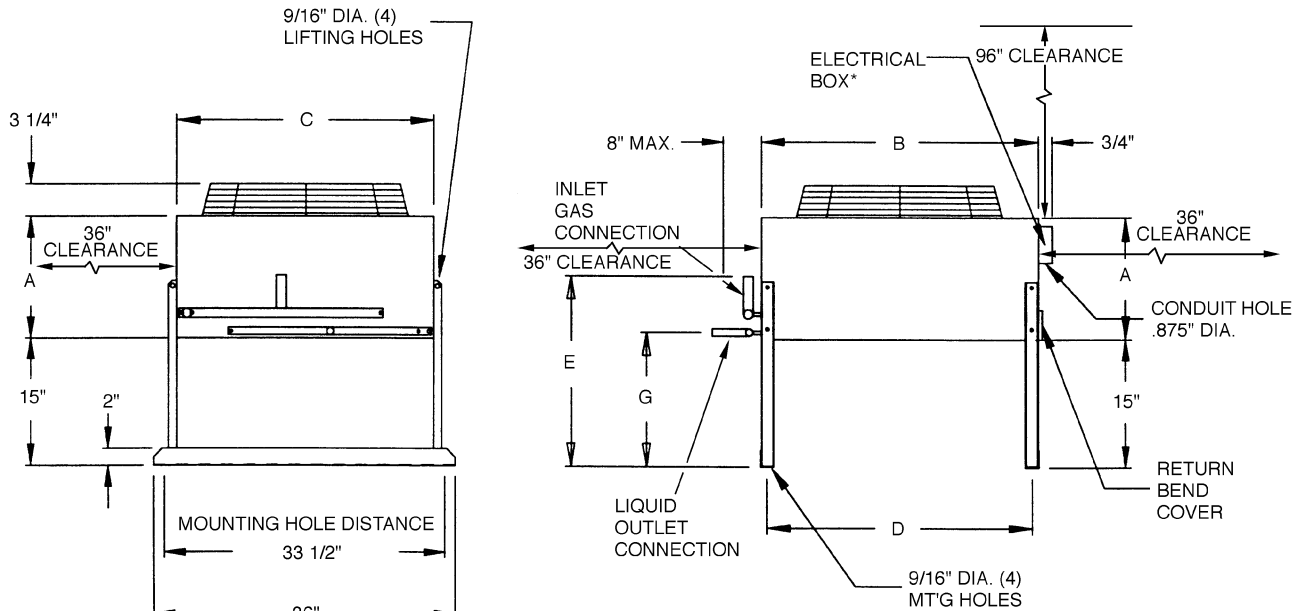

*Coil connection dimensions reflect single circuit units.
†Control box size varies depending on control options.

UNIT	FAN QUANTITY	TOTAL WEIGHT (lbs)	A (in.)	B (in.)	C (in.)	D (in.)	E (in.)	F (in.)	G (in.)	H (in.)	
09AWH, 09AWL	001	1	109	12.56	28	25.63	26.5	20.10	39.94	15.79	16.19
	002	1	121	12.56	28	25.63	26.5	22.08	27.50	15.09	16.63
	003	1	144	14.50	33	30.63	31.5	22.08	30.01	15.09	16.63
	004	1	160	14.50	33	30.63	31.5	23.35	44.25	15.79	16.75

Base unit dimensions (cont)



09AWH,AWL006,008,012 HORIZONTAL DISCHARGE

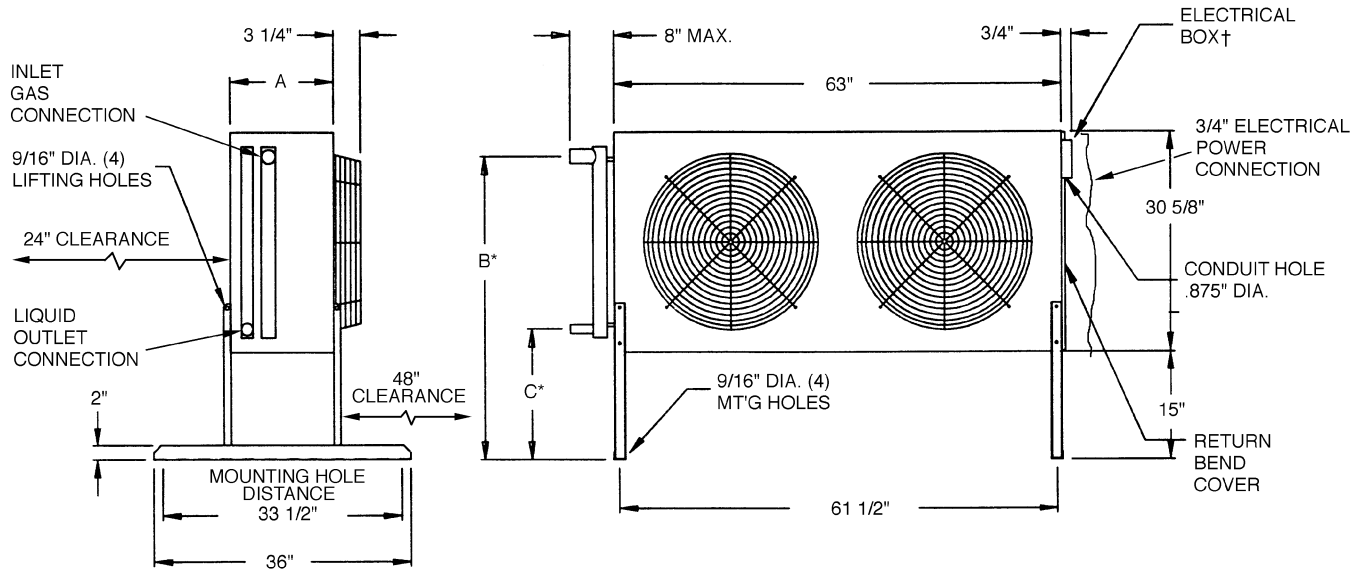

VERTICAL DISCHARGE

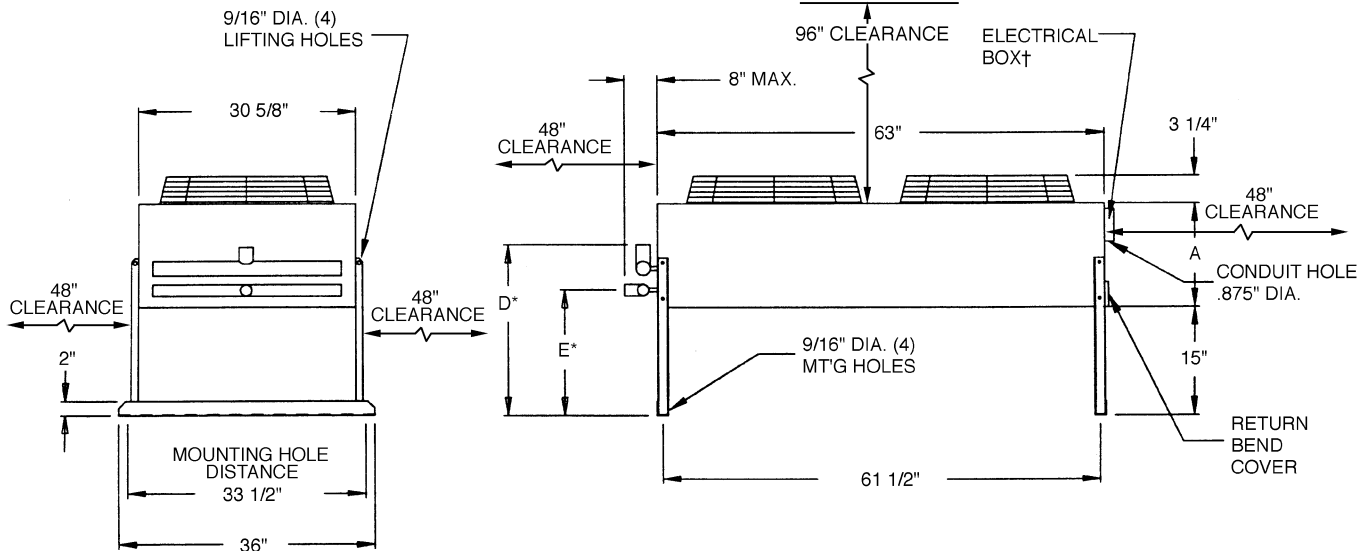

*Coil connection dimensions reflect single circuit units.
†Control box size varies depending on control options.

UNIT	FAN QUANTITY	TOTAL WEIGHT (lbs)	A (in.)	B (in.)	C (in.)	D (in.)	E (in.)	
09AWH, 09AWL	006	2	234	14.50	37.38	16.75	22.27	15.02
	008	2	259	14.50	44.13	16.88	23.54	15.79
	012	2	283	15.75	41.00	16.87	23.78	15.84

09AWH,AWL014-020
HORIZONTAL DISCHARGE

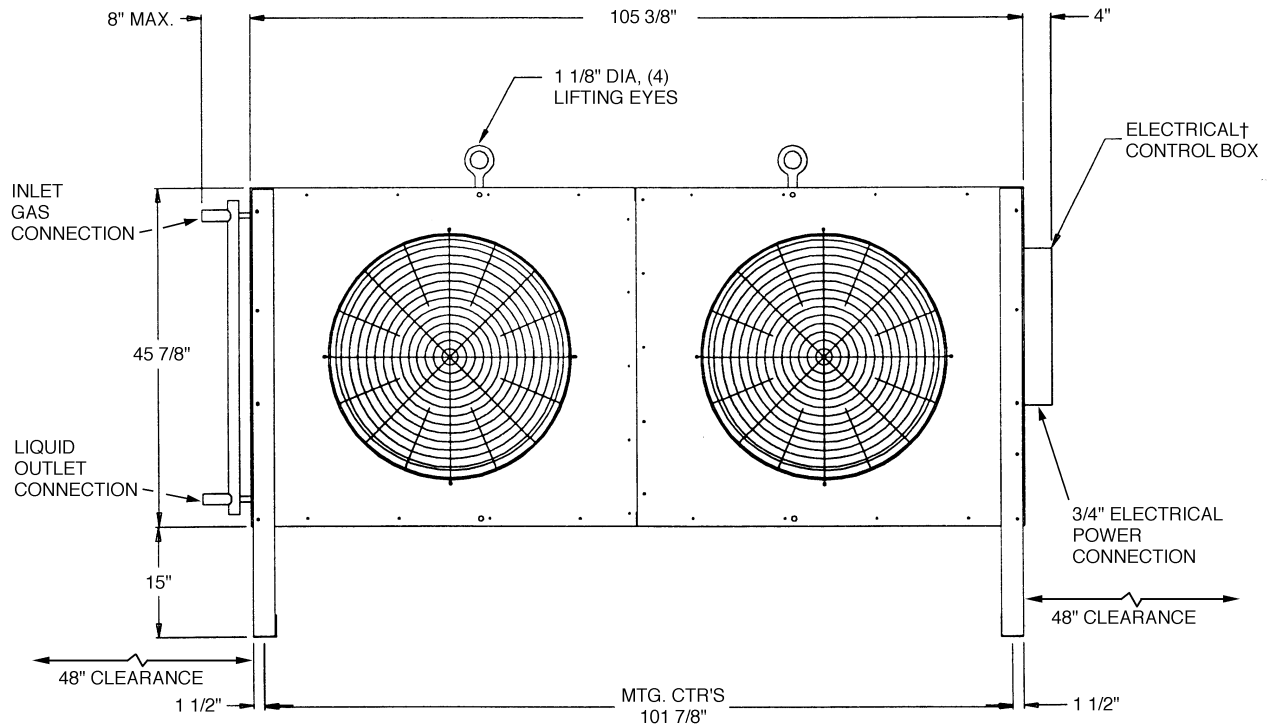
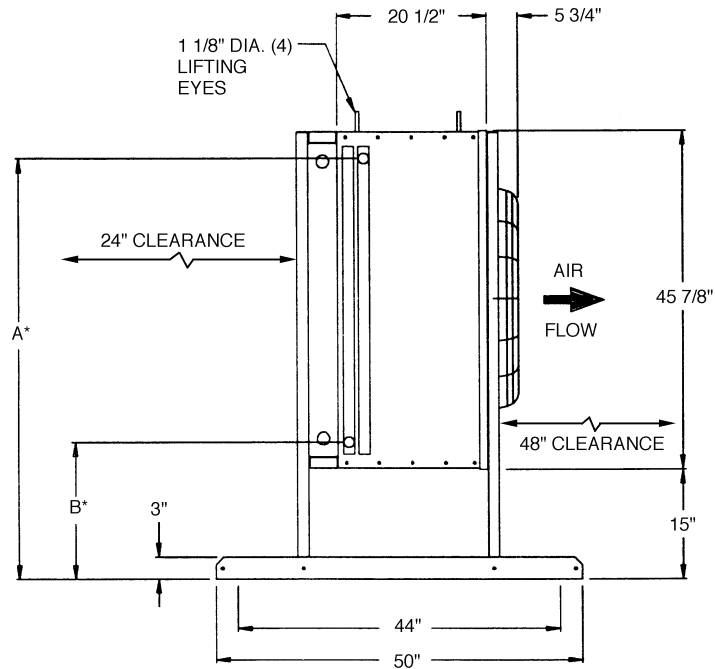

*Coil connection dimensions reflect single circuit units.
 †Control box size varies depending on control options.

UNIT	FAN QUANTITY	TOTAL WEIGHT (lbs)	A (in.)	B (in.)
09AWH, 09AWL	014	2	52.19	19.38
	016	2	52.06	19.50
	018	2	58.1	18.25
	020	2	59.7	18.13

Base unit dimensions (cont)



09AWV, AWW014-020

VERTICAL AIRFLOW

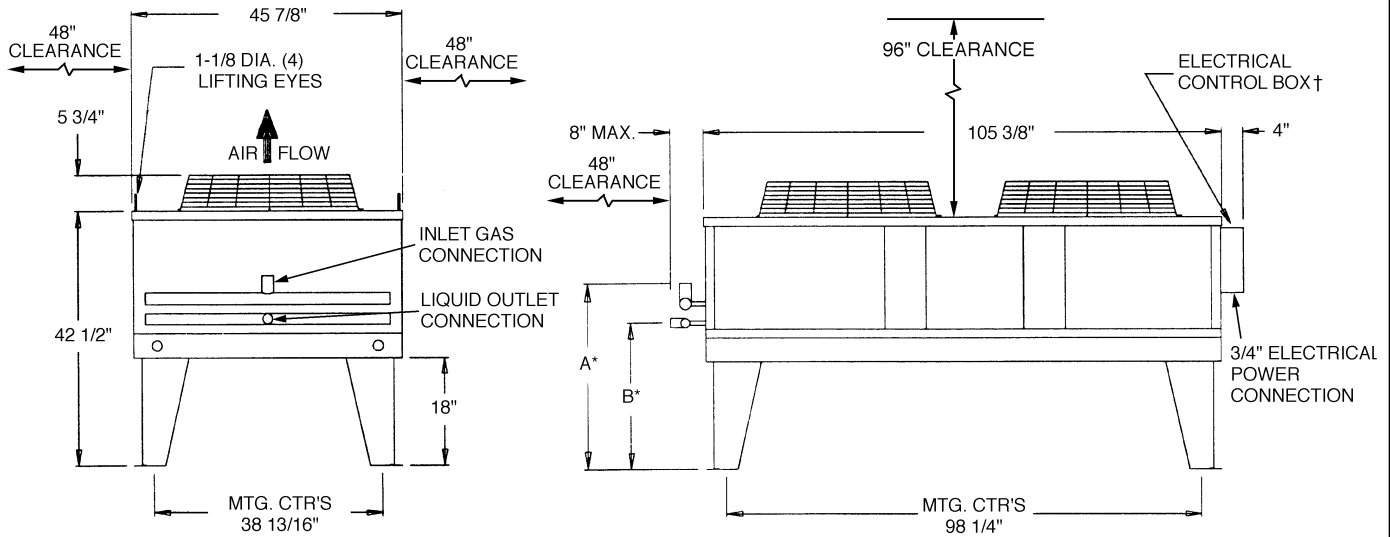

*Coil connection dimensions reflect single circuit units, header divided for 2 circuits.
 †Control box size varies depending on control options.

OPTIONAL 30" LEG DETAIL

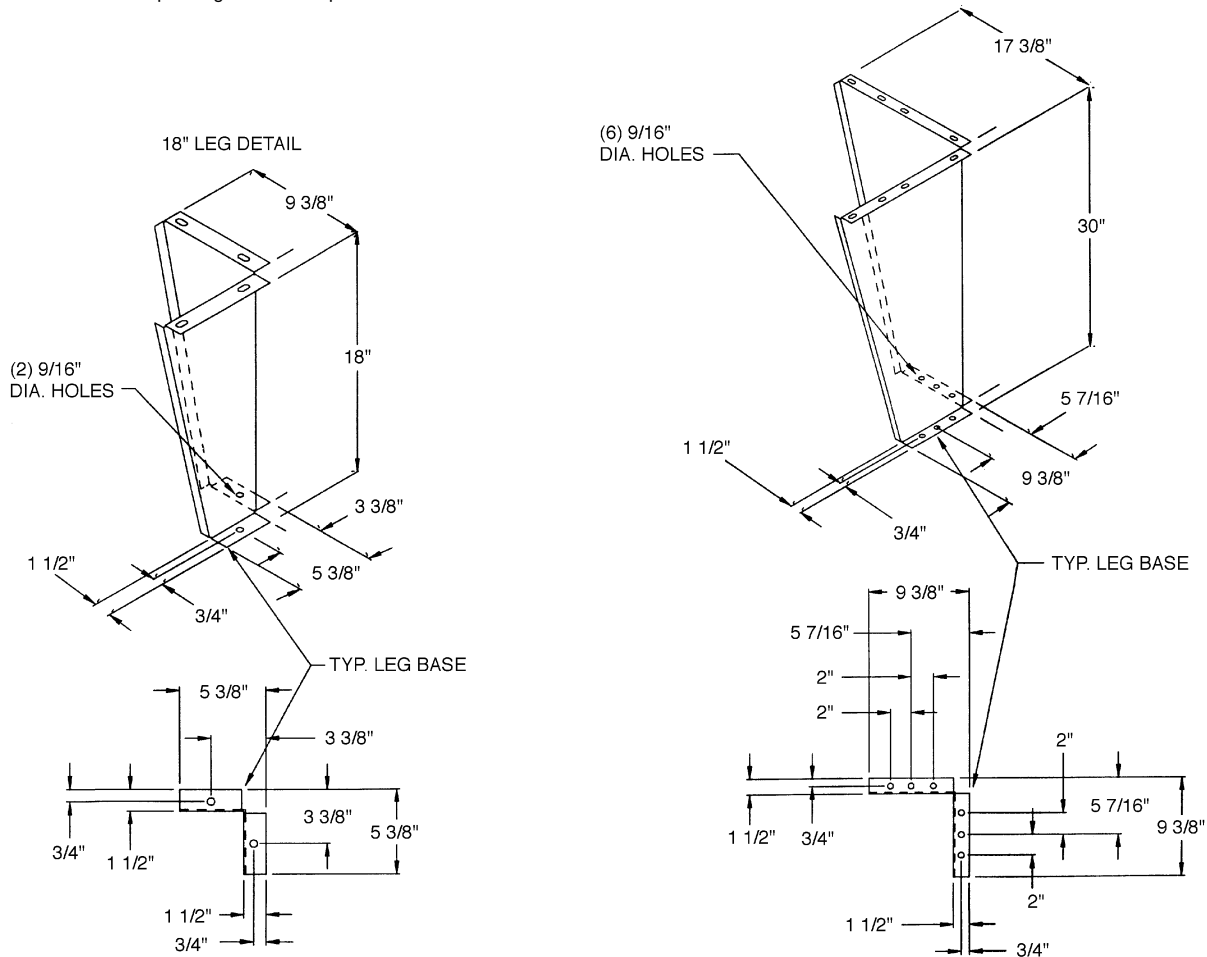

UNIT	FAN QUANTITY	TOTAL WEIGHT (lbs)	A (in.)	B (in.)
09AWV, AWW	014	2	30.22	22.73
	016	2	30.41	22.67
	018	2	30.49	23.56
	020	2	31.31	23.56

09AZH006
HORIZONTAL DISCHARGE

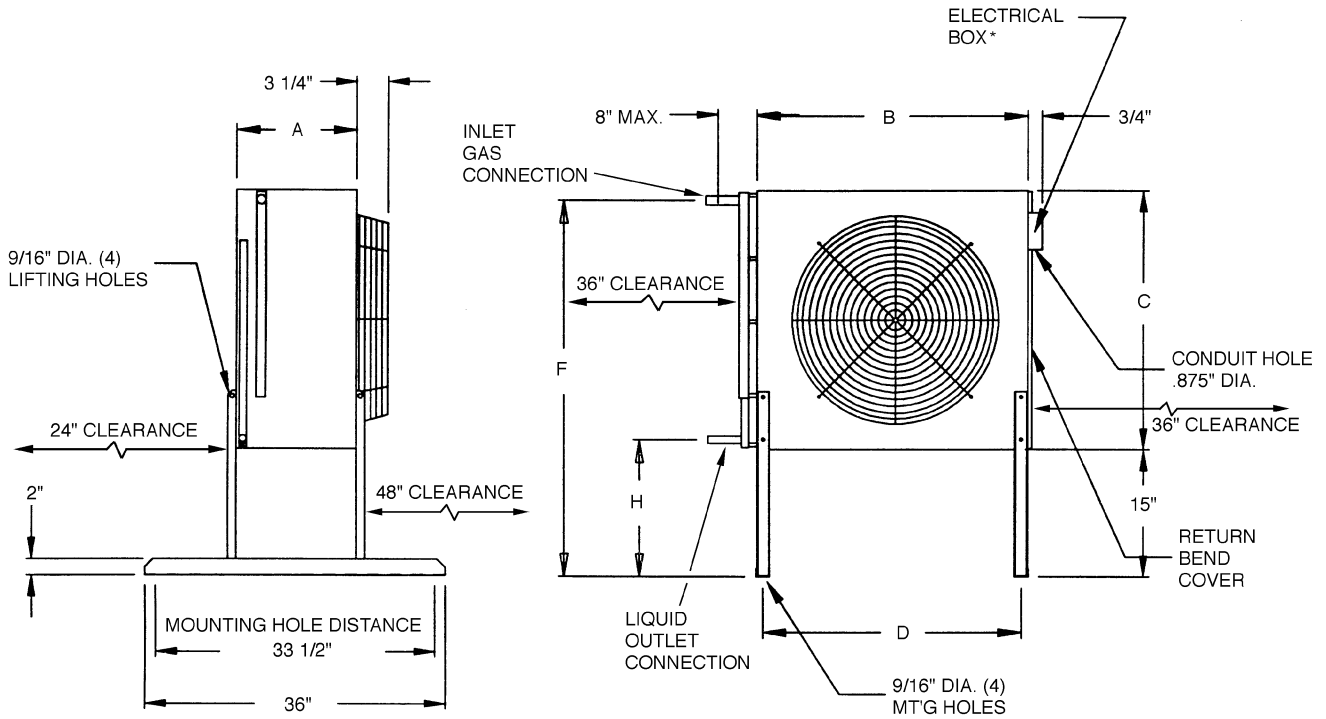

VERTICAL DISCHARGE

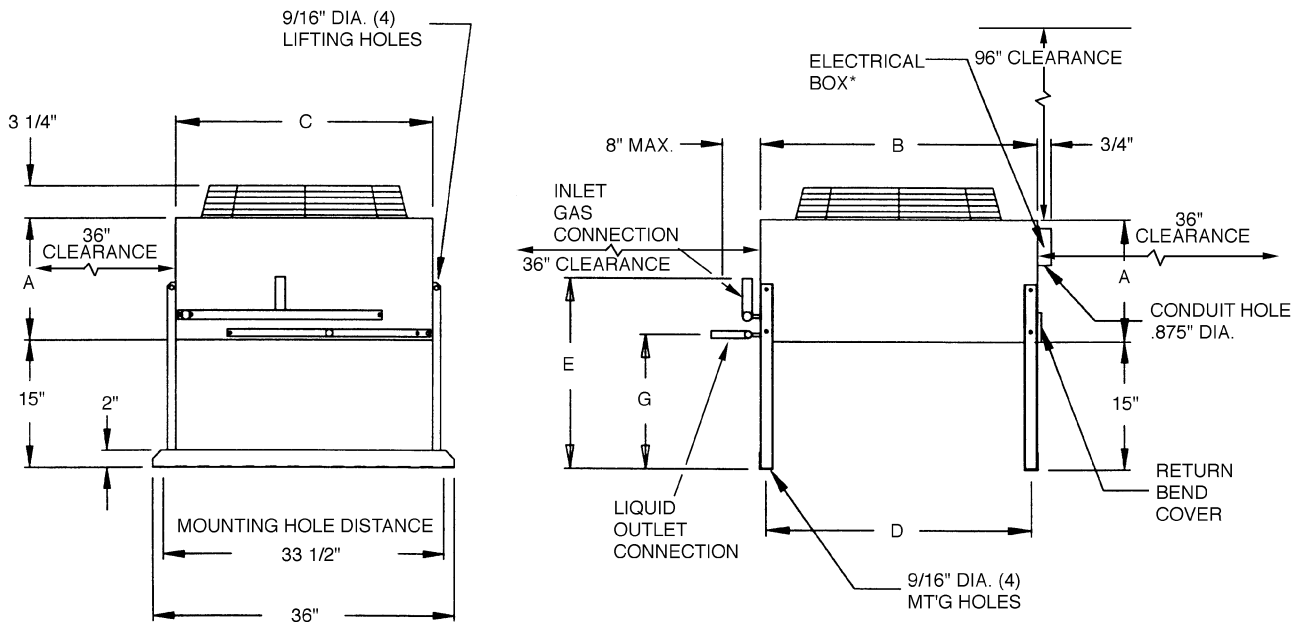

*Control box size varies depending on control options.

UNIT	FAN QUANTITY	TOTAL WEIGHT (lbs)	A (in.)	B (in.)	C (in.)	D (in.)	E (in.)	F (in.)	G (in.)	H (in.)
09AZH006	1	160	14.50	33	30.60	31.5	23.35	44.25	15.79	16.75

Base unit dimensions (cont)



09AZH008, 09AZL006,008 HORIZONTAL DISCHARGE

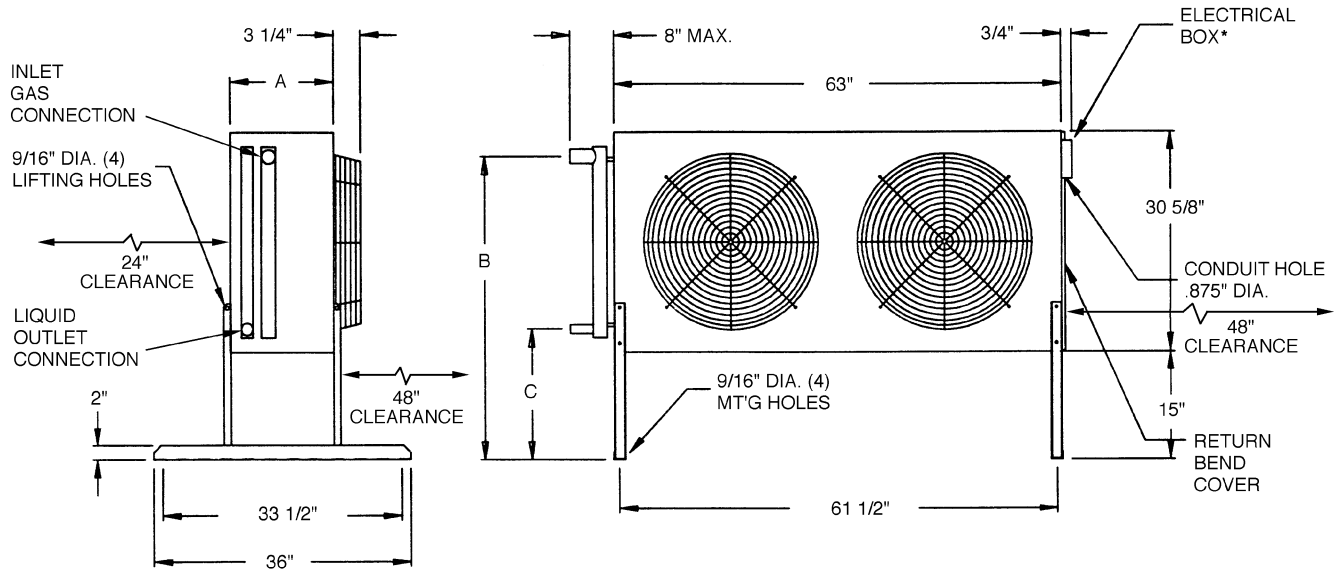

VERTICAL DISCHARGE

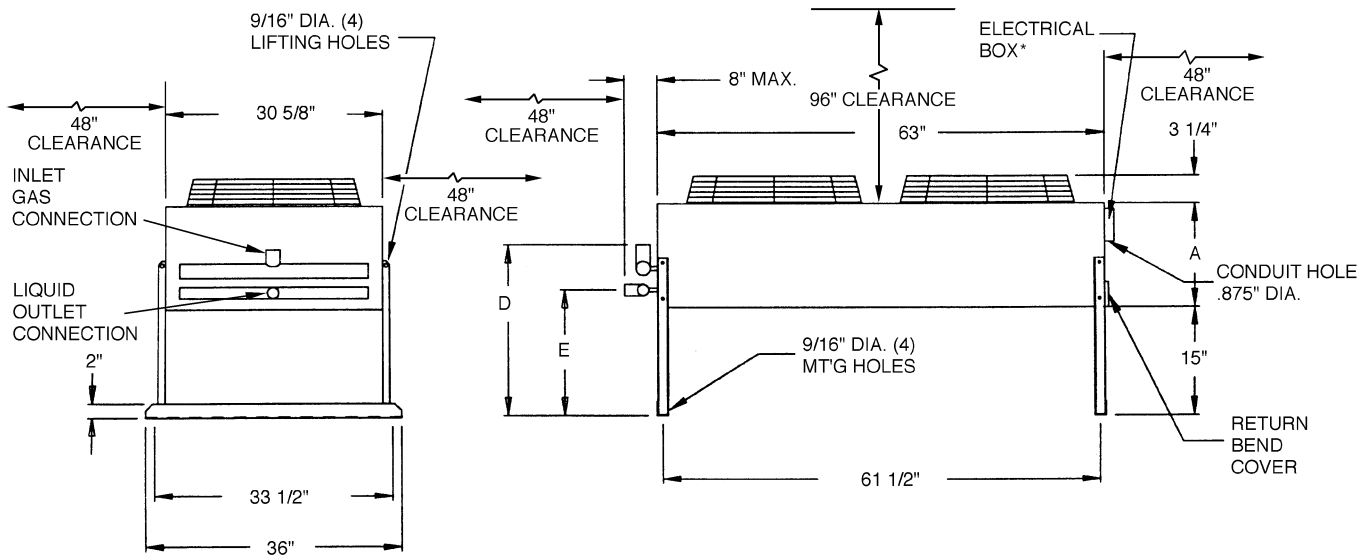

*Control box size varies depending on control options.

UNIT	FAN QUANTITY	TOTAL WEIGHT (lbs)	A (in.)	B (in.)	C (in.)	D (in.)	E (in.)
09AZH	008	259	14.50	44.13	16.88	23.54	15.79
09AZL	006	234	14.50	37.38	16.75	22.27	15.02
	008	259	14.50	44.13	16.88	23.54	15.79

09AZH,AZL012-016
HORIZONTAL DISCHARGE

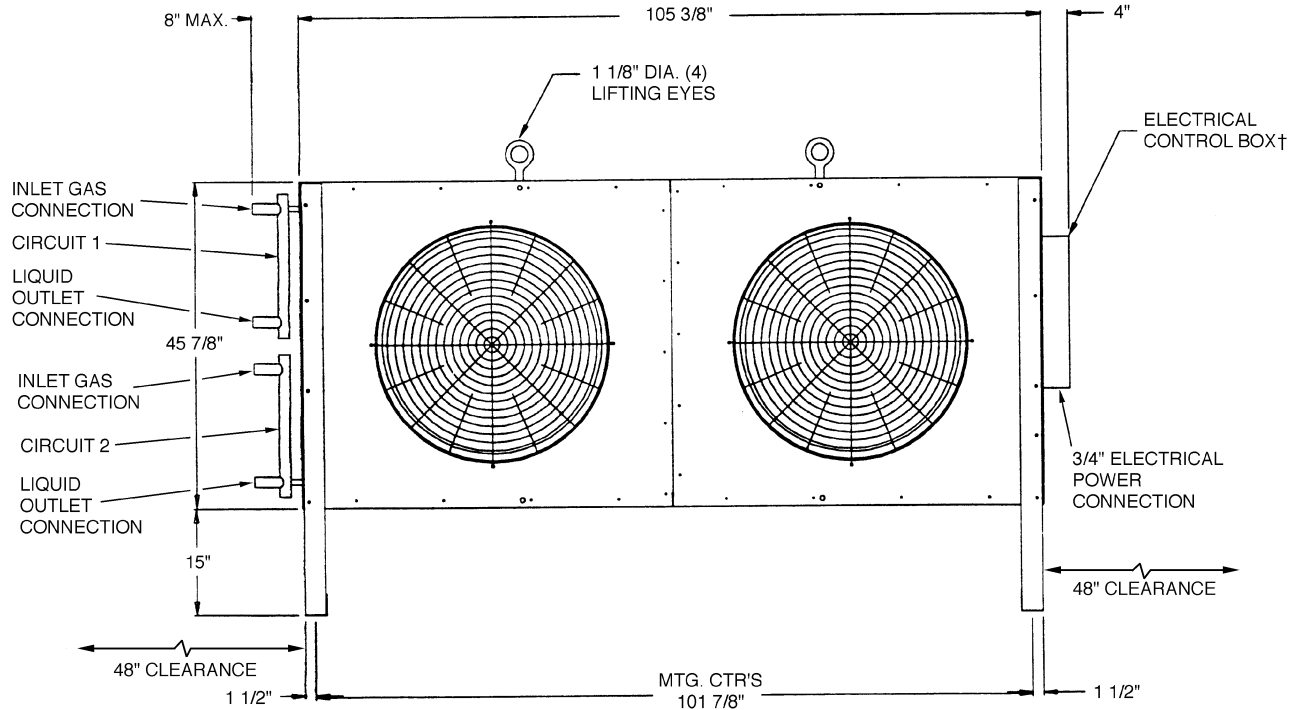
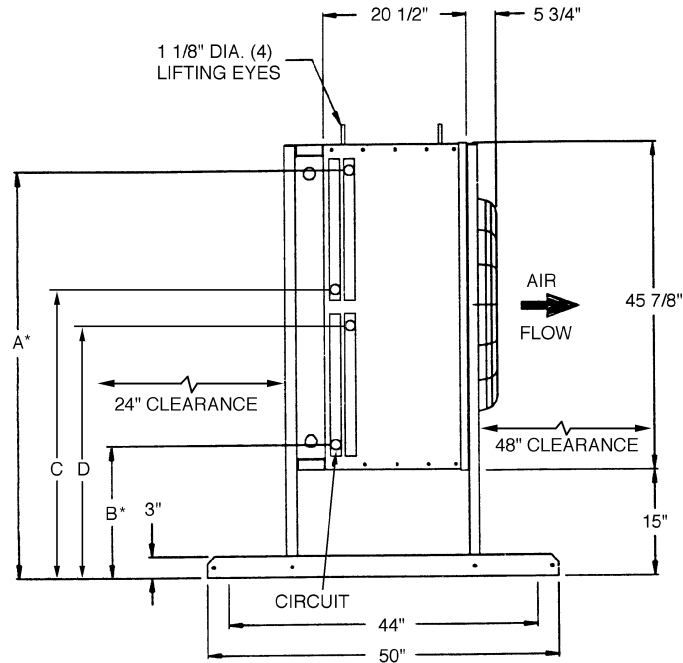

*Coil connection dimensions reflect dual circuit options.
†Control box size varies depending on control options.

UNIT	FAN QUANTITY	TOTAL WEIGHT (lbs)	A (in.)	B (in.)	C (in.)	D (in.)	
09AZH	012	2	524	52.19	19.38	37.80	33.80
	014	2	537	52.06	19.50	37.78	33.78
	016	2	537	52.06	19.50	37.78	33.78
09AZL	012	2	537	52.06	19.50	37.78	33.78
	014	2	581	56.50	18.25	39.40	35.37
	016	2	597	56.63	18.13	39.40	35.40

Base unit dimensions (cont)



09AZV, AZW012-016 VERTICAL AIRFLOW

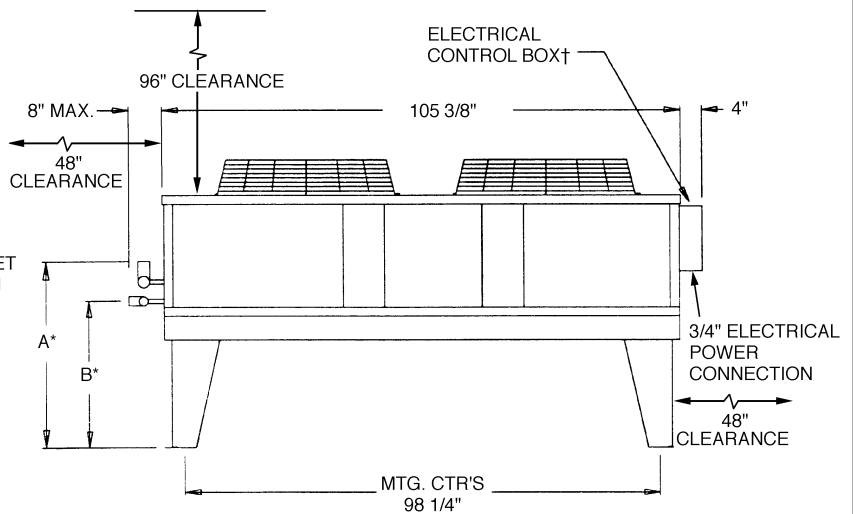
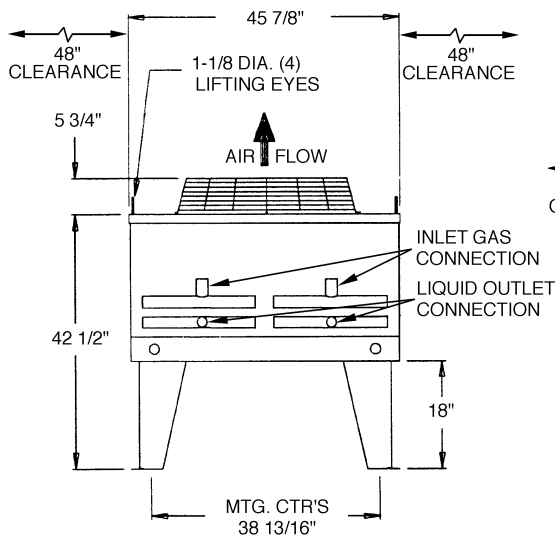

*Coil connections reflect single circuit units, header divided for 2 circuits.
†Control box size varies depending on control options.

OPTIONAL 30" LEG DETAIL

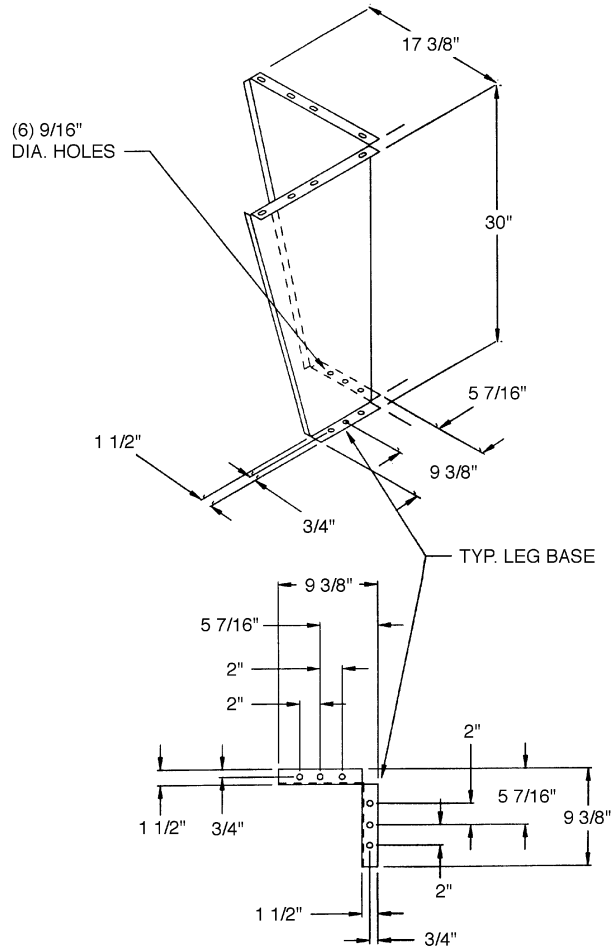
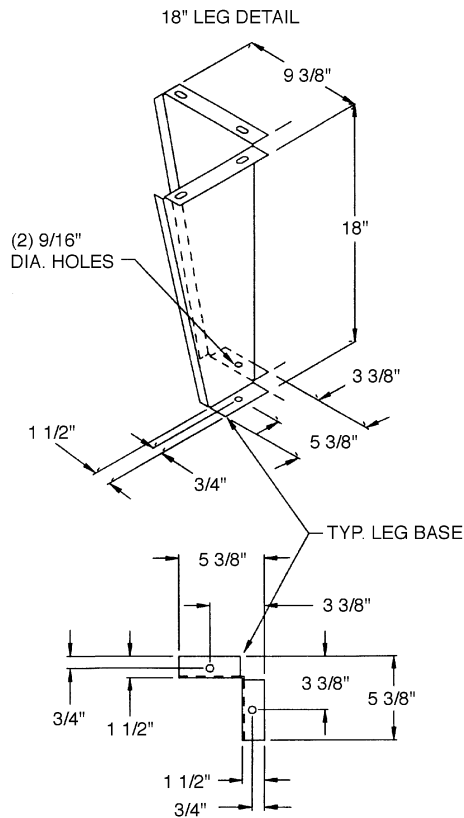

UNIT	FAN QUANTITY	TOTAL WEIGHT (lbs)	A (in.)	B (in.)	
09AZV	012	2	524	30.22	22.73
	014	2	537	30.41	22.67
	016	2	537	30.41	22.67
09AZW	012	2	537	30.41	22.67
	014	2	581	31.49	23.56
	016	2	597	31.31	23.56

Selection procedure (with example)



Condenser capacity ratings are based on the total heat of rejection (THR) of the system. THR is the sum of the net refrigerant effect and the heat of compression added to the refrigerant in the compressor.

The heat of compression varies with the compressor design, so it is best to use the compressor manufacturer's data whenever possible. If the compressor data is not available, the Heat of Rejection tables below may be used to determine the heat of compression.

CAPACITY MULTIPLIERS (HERMETIC COMPRESSORS)

EVAP TEMP (°F)	CONDENSING TEMPERATURE (°F)								
	90	95	100	105	110	115	120	125	130
20	1.26	1.27	1.29	1.31	1.33	1.35	1.37	1.40	1.43
25	1.24	1.25	1.27	1.29	1.31	1.33	1.35	1.37	1.40
30	1.22	1.23	1.25	1.26	1.28	1.30	1.32	1.34	1.37
35	1.20	1.21	1.23	1.25	1.26	1.27	1.29	1.31	1.34
40	1.18	1.19	1.21	1.23	1.24	1.25	1.27	1.29	1.31
45	1.16	1.17	1.19	1.21	1.22	1.23	1.25	1.26	1.28
50	1.14	1.15	1.17	1.19	1.20	1.22	1.23	1.24	1.26

CAPACITY MULTIPLIERS (OPEN COMPRESSORS)

EVAP TEMP (°F)	CONDENSING TEMPERATURE (°F)								
	90	95	100	105	110	115	120	125	130
20	1.17	1.18	1.20	1.22	1.24	1.26	1.28	1.30	1.32
25	1.15	1.17	1.18	1.20	1.22	1.24	1.26	1.28	1.30
30	1.14	1.15	1.17	1.18	1.20	1.22	1.24	1.25	1.27
35	1.13	1.14	1.16	1.17	1.18	1.20	1.21	1.24	1.25
40	1.12	1.14	1.15	1.16	1.17	1.18	1.20	1.21	1.23
45	1.11	1.13	1.14	1.15	1.16	1.17	1.18	1.20	1.21
50	1.09	1.11	1.12	1.13	1.14	1.16	1.17	1.19	1.20

The following formulas may be used to calculate the THR for units outside the range of the tables.

For suction cooled hermetic compressors use:

$$\text{THR} = \text{Compressor Capacity (Btuh)} + (3413 \times \text{kW})$$

For open compressors use:

$$\text{THR} = \text{Compressor Capacity (Btuh)} + (2545 \times \text{brake horsepower})$$

I Determine design conditions.

When selecting a unit find the type of refrigerant, total heat rejection, and saturated discharge temperature (SDT) at the selected load conditions required by the compressor and evaporator.

Given:

Refrigerant R-22
 Entering-Air Temperature 95 F
 Required THR Per Circuit 72,000
 Saturated Discharge Temperature 125 F
 Discharge Line Loss 2° F
 (If Discharge Line Loss is unknown, use 2° F.)

II Select unit based on requirements.

Determine the number of circuits required. Determine if optional subcooling circuit is needed. Determine if a low-sound motor is required.

Given:

Dual Circuits
 With Subcooler
 Standard Motor

III Determine saturated condensing temperature.

$$\begin{aligned} \text{Saturated Condensing Temperature (SCT)} \\ = \text{SCT} - \text{Line Loss} \\ = 125 \text{ F} - 2 \text{ F} = 123 \text{ F} \end{aligned}$$

IV Determine temperature difference (TD).

$$\begin{aligned} \text{TD} = \text{SCT} - \text{Entering-Air Temperature} \\ = 123 \text{ F} - 95 \text{ F} = 28 \text{ F} \end{aligned}$$

V Enter Condenser Ratings table.

Based on temperature difference, refrigerant, subcooler, and dual circuit, select the unit which meets or exceeds the required heat rejection:

5 F subcooling selection, page 18 — By interpolation between 25 F and 30 F the 09AW012 will meet the requirements with 72,000 Btuh THR.

$$\text{Actual TD} = \frac{28 \text{ F} \times 72,000}{72,000} = 27.6 \text{ F}$$

15 F subcooling selection, page 19 — The 09AW012 will not meet the requirements, but by interpolation between 25 F and 30 F the 09AW014 will exceed the requirements with 89,700 Btuh THR.

$$\text{Actual TD} = \frac{28 \text{ F} \times 72,000}{89,700} = 22.5 \text{ F}$$

The 09AW012 meets the required heat rejection at the selected TD with 7 F subcooling. The 09AW014 meets the required heat rejection with 10 F subcooling.

Based on the balance point of heat rejection and capacity with the indoor unit, select the unit which best meets the system needs.

NOTE: Elevation above sea level has an effect on the performance of air cooled condensers. The unit capacities in the tables must be multiplied by the factors in the following table to compensate for various elevations.

ELEVATION (ft)	0	1000	2000	3000	4000	5000	6000	7000
FACTOR	1.0	0.98	0.96	0.93	0.91	0.89	0.87	0.85

Performance data

Condenser ratings



HEAT REJECTION (Tons)* (5 F Subcooling)

UNIT 09AWH, 09AWV	SUB- COOLER	CKTS	TEMPERATURE DIFFERENCE (TD)															
			Refrigerant R-22								Refrigerant R-134a							
			5	10	15	20	25	30	35	40	5	10	15	20	25	30	35	40
001	No	1	3.30	6.70	10.10	13.50	16.80	20.20	23.60	27.00	3.14	6.37	9.60	12.83	15.96	19.19	22.42	25.65
	Yes	1	1.65	3.35	5.05	6.75	8.40	10.10	11.80	13.50	1.57	3.18	4.80	6.41	7.98	9.60	11.21	12.83
002	No	1	5.70	11.40	17.10	22.80	28.60	34.30	40.00	45.70	5.42	10.83	16.25	21.66	27.17	32.59	38.00	43.42
	No	2	2.85	5.70	8.55	11.40	14.30	17.15	20.00	22.85	2.71	5.42	8.12	10.83	13.59	16.29	19.00	21.71
	Yes	1	5.36	10.72	16.07	21.43	26.88	32.24	37.60	42.96	5.09	10.18	15.27	20.36	25.54	30.63	35.72	40.81
	Yes	2	2.68	5.36	8.04	10.72	13.44	16.12	18.80	21.48	2.55	5.09	7.64	10.18	12.77	15.31	17.86	20.41
003	No	1	9.30	18.50	27.70	36.90	46.20	55.40	64.60	73.80	8.84	17.58	26.32	35.06	43.89	52.63	61.37	70.11
	No	2	4.65	9.25	13.85	18.45	23.10	27.70	32.30	36.90	4.42	8.79	13.16	17.53	21.95	26.32	30.69	35.06
	Yes	1	8.74	17.39	26.04	34.69	43.33	52.08	60.72	69.37	8.30	16.52	24.74	32.95	41.26	49.47	57.69	65.90
	Yes	2	4.37	8.70	13.02	17.34	21.71	26.04	30.36	34.69	4.15	8.26	12.37	16.48	20.63	24.74	28.84	32.95
004	No	1	13.10	24.70	36.30	48.30	60.50	72.50	84.50	96.50	12.45	23.47	34.49	45.89	57.48	68.88	80.28	91.68
	No	2	6.55	12.35	18.15	24.15	30.25	36.25	42.25	48.25	6.22	11.73	17.24	22.94	28.74	34.44	40.14	45.84
	Yes	1	12.31	23.22	34.12	45.40	56.87	68.15	79.43	90.71	11.70	22.06	32.42	43.13	54.03	64.74	75.46	86.17
	Yes	2	6.16	11.61	17.06	22.70	28.44	34.08	39.72	45.36	5.85	11.03	16.21	21.57	27.01	32.37	37.73	43.09
006	No	1	18.30	36.80	55.30	73.60	92.10	110.50	128.90	147.30	17.39	34.96	52.54	69.92	87.50	104.98	122.46	139.94
	No	2	9.15	18.40	27.65	36.80	46.05	55.25	64.45	73.65	8.69	17.48	26.27	34.96	43.75	52.49	61.23	69.97
	Yes	1	17.20	34.59	51.98	69.18	86.57	103.87	121.17	138.46	16.34	32.86	49.38	65.72	82.25	98.68	115.11	131.54
	Yes	2	8.60	17.30	25.99	34.59	43.29	51.94	60.58	69.23	8.17	16.43	24.69	32.86	41.12	49.34	57.55	65.77
008	No	1	24.10	48.30	72.50	96.70	120.90	145.00	169.10	193.20	22.90	45.89	68.88	91.87	114.86	137.75	160.65	183.54
	No	2	12.05	24.15	36.25	48.35	60.45	72.50	84.55	96.60	11.45	22.94	34.44	45.93	57.43	68.88	80.32	91.77
	Yes	1	22.65	45.40	68.15	90.90	113.65	136.30	158.95	181.61	21.52	43.13	64.74	86.35	107.96	129.49	151.01	172.53
	Yes	2	11.33	22.70	34.08	45.45	56.82	68.15	79.48	90.80	10.76	21.57	32.37	43.18	53.98	64.74	75.50	86.26
012	No	1	27.70	55.40	83.10	110.80	138.50	166.20	193.90	221.60	26.32	52.63	78.95	105.26	131.58	157.89	184.21	210.52
	No	2	13.85	27.70	41.55	55.40	69.25	83.10	96.95	110.80	13.16	26.32	39.47	52.63	65.79	78.95	92.10	105.26
	Yes	1	26.04	52.08	78.11	104.15	130.19	156.23	182.27	208.30	24.74	49.47	74.21	98.94	123.68	148.42	173.15	197.89
	Yes	2	13.02	26.04	39.06	52.08	65.10	78.11	91.13	104.15	12.37	24.74	37.10	49.47	61.84	74.21	86.58	98.94
014	No	1	36.30	72.50	108.70	144.80	181.00	217.30	253.60	289.90	34.49	68.88	103.27	137.56	171.95	206.44	240.92	275.41
	No	2	18.15	36.25	54.35	72.40	90.50	108.65	126.80	144.95	17.24	34.44	51.63	68.78	85.98	103.22	120.46	137.70
	Yes	1	34.12	68.15	102.18	136.11	170.14	204.26	238.38	272.51	32.42	64.74	97.07	129.31	161.63	194.05	226.46	258.88
	Yes	2	17.06	34.08	51.09	68.06	85.07	102.13	119.19	136.25	16.21	32.37	48.53	64.65	80.82	97.02	113.23	129.44
016	No	1	40.40	80.90	121.40	161.80	202.20	242.70	283.20	323.70	38.38	76.86	115.33	153.71	192.09	230.57	269.04	307.52
	No	2	20.20	40.45	60.70	80.90	101.10	121.35	141.60	161.85	19.19	38.43	57.67	76.86	96.05	115.28	134.52	153.76
	Yes	1	37.98	76.05	114.12	152.09	190.07	228.14	266.21	304.28	36.08	72.24	108.41	144.49	180.56	216.73	252.90	289.06
	Yes	2	18.99	38.02	57.06	76.05	95.03	114.07	133.10	152.14	18.04	36.12	54.21	72.24	90.28	108.37	126.45	144.53
018	No	1	48.40	96.70	145.00	193.40	241.70	290.00	338.30	386.60	45.98	91.87	137.75	183.73	229.62	275.50	321.39	367.27
	No	2	24.20	48.35	72.50	96.70	120.85	145.00	169.15	193.30	22.99	45.93	68.88	91.87	114.81	137.75	160.69	183.64
	Yes	1	45.50	90.90	136.30	181.80	227.20	272.60	318.00	363.40	43.22	86.35	129.49	172.71	215.84	258.97	302.10	345.23
	Yes	2	22.75	45.45	68.15	90.90	113.60	136.30	159.00	181.70	21.61	43.18	64.74	86.35	107.92	129.49	151.05	172.62
020	No	1	53.00	105.90	158.80	211.80	264.70	317.60	370.50	423.40	50.35	100.61	150.86	201.21	251.47	301.72	351.98	402.23
	No	2	26.50	52.95	79.40	105.90	132.35	158.80	185.25	211.70	25.18	50.30	75.43	100.61	125.73	150.86	175.99	201.12
	Yes	1	49.82	99.55	149.27	199.09	248.82	298.54	348.27	398.00	47.33	94.57	141.81	189.14	236.38	283.62	330.86	378.10
	Yes	2	24.91	49.77	74.64	99.55	124.41	149.27	174.14	199.00	23.66	47.28	70.90	94.57	118.19	141.81	165.43	189.05

*Per circuit.



HEAT REJECTION (Tons)* (15 F Subcooling)

UNIT 09AWH, 09AWV	SUB-COOLER	CKTS	TEMPERATURE DIFFERENCE (TD) (F)															
			Refrigerant R-22							Refrigerant R-134a								
			5	10	15	20	25	30	35	40	5	10	15	20	25	30	35	40
001	No	1	N/A	N/A	9.51	12.70	15.81	19.01	22.21	25.41	2.95	5.99	9.03	12.07	15.02	18.06	21.10	24.14
	Yes	1	N/A	N/A	4.75	6.35	7.91	9.51	11.10	12.70	1.48	3.00	4.51	6.03	7.51	9.03	10.55	12.07
002	No	1	N/A	N/A	16.09	21.46	26.92	32.28	37.64	43.01	5.10	10.19	15.29	20.38	25.57	30.67	35.76	40.86
	No	2	N/A	N/A	8.05	10.73	13.46	16.14	18.82	21.50	2.55	5.10	7.64	10.19	12.78	15.33	17.88	20.43
	Yes	1	N/A	N/A	15.13	20.17	25.30	30.34	35.39	40.43	4.79	9.58	14.37	19.16	24.04	28.83	33.62	38.41
	Yes	2	N/A	N/A	7.56	10.08	12.65	15.17	17.69	20.21	2.40	4.79	7.19	9.58	12.02	14.41	16.81	19.20
003	No	1	N/A	N/A	26.07	34.73	43.48	52.14	60.80	69.45	8.31	16.54	24.77	32.99	41.30	49.53	57.76	65.98
	No	2	N/A	N/A	13.03	17.36	21.74	26.07	30.40	34.73	4.16	8.27	12.38	16.50	20.65	24.77	28.88	32.99
	Yes	1	N/A	N/A	24.50	32.64	40.87	49.01	57.15	65.29	7.82	15.55	23.28	31.01	38.83	46.56	54.29	62.02
	Yes	2	N/A	N/A	12.25	16.32	20.44	24.50	28.57	32.64	3.91	7.77	11.64	15.51	19.41	23.28	27.14	31.01
004	No	1	N/A	N/A	34.16	45.46	56.94	68.23	79.52	90.82	11.71	22.08	32.45	43.18	54.09	64.82	75.55	86.28
	No	2	N/A	N/A	17.08	22.73	28.47	34.11	39.76	45.41	5.86	11.04	16.23	21.59	27.04	32.41	37.77	43.14
	Yes	1	N/A	N/A	32.11	42.73	53.52	64.14	74.75	85.37	11.01	20.76	30.51	40.59	50.84	60.93	71.01	81.10
	Yes	2	N/A	N/A	16.06	21.36	26.76	32.07	37.38	42.68	5.50	10.38	15.25	20.30	25.42	30.46	35.51	40.55
006	No	1	N/A	N/A	52.04	69.26	86.68	103.99	121.31	138.62	16.36	32.90	49.44	65.80	82.34	98.79	115.24	131.69
	No	2	N/A	N/A	26.02	34.63	43.34	52.00	60.65	69.31	8.18	16.45	24.72	32.90	41.17	49.40	57.62	65.85
	Yes	1	N/A	N/A	48.92	65.11	81.47	97.75	114.03	130.31	15.38	30.93	46.47	61.85	77.40	92.86	108.33	123.79
	Yes	2	N/A	N/A	24.46	32.55	40.74	48.88	57.01	65.15	7.69	15.46	23.24	30.93	38.70	46.43	54.16	61.90
008	No	1	N/A	N/A	68.23	91.00	113.78	136.46	159.14	181.82	21.55	43.18	64.82	86.45	108.09	129.64	151.18	172.73
	No	2	N/A	N/A	34.11	45.50	56.89	68.23	79.57	90.91	10.77	21.59	32.41	43.23	54.05	64.82	75.59	86.36
	Yes	1	N/A	N/A	64.14	85.54	106.95	128.27	149.59	170.91	20.25	40.59	60.93	81.27	101.60	121.86	142.11	162.37
	Yes	2	N/A	N/A	32.07	42.77	53.48	64.14	74.80	85.46	10.13	20.30	30.46	40.63	50.80	60.93	71.06	81.18
012	No	1	N/A	N/A	78.21	104.27	130.34	156.41	182.48	208.55	24.77	49.53	74.30	99.06	123.83	148.59	173.36	198.12
	No	2	N/A	N/A	39.10	52.14	65.17	78.21	91.24	104.27	12.38	24.77	37.15	49.53	61.91	74.30	86.68	99.06
	Yes	1	N/A	N/A	73.51	98.02	122.52	147.03	171.53	196.03	23.28	46.56	69.84	93.12	116.40	139.67	162.95	186.23
	Yes	2	N/A	N/A	36.76	49.01	61.26	73.51	85.77	98.02	11.64	23.28	34.92	46.56	58.20	69.84	81.48	93.12
014	No	1	N/A	N/A	102.30	136.27	170.34	204.50	238.66	272.82	32.45	64.82	97.18	129.46	161.82	194.28	226.73	259.18
	No	2	N/A	N/A	51.15	68.14	85.17	102.25	119.33	136.41	16.23	32.41	48.59	64.73	80.91	97.14	113.36	129.59
	Yes	1	N/A	N/A	96.16	128.10	160.12	192.23	224.34	256.46	30.51	60.93	91.35	121.69	152.11	182.62	213.13	243.63
	Yes	2	N/A	N/A	48.08	64.05	80.06	96.12	112.17	128.23	15.25	30.46	45.68	60.85	76.06	91.31	106.56	121.82
016	No	1	N/A	N/A	114.25	152.27	190.29	228.40	266.52	304.63	36.12	72.33	108.54	144.66	180.78	216.98	253.19	289.40
	No	2	N/A	N/A	57.12	76.13	95.15	114.20	133.26	152.32	18.06	36.16	54.27	72.33	90.39	108.49	126.60	144.70
	Yes	1	N/A	N/A	107.39	143.13	178.87	214.70	250.53	286.36	33.95	67.99	102.02	135.98	169.93	203.97	238.00	272.04
	Yes	2	N/A	N/A	53.70	71.57	89.44	107.35	125.26	143.18	16.98	33.99	51.01	67.99	84.96	101.98	119.00	136.02
018	No	1	N/A	N/A	136.46	182.01	227.46	272.92	318.37	363.83	43.27	86.45	129.64	172.91	216.09	259.27	302.46	345.64
	No	2	N/A	N/A	68.23	91.00	113.73	136.46	159.19	181.91	21.64	43.23	64.82	86.45	108.05	129.64	151.23	172.82
	Yes	1	N/A	N/A	128.27	171.09	213.82	256.54	299.27	342.00	40.68	81.27	121.86	162.53	203.13	243.72	284.31	324.90
	Yes	2	N/A	N/A	64.14	85.54	106.91	128.27	149.64	171.00	20.34	40.63	60.93	81.27	101.56	121.86	142.15	162.45
020	No	1	N/A	N/A	149.45	199.32	249.11	298.89	348.68	398.46	47.38	94.68	141.97	189.36	236.65	283.95	331.24	378.54
	No	2	N/A	N/A	74.72	99.66	124.55	149.45	174.34	199.23	23.69	47.34	70.99	94.68	118.33	141.97	165.62	189.27
	Yes	1	N/A	N/A	140.48	187.37	234.16	280.96	327.76	374.55	44.54	89.00	133.46	178.00	222.45	266.91	311.37	355.83
	Yes	2	N/A	N/A	70.24	93.68	117.08	140.48	163.88	187.28	22.27	44.50	66.73	89.00	111.23	133.46	155.68	177.91

*Per circuit.

Performance data (cont)

Condenser ratings (cont)



HEAT REJECTION (Tons)* (5 F Subcooling)

UNIT 09AWL, 09AWW	SUB- COOLER	CKTS	TEMPERATURE DIFFERENCE (TD) (F)															
			Refrigerant R-22								Refrigerant R-134a							
			5	10	15	20	25	30	35	40	5	10	15	20	25	30	35	40
001	No	1	3.20	6.40	9.60	12.70	15.90	19.10	22.30	25.50	3.04	6.08	9.12	12.07	15.11	18.15	21.19	24.23
	Yes	1	1.60	3.20	4.80	6.35	7.95	9.55	11.15	12.75	1.52	3.04	4.56	6.03	7.55	9.07	10.59	12.11
002	No	1	5.00	10.00	15.00	20.00	25.00	30.00	35.00	40.00	4.75	9.50	14.25	19.00	23.75	28.50	33.25	38.00
	No	2	2.50	5.00	7.50	10.00	12.50	15.00	17.50	20.00	2.38	4.75	7.13	9.50	11.88	14.25	16.63	19.00
	Yes	1	4.70	9.40	14.10	18.80	23.50	28.20	32.90	37.60	4.47	8.93	13.40	17.86	22.33	26.79	31.26	35.72
	Yes	2	2.35	4.70	7.05	9.40	11.75	14.10	16.45	18.80	2.23	4.47	6.70	8.93	11.16	13.40	15.63	17.86
003	No	1	7.90	15.70	23.50	31.30	39.20	47.00	54.80	62.60	7.51	14.92	22.33	29.74	37.24	44.65	52.06	59.47
	No	2	3.95	7.85	11.75	15.65	19.60	23.50	27.40	31.30	3.75	7.46	11.16	14.87	18.62	22.33	26.03	29.74
	Yes	1	7.43	14.76	22.09	29.42	36.85	44.18	51.51	58.84	7.05	14.02	20.99	27.95	35.01	41.97	48.94	55.90
	Yes	2	3.71	7.38	11.05	14.71	18.42	22.09	25.76	29.42	3.53	7.01	10.49	13.98	17.50	20.99	24.47	27.95
004	No	1	10.10	20.20	30.30	40.30	50.40	60.50	70.60	80.70	9.60	19.19	28.79	38.29	47.88	57.48	67.07	76.67
	No	2	5.05	10.10	15.10	20.15	25.20	30.25	35.30	40.35	4.80	9.60	14.39	19.14	23.94	28.74	33.54	38.33
	Yes	1	9.49	18.99	28.48	37.88	47.38	56.87	66.36	75.86	9.02	18.04	27.06	35.99	45.01	54.03	63.05	72.07
	Yes	2	4.75	9.49	14.24	18.94	23.69	28.44	33.18	37.93	4.51	9.02	13.53	17.99	22.50	27.01	31.52	36.03
006	No	1	15.50	31.20	46.90	62.50	78.10	93.70	109.30	124.90	14.73	29.64	44.56	59.38	74.20	89.02	103.84	118.66
	No	2	7.75	15.60	23.45	31.25	39.05	46.85	54.65	62.45	7.36	14.82	22.28	29.69	37.10	44.51	51.92	59.33
	Yes	1	14.57	29.33	44.09	58.75	73.41	88.08	102.74	117.41	13.84	27.86	41.88	55.81	69.74	83.67	97.60	111.54
	Yes	2	7.29	14.66	22.04	29.38	36.71	44.04	51.37	58.70	6.92	13.93	20.94	27.91	34.87	41.84	48.80	55.77
008	No	1	20.20	40.40	60.60	80.70	100.90	121.10	141.30	161.50	19.19	38.38	57.57	76.67	95.86	115.05	134.24	153.43
	No	2	10.10	20.20	30.30	40.35	50.45	60.55	70.65	80.75	9.60	19.19	28.79	38.33	47.93	57.52	67.12	76.71
	Yes	1	18.99	37.98	56.96	75.86	94.85	113.83	132.82	151.81	18.04	36.08	54.12	72.07	90.10	108.14	126.18	144.22
	Yes	2	9.49	18.99	28.48	37.93	47.42	56.92	66.41	75.91	9.02	18.04	27.06	36.03	45.05	54.07	63.09	72.11
012	No	1	22.10	44.40	66.70	88.90	111.10	133.30	155.50	177.70	21.00	42.18	63.37	84.46	105.55	126.64	147.73	168.82
	No	2	11.05	22.20	33.35	44.45	55.55	66.65	77.75	88.85	10.50	21.09	31.68	42.23	52.77	63.32	73.86	84.41
	Yes	1	20.77	41.74	62.70	83.57	104.43	125.30	146.17	167.04	19.74	39.65	59.56	79.39	99.21	119.04	138.86	158.69
	Yes	2	10.39	20.87	31.35	41.78	52.22	62.65	73.09	83.52	9.87	19.82	29.78	39.69	49.61	59.52	69.43	79.34
014	No	1	31.60	63.30	95.00	126.60	158.30	189.90	221.50	253.10	30.02	60.14	90.25	120.27	150.39	180.41	210.43	240.45
	No	2	15.80	31.65	47.50	63.30	79.15	94.95	110.75	126.55	15.01	30.07	45.13	60.14	75.19	90.20	105.21	120.22
	Yes	1	29.70	59.50	89.30	119.00	148.80	178.51	208.21	237.91	28.22	56.53	84.84	113.05	141.36	169.58	197.80	226.02
	Yes	2	14.85	29.75	44.65	59.50	74.40	89.25	104.11	118.96	14.11	28.26	42.42	56.53	70.68	84.79	98.90	113.01
016	No	1	34.30	68.60	102.90	137.20	171.50	205.80	240.10	274.40	32.59	65.17	97.76	130.34	162.93	195.51	228.10	260.68
	No	2	17.15	34.30	51.45	68.60	85.75	102.90	120.05	137.20	16.29	32.59	48.88	65.17	81.46	97.76	114.05	130.34
	Yes	1	32.24	64.48	96.73	128.97	161.21	193.45	225.69	257.94	30.63	61.26	91.89	122.52	153.15	183.78	214.41	245.04
	Yes	2	16.12	32.24	48.36	64.48	80.61	96.73	112.85	128.97	15.31	30.63	45.94	61.26	76.57	91.89	107.20	122.52
018	No	1	41.10	82.10	123.10	164.10	205.20	246.20	287.20	328.20	39.05	78.00	116.95	155.90	194.94	233.89	272.84	311.79
	No	2	20.55	41.05	61.55	82.05	102.60	123.10	143.60	164.10	19.52	39.00	58.47	77.95	97.47	116.95	136.42	155.90
	Yes	1	38.63	77.17	115.71	154.25	192.89	231.43	269.97	308.51	36.70	73.32	109.93	146.54	183.24	219.86	256.47	293.08
	Yes	2	19.32	38.59	57.86	77.13	96.44	115.71	134.98	154.25	18.35	36.66	54.96	73.27	91.62	109.93	128.23	146.54
020	No	1	44.20	88.40	132.60	176.80	221.00	265.20	309.40	353.60	41.99	83.98	125.97	167.96	209.95	251.94	293.93	335.92
	No	2	22.10	44.20	66.30	88.40	110.50	132.60	154.70	176.80	21.00	41.99	62.99	83.98	104.98	125.97	146.97	167.96
	Yes	1	41.55	83.10	124.64	166.19	207.74	249.29	290.84	332.38	39.47	78.94	118.41	157.88	197.35	236.82	276.29	315.76
	Yes	2	20.77	41.55	62.32	83.10	103.87	124.64	145.42	166.19	19.74	39.47	59.21	78.94	98.68	118.41	138.15	157.88

*Per circuit.



HEAT REJECTION (Tons)* (15 F Subcooling)

UNIT 09AWL, 09AWW	SUB- COOLER	CKTS	TEMPERATURE DIFFERENCE (TD) (F)															
			Refrigerant R-22								refrigerant R-134a							
			5	10	15	20	25	30	35	40	5	10	15	20	25	30	35	40
001	No	1	N/A	N/A	9.03	11.95	14.96	17.98	20.99	24.00	2.86	5.72	8.58	11.35	14.22	17.08	19.94	22.80
	Yes	1	N/A	N/A	4.52	5.98	7.48	8.99	10.49	12.00	1.43	2.86	4.29	5.68	7.11	8.54	9.97	11.40
002	No	1	N/A	N/A	14.12	18.82	23.53	28.23	32.94	37.64	4.47	8.94	13.41	17.88	22.35	26.82	31.29	35.76
	No	2	N/A	N/A	7.06	9.41	11.76	14.12	16.47	18.82	2.24	4.47	6.71	8.94	11.18	13.41	15.65	17.88
	Yes	1	N/A	N/A	13.27	17.69	22.12	26.54	30.96	35.39	4.20	8.40	12.61	16.81	21.01	25.21	29.41	33.62
	Yes	2	N/A	N/A	6.63	8.85	11.06	13.27	15.48	17.69	2.10	4.20	6.30	8.40	10.51	12.61	14.71	16.81
003	No	1	N/A	N/A	22.12	29.46	36.89	44.23	51.57	58.91	7.06	14.04	21.01	27.98	35.05	42.02	48.99	55.97
	No	2	N/A	N/A	11.06	14.73	18.45	22.12	25.79	29.46	3.53	7.02	10.51	13.99	17.52	21.01	24.50	27.98
	Yes	1	N/A	N/A	20.79	27.69	34.68	41.58	48.48	55.38	6.64	13.19	19.75	26.30	32.94	39.50	46.05	52.61
	Yes	2	N/A	N/A	10.39	13.84	17.34	20.79	24.24	27.69	3.32	6.60	9.87	13.15	16.47	19.75	23.03	26.30
004	No	1	N/A	N/A	28.52	37.93	47.43	56.94	66.44	75.95	9.03	18.06	27.09	36.03	45.06	54.09	63.12	72.15
	No	2	N/A	N/A	14.26	18.96	23.72	28.47	33.22	37.97	4.51	9.03	13.54	18.02	22.53	27.04	31.56	36.07
	Yes	1	N/A	N/A	26.80	35.65	44.59	53.52	62.46	71.39	8.49	16.98	25.46	33.87	42.36	50.84	59.33	67.82
	Yes	2	N/A	N/A	13.40	17.83	22.29	26.76	31.23	35.69	4.24	8.49	12.73	16.93	21.18	25.42	29.67	33.91
006	No	1	N/A	N/A	44.14	58.82	73.50	88.18	102.86	117.54	13.86	27.89	41.93	55.88	69.82	83.77	97.72	111.67
	No	2	N/A	N/A	22.07	29.41	36.75	44.09	51.43	58.77	6.93	13.95	20.97	27.94	34.91	41.89	48.86	55.83
	Yes	1	N/A	N/A	41.49	55.29	69.09	82.89	96.69	110.49	13.03	26.22	39.41	52.53	65.64	78.75	91.86	104.97
	Yes	2	N/A	N/A	20.74	27.64	34.54	41.45	48.35	55.25	6.51	13.11	19.71	26.26	32.82	39.37	45.93	52.48
008	No	1	N/A	N/A	57.03	75.95	94.96	113.97	132.98	151.99	18.06	36.12	54.18	72.15	90.21	108.27	126.33	144.39
	No	2	N/A	N/A	28.52	37.97	47.48	56.98	66.49	75.99	9.03	18.06	27.09	36.07	45.10	54.13	63.16	72.19
	Yes	1	N/A	N/A	53.61	71.39	89.26	107.13	125.00	142.87	16.98	33.95	50.93	67.82	84.80	101.77	118.75	135.72
	Yes	2	N/A	N/A	26.80	35.69	44.63	53.56	62.50	71.43	8.49	16.98	25.46	33.91	42.40	50.89	59.37	67.86
012	No	1	N/A	N/A	62.77	83.66	104.56	125.45	146.34	167.23	19.76	39.70	59.63	79.48	99.33	119.18	139.02	158.87
	No	2	N/A	N/A	31.39	41.83	52.28	62.72	73.17	83.62	9.88	19.85	29.82	39.74	49.66	59.59	69.51	79.44
	Yes	1	N/A	N/A	59.01	78.64	98.28	117.92	137.56	157.20	18.57	37.31	56.05	74.71	93.37	112.03	130.68	149.34
	Yes	2	N/A	N/A	29.50	39.32	49.14	58.96	68.78	78.60	9.29	18.66	28.03	37.36	46.68	56.01	65.34	74.67
014	No	1	N/A	N/A	89.40	119.14	148.98	178.71	208.45	238.19	28.25	56.59	84.93	113.19	141.53	169.78	198.03	226.28
	No	2	N/A	N/A	44.70	59.57	74.49	89.36	104.23	119.10	14.13	28.30	42.47	56.59	70.76	84.89	99.02	113.14
	Yes	1	N/A	N/A	84.04	111.99	140.04	167.99	195.95	223.90	26.56	53.20	79.84	106.39	133.04	159.59	186.15	212.71
	Yes	2	N/A	N/A	42.02	56.00	70.02	84.00	97.97	111.95	13.28	26.60	39.92	53.20	66.52	79.80	93.07	106.35
016	No	1	N/A	N/A	96.84	129.12	161.40	193.68	225.96	258.24	30.67	61.33	92.00	122.66	153.33	183.99	214.66	245.33
	No	2	N/A	N/A	48.42	64.56	80.70	96.84	112.98	129.12	15.33	30.67	46.00	61.33	76.66	92.00	107.33	122.66
	Yes	1	N/A	N/A	91.03	121.37	151.71	182.06	212.40	242.74	28.83	57.65	86.48	115.30	144.13	172.95	201.78	230.61
	Yes	2	N/A	N/A	45.51	60.69	75.86	91.03	106.20	121.37	14.41	28.83	43.24	57.65	72.06	86.48	100.89	115.30
018	No	1	N/A	N/A	115.85	154.43	193.11	231.70	270.28	308.87	36.75	73.40	110.06	146.71	183.46	220.11	256.77	293.43
	No	2	N/A	N/A	57.92	77.22	96.56	115.85	135.14	154.43	18.37	36.70	55.03	73.36	91.73	110.06	128.38	146.71
	Yes	1	N/A	N/A	108.90	145.17	181.53	217.80	254.07	290.34	34.54	69.00	103.45	137.91	172.45	206.91	241.36	275.82
	Yes	2	N/A	N/A	54.45	72.58	90.76	108.90	127.03	145.17	17.27	34.50	51.73	68.96	86.23	103.45	120.68	137.91
020	No	1	N/A	N/A	124.79	166.39	207.98	249.58	291.18	332.77	39.52	79.03	118.55	158.07	197.58	237.10	276.62	316.13
	No	2	N/A	N/A	62.39	83.19	103.99	124.79	145.59	166.39	19.76	39.52	59.28	79.03	98.79	118.55	138.31	158.07
	Yes	1	N/A	N/A	117.30	156.40	195.50	234.60	273.71	312.81	37.15	74.29	111.44	148.58	185.73	222.87	260.02	297.17
	Yes	2	N/A	N/A	58.65	78.20	97.75	117.30	136.85	156.40	18.57	37.15	55.72	74.29	92.86	111.44	130.01	148.58

*Per circuit.

Performance data (cont)

Condenser ratings (cont)



HEAT REJECTION (Tons)* (5 F Subcooling)

UNIT 09AZH, 09AZV	SUB- COOLER	CKTS	TEMPERATURE DIFFERENCE (TD) (F)															
			Refrigerant R-22								Refrigerant R-134a							
			5	10	15	20	25	30	35	40	5	10	15	20	25	30	35	40
006	Yes	1	13.68	25.79	37.90	50.43	63.17	75.70	88.23	100.76	12.99	24.50	36.01	47.91	60.01	71.92	83.8	95.72
008	Yes	1	22.23	44.54	66.86	89.18	111.50	133.73	155.95	178.18	21.11	42.32	63.52	84.72	105.93	127.04	127.04	169.27
012	Yes	2	27.70	55.40	83.10	61.03	152.60	166.20	179.80	193.40	26.32	52.63	78.95	57.98	144.97	157.89	170.81	183.73
014	Yes	2	36.78	73.66	110.53	147.32	184.10	220.97	257.85	294.72	34.94	69.98	105.01	139.95	174.90	209.93	244.96	279.99
016	Yes	2	42.64	85.38	128.12	170.76	213.40	256.14	298.69	341.63	40.51	81.11	121.72	162.22	202.73	243.34	283.94	324.55

HEAT REJECTION (Tons)* (15 F Subcooling)

UNIT 09AZH, 09AZV	SUB- COOLER	CKTS	TEMPERATURE DIFFERENCE (TD) (F)															
			Refrigerant R-22								Refrigerant R-134a							
			5	10	15	20	25	30	35	40	5	10	15	20	25	30	35	40
006	Yes	1	N/A	N/A	35.67	47.46	59.45	71.24	146.77	94.82	12.23	23.06	33.89	45.09	56.48	67.68	78.88	90.08
008	Yes	1	N/A	N/A	62.92	83.93	104.93	125.85	169.21	167.68	19.87	39.82	59.78	79.73	99.69	119.56	139.4	159.30
012	Yes	2	N/A	N/A	78.21	57.43	143.61	156.41	169.21	182.01	24.77	49.53	74.30	54.56	136.43	148.59	160.75	172.91
014	Yes	2	N/A	N/A	104.02	138.64	173.26	207.96	242.66	277.36	32.89	65.85	98.82	131.71	164.59	197.56	230.53	263.50
016	Yes	2	N/A	N/A	120.58	160.70	200.83	241.06	281.28	321.51	38.12	76.33	114.55	152.67	190.79	229.00	267.22	305.43

HEAT REJECTION (Tons)* (5 F Subcooling)

UNIT 09AWL, 09AWW	SUB- COOLER	CKTS	TEMPERATURE DIFFERENCE (TD) (F)															
			Refrigerant R-22								Refrigerant R-134a							
			5	10	15	20	25	30	35	40	5	10	15	20	25	30	35	40
006	Yes	1	12.67	25.51	38.34	51.09	63.85	76.60	89.35	102.11	12.04	24.23	36.42	48.54	60.65	72.77	84.89	97.00
008	Yes	1	18.68	37.36	56.05	74.64	93.32	112.00	130.68	149.36	17.75	35.50	53.24	70.90	88.65	106.40	124.15	141.90
012	Yes	2	30.04	60.08	90.12	120.16	150.20	180.24	210.28	240.32	28.54	57.08	85.61	114.15	142.69	171.23	199.77	228.30
014	Yes	2	36.49	72.90	109.30	145.71	182.20	218.60	255.01	291.41	34.67	69.25	103.84	138.42	173.09	207.67	242.26	276.84
016	Yes	2	42.32	84.64	126.96	169.28	211.60	253.92	296.24	338.56	40.20	80.41	120.61	160.82	201.02	241.22	281.43	321.63

HEAT REJECTION (Tons)* (15 F Subcooling)

UNIT 09AWL, 09AWW	SUB- COOLER	CKTS	TEMPERATURE DIFFERENCE (TD) (F)															
			Refrigerant R-22								Refrigerant R-134a							
			5	10	15	20	25	30	35	40	5	10	15	20	25	30	35	40
006	Yes	1	N/A	N/A	36.08	48.08	60.09	72.09	84.09	96.09	11.33	22.80	34.28	45.68	57.08	68.48	79.89	91.29
008	Yes	1	N/A	N/A	52.75	70.24	87.82	105.40	122.98	140.57	16.70	33.41	50.11	66.73	83.43	100.13	116.84	133.54
012	Yes	2	N/A	N/A	84.81	113.08	141.35	169.62	197.89	226.17	26.86	53.71	80.57	107.43	134.29	161.14	188.00	214.86
014	Yes	2	N/A	N/A	102.86	137.12	171.47	205.73	239.99	274.25	32.63	65.17	97.72	130.27	162.89	195.44	227.99	260.54
016	Yes	2	N/A	N/A	119.48	159.31	199.14	238.96	278.79	318.62	37.84	75.67	113.51	151.34	189.18	227.02	264.85	302.69

*Per circuit.

Typical wiring schematic



09AW014-020

SINGLE PHASE POWER SCHEMATIC

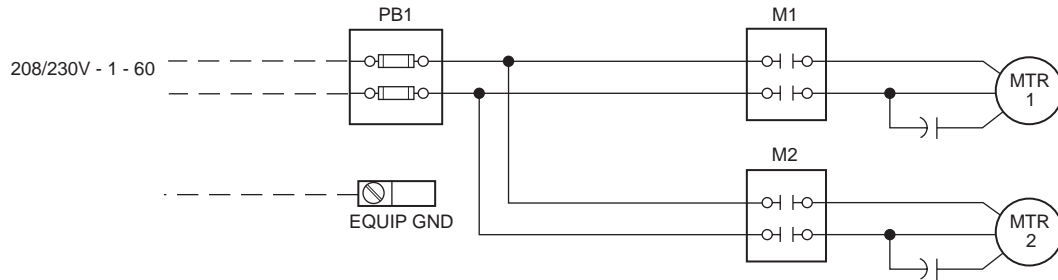

CONTROL SCHEMATIC

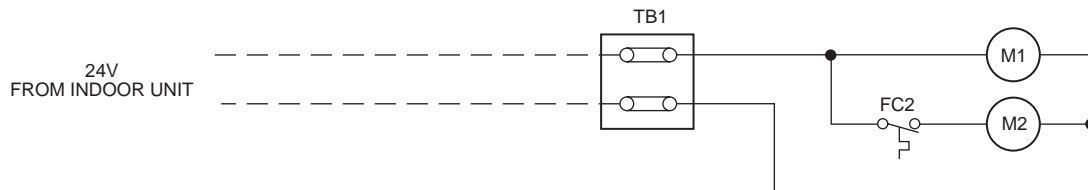

THREE PHASE POWER SCHEMATIC

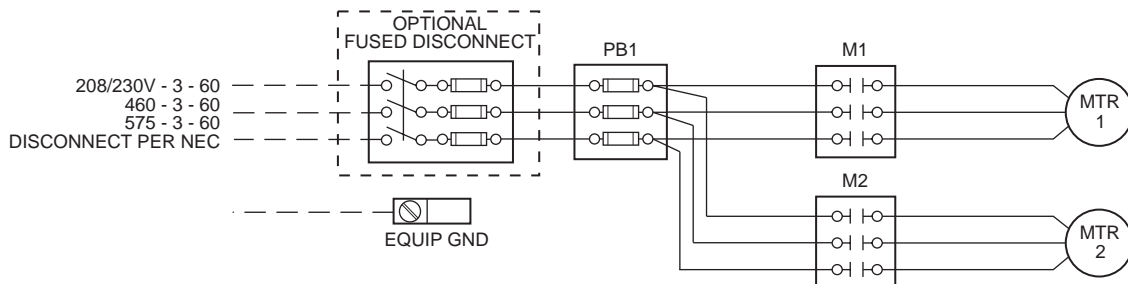

CONTROL SCHEMATIC

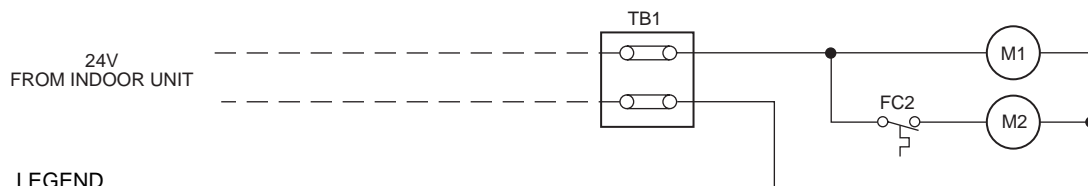

LEGEND

EQUIP	— Equipment
FB1	— Fuse Block
FC2	— Fan Cycling Control
GND	— Ground
M1, M2	— Fan Motor Contactor
MTR1, MTR2	— Fan Motor
NEC	— National Electrical Code
PB1	— Power Terminal Block
TB1	— Control Terminal Block

NOTES:

1. Motor 1 is located on header end of the unit.
2. Field control connections are made to terminal block TB1. Contactor (when supplied) holding voltage is 24 volts.
3. See unit wiring book for wiring with factory-installed head pressure control.

CONDENSER WITH SINGLE COMPRESSOR

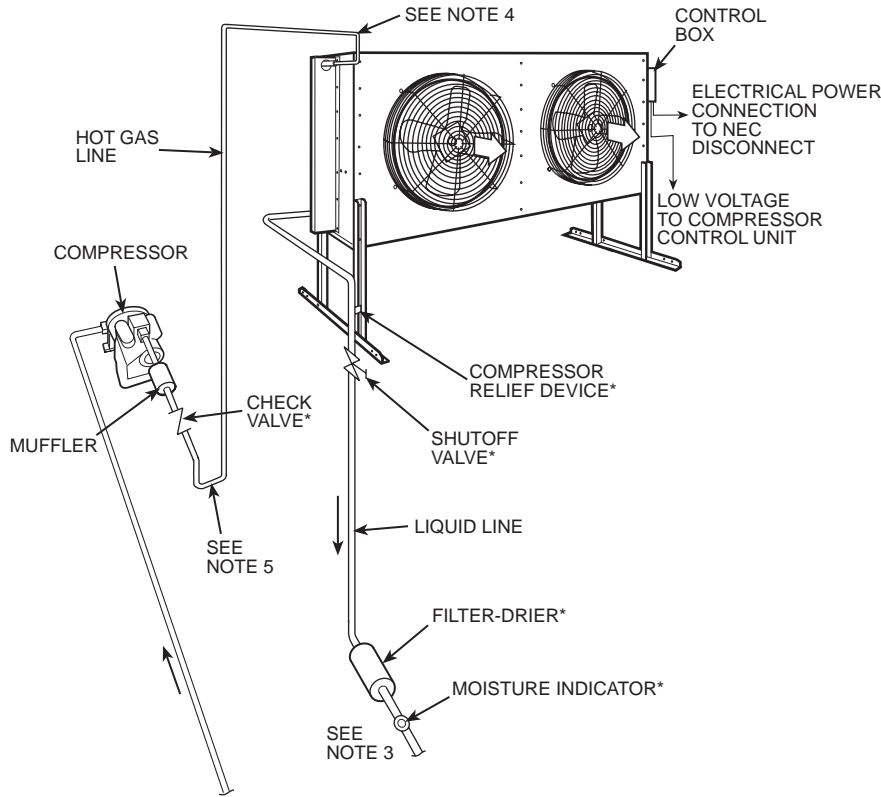

*Field supplied.

NOTES:

1. Wiring and piping shown are general points of connection guides only and are not intended for or to include all details for a specific installation.
2. All wiring must comply with applicable local and national codes.
3. All piping must follow standard piping techniques. Refer to Carrier System Design Manual, part 3, or the Carrier E20-II® Software Refrigerant Piping program, for proper piping sizes and design.
4. Hot gas lines should rise above refrigerant level in condenser circuit.
5. Trap should be installed on hot gas lines to prevent condenser oil and refrigerant vapor migration from accumulating on compressor heads during off cycle.
6. For piping lengths greater than 50 ft (15.2 m), provide support to liquid and gas lines near the connections to the coil.
7. Pitch all horizontal lines downward in the direction of refrigerant flow.
8. For pressure relief requirements, see latest revision of ASHRAE (American Society of Heating, Refrigeration, and Air Conditioning Engineers) Standard 15, Safety Code for Mechanical Refrigeration.

CONDENSER WITH DUAL SPLIT SYSTEM

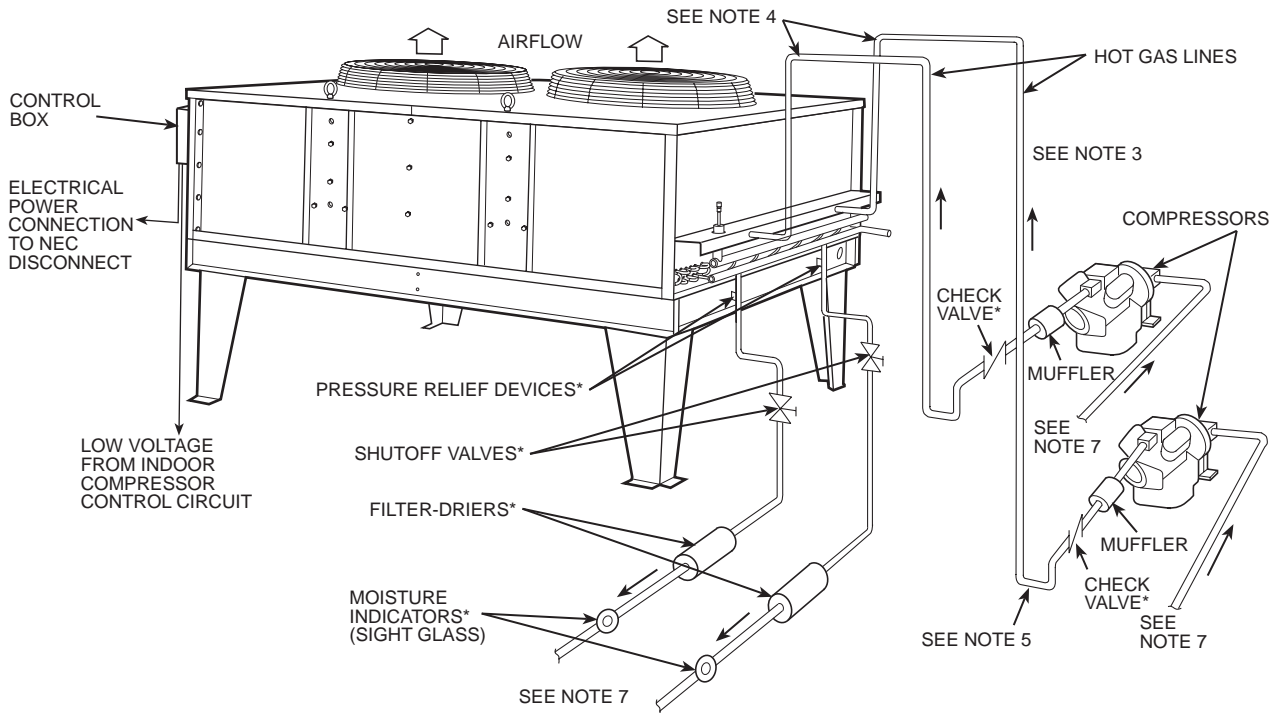

Electrical data



UNIT 09AWH, 09AWV	V-PH-Hz	VOLTAGE RANGE		CONDENSER FAN			POWER SUPPLY*	
		Min	Max	†	Hp/Fan	FLA	MCA	MOCP
001, 002, 003, 004	208/230-1-60	187	253	1	½	2.5	15	15
	208/230-3-60	187	253	1	½	2.0	15	15
	460-3-60	414	506	1	½	1.0	15	15
	575-1-60	518	632	1	½	1.0	15	15
006, 008, 012	208/230-1-60	187	253	2	½	2.5	15	15
	208/230-3-60	187	253	2	½	2.0	15	15
	460-3-60	414	506	2	½	1.0	15	15
	575-1-60	518	632	2	½	1.0	15	15
014, 016, 018, 020	208/230-1-60	187	253	2	1	4.4	15	15
	208/230-3-60	187	253	2	1	4.0	15	15
	460-3-60	414	506	2	1	2.0	15	15
	575-3-60	518	632	2	1	1.7	15	15

UNIT 09AZH, 09AZV	V-PH-Hz	VOLTAGE RANGE		CONDENSER FAN			POWER SUPPLY*	
		Min	Max	†	Hp/Fan	FLA	MCA	MOCP
006	208/230-1-60	187	253	1	½	2.5	15	15
	208/230-3-60	187	253	1	½	2.0	15	15
	460-3-60	414	506	1	½	1.0	15	15
	575-1-60	518	632	1	½	1.0	15	15
008	208/230-1-60	187	243	2	½	2.5	15	15
	208/230-3-60	187	253	2	½	2.0	15	15
	460-3-60	414	506	2	½	1.0	15	15
	575-1-60	518	632	2	½	1.0	15	15
012, 014, 016	208/230-1-60	187	253	2	1	4.4	15	15
	208/230-3-60	187	253	2	1	4.0	15	15
	460-3-60	414	506	2	1	2.0	15	15
	575-3-60	518	632	2	1	1.7	15	15

UNIT 09AWL, 09AWW	V-PH-Hz	VOLTAGE RANGE		CONDENSER FAN			POWER SUPPLY*	
		Min	Max	†	Hp/Fan	FLA	MCA	MOCP
001, 002, 003, 004	208/230-1-60	187	253	1	¼	1.4	15	15
	208/230-3-60	187	253	1	¼	1.4	15	15
	460-3-60	414	506	1	¼	0.65	15	15
006, 008, 012	208/230-1-60	187	243	2	¼	1.4	15	15
	208/230-3-60	187	253	2	¼	1.4	15	15
	460-3-60	414	506	2	¼	0.65	15	15
014, 016, 018, 020	208/230-1-60	187	253	2	½	2.7	15	15
	208/230-3-60	187	253	2	½	2.2	15	15
	460-3-60	414	506	2	½	1.1	15	15

UNIT 09AWL, 09AWW	V-PH-Hz	VOLTAGE RANGE		CONDENSER FAN			POWER SUPPLY*	
		Min	Max	†	Hp/Fan	FLA	MCA	MOCP
006, 008	208/230-1-60	187	253	2	¼	1.4	15	15
	208/230-3-60	187	253	2	¼	1.4	15	15
	460-3-60	414	506	2	¼	0.65	15	15
012, 014, 016	208/230-1-60	187	253	2	½	2.7	15	15
	208/230-3-60	187	253	2	½	2.2	15	15
	460-3-60	414	506	2	½	1.1	15	15

LEGEND

- FLA — Full Load Amps
- MCA — Minimum Circuit Amps
- MOCP — Maximum Overcurrent Protective Device (see Note 1)
- NEC — National Electrical Code

*Min Ckt Amps and MOCP Amps values per NEC rounded to full wire size (see Note 1).

†Fan quantity.

NOTES:

1. In compliance with NEC requirements for multimotor and combination load equipment (NEC Articles 430 and 440), the overcurrent protective device for the unit shall be either circuit breaker (where available) or fuse. Canadian units may be fuse or circuit breaker.
2. Wire sizing amps (MCA) are a sum of 125% of the condenser-fan motor FLA.
3. Motors are protected against primary single phasing condition.
4. Three-phase voltage imbalance must not exceed 2%.
5. 575-v units not available with low sound motors.

Operating sequence

The 09AW,AZ condensing unit may be used with different types of compressor and evaporator combinations. The sequence of operation is dependent on the compressor and specific indoor unit.

General application — Whenever there is a call for cooling the condenser fan starts with the compressor and runs as long as there is a call for cooling. On 2 circuit units both fans are activated on the call for first stage and run with the lead compressor.

Application with 50BZ units — The following control sequence is for the 09AW and 09AZ when matched with the 50BZ unit.

Cooling — On a call for cooling, the thermostat closes and energizes terminals Y1 and T1 on the 50BZ unit low voltage terminal strip. The fan-motor contactor (M) is energized with 24 v through terminals T1 and C. The fan(s) will continue to run until the thermostat is satisfied. At that time, the thermostat will open T1, and the fan will stop immediately.

If the condenser-fan motor overheats due to motor overload or lack of cooling air, the internal fan protector will open the circuit internally in the motor, and the fan will stop. If a safety control in the 50BZ unit opens, the 09AW or 09AZ condenser fan will not be affected, and the fan will continue to run as long as the thermostat is closed.

Factory-installed optional controls

Fan cycling head pressure control — This option allows operations to 30 F (depending on load) by stopping the second condenser fan at outdoor temperatures below 60 F. It is recommended that the second fan on all 2 condenser-fan units be equipped with this option to better match load to condenser capacity.

NOTE: This option will be installed on all 2 condenser-fan units with speed control.

Speed head pressure control (low ambient kit) — This option contains a fan speed-control device activated by a pressure sensor. With the speed control, the condenser-fan motor speed is controlled in response to the saturated condensing pressure. This factory-installed option maintains the condensing temperature at $100 \pm 10^\circ \text{ F}$ ($38 \pm 6^\circ \text{ C}$) for outdoor temperatures down to -20 F (-29 C).

The speed control consists of a solid-state circuit on a printed circuit board, sensor, transformer, and single phase compatible condenser-fan motor.

NOTE: The fan cycling head pressure control is included on all 2 condenser-fan units with speed control.

Field-installed controls

Defrost thermostat (50BB-900---001) — The defrost thermostat is installed on the evaporator coil and is recommended for use with the winter start control. The thermostat will open the control switch if frost begins to form on the evaporator coil. The compressor will stop but the 09AW or 09AZ unit will continue to run.

Solenoid valve — A field-supplied solenoid valve (located at indoor unit) wired in parallel with the compressor contactor coil will shut off the liquid line to prevent refrigerant migration back to the compressor during the off cycle. This valve is recommended for installations where piping length is over 75 ft (22.9m). If 2 liquid line solenoid valves are used (units over $7\frac{1}{2}$ tons), check available transformer volt-ampere capability.

Winter start (38AE-900---021) — When used in conjunction with the speed control option, the winter start control will bypass the low pressure switch for 3 minutes on compressor start-up to allow system pressures to stabilize.

NOTE: If units matched with 09AW or 09AZ condenser units are equipped with a 27 psig low-pressure switch (i.e., 50BZ), the 3-minute low-pressure switch bypass is recommended for operation below 50 F.

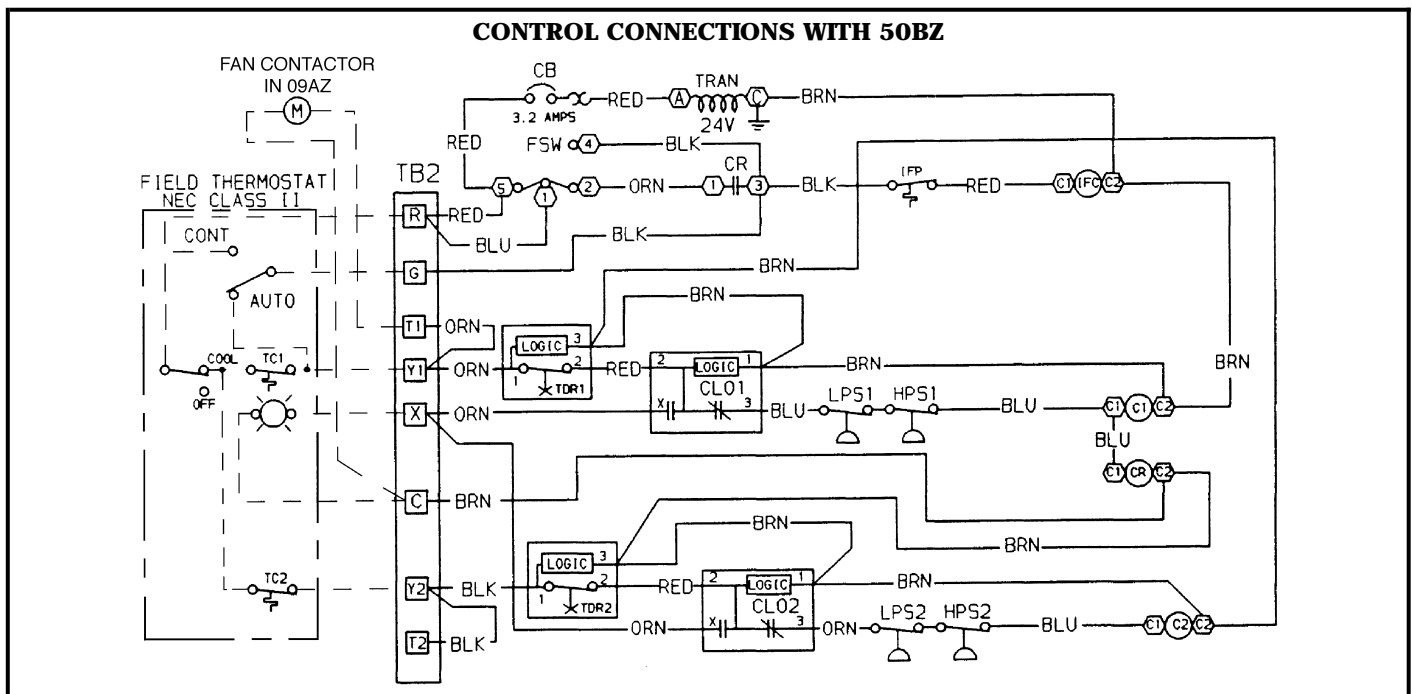

Location

For best results unit must be properly located and installed in an area having adequate airflow. Locate condenser where an adequate supply of outdoor air is available. Do not locate where the possibility of air recirculation exists, such as under a roof overhang. Locate condenser in an area free from airborne dirt or other foreign material which could clog condenser coils. Recirculation of condenser air will result in increased head pressure which may cause units to trip on high pressure.

If roof installation is required, make certain that roof structure can support the condenser weight.

The 09AW and 09AZ units are designed for outdoor applications. If the unit is mounted indoors, provisions must be made to ensure that discharge air is not recirculated into the unit.

Horizontal units 09AWH,AWL,AZH,AZL should be installed with coil side facing the prevailing winds. If strong variable winds are common, it is recommended that a field fabricated wind deflector be used on the discharge side of the unit. Maintain at least 24 inches between the face of the coil and any obstruction such as another unit or a wall. If the unit discharges toward a wall, space the unit at least 60 inches from the wall. If several units are installed in the same area, make sure that discharge air from one unit does not become intake air for another.

Unit mounting

Vertical units 09AWV,AWW,AZV,AZW and smaller horizontal units, when installed as vertical discharge units, should be located no closer than the width of the unit to an obstruction, such as a wall or another unit. Keep the area around each unit clear to avoid restricting the airflow to the unit. There should be 4 ft (1.22 m) for service and for unrestricted airflow on all sides of unit and a minimum 8 ft (2.44 m) clear air space above units. For multiple units, allow width of unit separation between units for airflow and service.

Models 09AW001-012, 09AZ006, and 09AZ008 can be assembled for either horizontal or vertical airflow. The mounting stand is shipped unassembled with each unit. It is a simple procedure to assemble the stand to the unit for either vertical or horizontal airflow.

Vertical airflow units 09AWV,AWW014-020 and 09AZV,AZW012-016 are shipped with the legs installed and with the unit in its normal operating position. No assembly is required. Horizontal models 09AWH,AWL014-020 and 09AZH,AZL012-016 must have the legs field installed. Legs are shipped with the unit.

Make sure units are installed level to ensure proper drainage of liquid refrigerant and oil. When units are installed on a roof, they must be mounted on support beams that span load walls. Ground mounted units should be installed on concrete pads of sufficient size to prevent grass and brush from blocking the unit inlet. When unit is in proper location, use mounting holes in legs for securing unit to supporting structure.

Unit isolation

Fasteners for mounting unit must be field supplied. If unit is to be mounted on vibration isolators, use mounting holes in

bottom of support legs as support points and locate isolators at those points. If vibration isolation is desired, rubber-in-shear pads are recommended under the four corners of the unit. Spring isolation is not recommended for floor-mounted units, but may be used for suspended units.

Ductwork for condenser air

Condenser supply and discharge must have adequate airflow. If the unit is ducted, the duct must not add more than 0.1 in. wg to the static pressure imposed on the fans. An 0.1 in. wg added static will decrease total heat rejection capability by approximately 3.2%.

Liquid lift and subcooling circuit

Amount of liquid lift available before refrigerant flashing occurs depends on amount of liquid subcooling in the system. All 9AW,AZ condensers have positive subcooling when applied with charge for 15 F subcooling and subcooling circuit. With subcooling, it is possible to overcome an appreciable pressure drop and/or static head pressure due to elevation of the liquid metering device above the condenser when condenser is below evaporator coil. However, subcooling will decrease the total heat rejection capability of the condenser. Subcooling results when a portion of the condenser tubes fill with liquid refrigerant, decreasing the condensing area.

The subcooling circuit option decreases condenser area (capacity) available for gas to liquid condensing by using some tubes as a fast pass to ensure positive subcooling. The condensing circuits are combined and feed through the subcooling circuit to flood with liquid refrigerant and drop the temperature below the saturated condensing temperature. Subcooling requirements and the need for the optional subcooling circuit depends on the system design.

When 09AW,AZ condensers are applied with 5 F subcooling, they may not provide positive subcooling. If subcooling is required, it must be obtained by external means such as a liquid suction interchanger or the subcooling circuiting option available on all units. It is recommended that the evaporator be either at the same level as the condenser or lower than the condenser when 5 F subcooling is used.

Refrigerant line sizing

Sizing depends on length of lines between various sections of the refrigerant system. Consider the amount of liquid lift and drop in the system as well as proper compressor oil return. Consult Carrier System Design Manual, part 3, for proper piping sizes and design.

Use the following guideline for refrigerant piping:

Discharge lines

- Base line size on a 2° F change in saturated condensing temperature.
- Lines must be sized and routed so that oil is carried through the system. When the condenser is located at a higher level than the compressor, take special precautions that oil will return at reduced capacity. A double hot gas riser may be required with high lift and a large degree of unloading. Be sure to trap the connections between both risers.

NOTE: Double hot gas riser shown on next page.

Protect the compressor from liquid refrigerant or oil draining back during compressor off cycles. The highest point in the discharge line should be above highest point in the condenser coil. A purge valve should be applied at this point. The hot gas line should loop to the floor if the condenser is located above the compressor, especially if the hot gas riser is long. If the condenser is located where the entering-air temperature could be higher than the entering-air temperature at the compressor location, a check valve should be installed in the hot gas line.

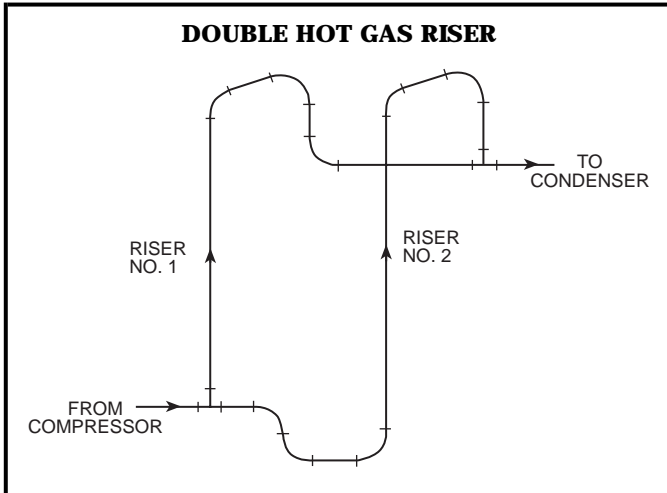

Liquid lines

- Liquid lines can generally be sized for a 1 to 2° F change in saturation temperature.
- Liquid lines should be as small as possible to minimize system change.
- Piping should be routed to avoid excessive strain on system components or the piping itself. Discharge lines must be supported with rigid pipe supports to prevent transmission of vibration and movement of the line. The discharge line should be well supported near the condenser hot gas connection. Use offsets in interconnecting lines between 2 condensers and provide isolation where pipes pass through building walls or floors.

NOTE: A receiver, if used in the system, should be located below the condenser, and the condenser to receiver liquid line must be sized to allow free drainage. This line should be sized so the velocity does not exceed 100 fpm. Generous sizing of this liquid (condensate) line is especially important if the receiver is exposed at any time to a warmer entering-air temperature than the condenser. It must be large enough for the liquid to flow to the receiver and, at the same

time, allow flow of refrigerant vapor in the positive direction back to the condenser. The receiver will become vapor locked under these conditions if re-evaporated gas is not allowed to flow back to the condenser for re-condensation. Liquid lines should be free of any traps or loops.

Condenser head pressure control

Efficient operation of evaporator thermostatic expansion valve requires a 90 F minimum saturated condensing temperature when compressors are not operating at 100% capacity, 80 F for 75% capacity, and 70 F for 50 and 25% capacity.

A drop in the entering-air temperature results in a lower saturated condensing temperature. When outdoor-air temperature drops below the minimum temperature listed in the Minimum Outdoor-Air Operating Temperature table below, head pressure control is required.

On 2 condenser-fan units, fan cycling control can be applied to one fan to achieve head pressure control. When fan cycling alone will not achieve the required minimum motor speed control is required. When motor speed control is used on 2-fan units, it is always applied with fan cycling control on the other motor.

NOTE: Minimum Outdoor-Air Operating Temperature table shows the minimum temperature with fan cycling control and head pressure control.

Units are not qualified for use with Motormaster® speed control, but use a similar device. When outdoor temperatures are low enough to cause low condensing pressures, the head pressure control modulates the motor speed of one condenser fan from full to minimum rpm to maintain a constant saturated condensing temperature for full year-round head pressure control. The control works only with single phase motors, so on 3-phase units the motor is changed to a single-phase motor. When units have a low-pressure switch, the use of the winterstart kit (38AE-900---021) is recommended. The winterstart kit bypasses the low-pressure switch on start-up. The use of the defrost thermostat kit (50BB-900---001) also is recommended to sense frost on the evaporator coil if suction temperature drops too low.

Process applications

Process applications are defined as heat rejection loads which are not related to or significantly affected by outdoor conditions. Process applications tend to have constant heat rejection requirements throughout the year. Consequently, these applications may require switching the set point of the fan cycling control. Consult application engineering for assistance in designing and selecting process systems.



MINIMUM OUTDOOR-AIR OPERATING TEMPERATURE

FAN	HEAD PRESSURE CONTROL	REFRIGERANT TEMPERATURE DIFFERENCE	COMPRESSOR CAPACITY (%)			
			100	75	50	25
			Minimum Outdoor Air Temperatures (F)			
1	None	30	60	57	55	62
		25	65	61	57	64
		20	70	65	60	65
	Head Pressure Control	30	-20	-20	-20	-20
		25				
		20				
2	None	30	60	57	55	62
		25	65	61	57	64
		20	70	65	60	65
	Fan Cycle Switch	30	33	38	42	56
		25	43	45	47	58
		20	52	52	51	61
	Head Pressure Control	30	-20	-20	-20	-20
		25				
		20				

SOUND POWER LEVELS -dB (10 [-12] Watts)

UNIT 09AW (H,V)	OUTDOOR FAN						
	125	250	500	1000	2000	4000	8000
001	78	72	64	64	61	58	55
002	78	72	64	64	61	58	55
003	78	72	64	64	61	58	55
004	78	72	64	64	61	58	55
006	78	72	64	64	61	58	55
008	78	72	64	64	61	58	55
012	78	72	64	64	61	58	55
014	81	75	67	67	64	61	58
016	81	75	67	67	64	61	58
018	81	75	67	67	64	61	58
020	81	75	67	67	64	61	58
(L,W)							
001	70	67	59	59	55	54	52
002	70	67	59	59	55	54	52
003	70	67	59	59	55	54	52
004	70	67	59	59	55	54	52
006	70	67	59	59	55	54	52
008	70	67	59	59	55	54	52
012	70	67	59	59	55	54	52
014	73	70	62	62	58	57	55
016	73	70	62	62	58	57	55
018	73	70	62	62	58	57	55
020	73	70	62	62	58	57	55
09AZ (H,V)							
006	78	72	64	64	61	58	55
008	78	72	64	64	61	58	55
012	81	75	67	67	64	61	58
014	81	75	67	67	64	61	58
016	81	75	67	67	64	61	58
(L,W)							
006	70	67	59	59	55	54	52
008	70	67	59	59	55	54	52
012	73	70	62	62	58	57	55
014	73	70	62	62	58	57	55
016	73	70	62	62	58	57	55

Air-Cooled Condensers

HVAC Guide Specifications

Size Range: **1 to 20 Tons**

Carrier Model Number: **09AW**

Part 1 — General

1.01 SYSTEM DESCRIPTION

Outdoor mounted, packaged air-cooled remote condenser. Unit shall discharge condenser air vertically or horizontally as shown on contract drawings.

1.02 QUALITY ASSURANCE

- A. Units shall be rated using refrigerant R-22 or R-134a. Ratings shall be listed at 5 F subcooling and 15 F subcooling refrigerant charge and in accordance with ARI Standard 460.
- B. Unit shall be designed to conform to the latest ANSI/ASHRAE 15 revision safety code, and UL Standard 1995, and shall be UL listed under both American and Canadian Standards.
- C. Coils shall be leak tested at 400 psig and unit operation shall be tested at the factory.

1.03 DELIVERY, STORAGE AND HANDLING

Units shall be stored and handled according to manufacturer's recommendations.

Part 2 — Products

2.01 EQUIPMENT

A. General:

Outdoor mounted, packaged, air-cooled remote condenser. Factory-assembled unit shall consist of condenser coil, fan(s) and motor(s), mounting legs, factory wiring, piping and controls, and a charge of dry nitrogen.

B. Unit Cabinet:

- 1. Cabinet shall be constructed of minimum 18 gage corrosion resistant zinc coated galvanized steel and are capable of withstanding Federal test Method Standard No. 141 (Method 6061) 500-hour salt spray test. Optional heavy gage embossed aluminum shall be available.
- 2. Two-fan units shall be divided by full-width baffles to separate individual fan sections, prevent air bypass, and provide additional casing rigidity.
- 3. Units 12 ton and larger shall be furnished with lifting eyes to aid in rigging.
- 4. Panels for servicing shall be easily removable using a single wrench size.
- 5. Unit sizes 1 ton to 10 ton shall have minimum 12 gage galvanized steel mounting legs 15 in. high and mounting rails. Legs shall be shipped with the unit for field assembly. Headers shall be arranged for horizontal or vertical airflow.
- 6. Unit sizes 12 ton to 20 ton shall have minimum 10 gage galvanized steel legs 18 in. high and 12 gage base rail.
- 7. Unit sizes 12 to 20 ton shall be factory arranged for vertical or horizontal airflow as required. Headers shall have proper arrangement and

connection locations for correct refrigerant and oil return for the required airflow.

C. Fans:

Fans shall be propeller type, direct driven by weatherproof motors, and dynamically balanced. Discharge side shall be protected by corrosion-resistant fan guards constructed of vinyl coated close-mesh steel wire. Fans shall have dual square head set screws spaced 90 degrees apart that seat onto one flat and one keyway on the motor shaft.

D. Coils:

Coils shall use copper tubes, aluminum fin (or optional copper tube with copper fin, or be coated with polyester or phenolic fin treatment as required) and galvanized steel tube sheets. Fins shall be bonded to tubes by mechanical expansion. Hot gas and liquid connections shall be made from the same end. Coil circuiting shall be single (100% capacity) or dual (50/50% capacity) circuit with or without a final pass subcooling circuit as required by the application. Fins shall not exceed 14 fins per inch.

E. Motors:

Motors shall be weatherproof and inherently protected to operate at the specified electrical characteristics. Motor shall have permanently lubricated ball bearings. When required by environmental conditions, optional TEAO (Totally Enclosed, Air Over) motors shall be used. Motors shall be factory wired to weatherproof NEMA 3R control box on opposite header end of unit. Fan motors shall be a rigid base type mounted to 12 gage galvanized steel rails. When required by specification low-sound motors shall be provided.

F. Operating Characteristics:

Unit shall be capable of rejecting the required heat at the required cfm and be capable of operating at moderate entering-air temperatures as standard and at reduced entering-air temperatures with optional fan cycling or fan motor speed control.

G. Electrical Characteristics:

All electrical power wiring shall enter the unit cabinet at a single location. Control circuit is 24 v and control wiring shall enter the unit control box at one connection only.

H. Special Features:

Units shall be furnished with optional factory mounted or field-installed special features (as required by application).

- 1. Embossed Aluminum cabinet shall be provided for enhanced appearance and corrosion protection.
- 2. Extended 30-in. mounting legs for unit sizes 12 ton and larger.
- 3. Low sound condenser-fan motors shall be furnished for lower condenser-fan sound applications.
- 4. Fan contactor shall be factory wired to the condenser fan with 24 v coil for connection to indoor compressor unit.



5. Fan cycling (two-fan units only) shall include temperature actuated fan cycling switch, fan contactors, and low voltage terminal strip. Factory-mounted control cycles one fan in response to entering air-temperature to maintain head pressure.
6. Fan motor speed control shall be provided to allow operation to -20 F. Factory mounted controller modulates the speed of the lead condenser fan in response to discharge head pressure. Fan cycling control and contactors provided wired with controls. Control shall include all components of fan cycling control and a single-phase motor qualified for use with speed control and speed controller.
7. Totally Enclosed, Air Over (TEAO) condenser-fan motors shall be furnished for protection in harsh environments.
8. Final pass subcooling circuit shall be provided to allow additional cooling of refrigerant to compensate for long refrigerant line or applications with condenser below compressor.
9. Copper tube with copper fin or polyester or phenolic coated fins for corrosion protection.
10. Fused disconnect switch for 3-phase units.
11. Control transformer with 24 v output to operate condenser and/or compressor and evaporator.

Guide specifications — 09AZ

Air-Cooled Condensers

HVAC Guide Specifications

Size Range: **5 to 15 Tons**

Carrier Model Number: **09AZ**

Part 1 — General

1.01 SYSTEM DESCRIPTION

Outdoor mounted, packaged air-cooled remote condenser. Unit shall discharge condenser air vertically or horizontally as shown on contract drawings.

1.02 QUALITY ASSURANCE

- A. Units shall be rated using refrigerant R-22 or R-134a. Ratings shall be listed at a minimum (5 F subcooling) and optimum (15 F subcooling) refrigerant charge and in accordance with ARI Standard 460. Units shall be rated with 50BZN units of the same nominal size and listed in ARI directory.
- B. Unit shall be designed to conform to ANSI/ASHRAE 15, latest revision safety code, and UL Standard 1995, and shall be UL listed under both American and Canadian Standards.
- C. Coils shall be leak tested at 400 psig and unit operation shall be tested at the factory.

1.03 DELIVERY, STORAGE, AND HANDLING

Units shall be stored and handled according to manufacturer's recommendations.

Part 2 — Products

2.01 EQUIPMENT

A. General:

Outdoor mounted, packaged, air-cooled remote condenser. Factory-assembled unit shall consist of condenser coil, fan(s) and motor(s), mounting legs, factory wiring, piping and controls, and a charge of dry nitrogen.

B. Unit Cabinet:

1. Cabinet shall be constructed of minimum 18 gage corrosion resistant zinc coated galvanized steel and are capable of withstanding Federal method Standard No. 141 (Method 6061) 500-hour salt spray test. (Optional heavy gage embossed aluminum shall be available.)
2. Two-fan units shall be divided by full width baffles to separate individual fan sections and prevent air bypass and provide additional casing rigidity.
3. Uni sizes 10 ton and larger shall be furnished with lifting eyes to aid in rigging.
4. Panels for servicing shall be easily removable using a single wrench size.
5. Unit sizes 5 ton to 7½ ton shall have minimum 12 gage galvanized steel mounting legs, 15 in. high, and mounting rails. Legs shall be shipped with the unit for field assembly. Headers are to be arranged for horizontal or vertical airflow.
6. Unit sizes 10 ton to 15 ton shall have minimum 10 gage galvanized steel legs, 18 in. high, and 12 gage base rail.
7. Unit sizes 10 to 15 ton shall be factory arranged for vertical or horizontal airflow as required. Headers shall have proper arrangement and connection locations for correct refrigerant and oil return for the required airflow.

C. Fans:

Fans shall be propeller type, direct driven by weatherproof motors, and dynamically balanced. Discharge side shall be protected by corrosion-resistant fan guards constructed of vinyl coated close-mesh steel wire. Fans shall have dual square head set screws spaced 90 degrees apart which seat onto one flat and one keyway on the motor shaft.



D. Coils:

Coils shall use copper tubes, aluminum fin (or optional copper tube with copper fin, or be coated with polyester or phenolic fin treatment as required) and galvanized steel tube sheets. Fins shall be bonded to tubes by mechanical expansion. Hot gas and liquid connections shall be made from the same end. Coil circuiting shall be single, 5 and 7½ ton (100% capacity) or dual, 10 to 15 ton (50/50% capacity) circuit with a final pass subcooling circuit. Fins shall not exceed 14 fins per inch.

E. Motors:

Motors shall be weatherproof and inherently protected to operate at the specified electrical characteristics. Motor shall have permanently lubricated ball bearings. When required by environmental conditions, optional TEAO (Totally Enclosed, Air Over) motors shall be used. Motors shall be factory wired to weatherproof NEMA 3R control box on opposite header end of unit. Fan motors shall be a rigid base type mounted to 12 gage galvanized steel rails. When required by specifications low-sound motors shall be provided.

F. Operating Characteristics:

Unit shall be capable of rejecting the required heat at the required cfm and be capable of operating at moderate ambient temperatures with standard factory-supplied fan cycling and at reduced ambient temperatures with optional fan cycling or motor speed control.

G. Electrical Characteristics:

All electrical power wiring shall enter the unit cabinet at a single location. Fan motor contactors shall be provided and wired to condenser fans. Control circuit is 24 v and control wiring shall enter the unit control box at one connection only.

H. Special Features:

Units shall be furnished with optional factory mounted or field-installed special features (as required by application).

1. Embossed Aluminum cabinet shall be provided for enhanced appearance and corrosion protection.
2. Extended 30-in. mounting legs for unit sizes 10 ton and larger.
3. Low sound condenser-fan motors shall be furnished for lower condenser-fan sound applications.
4. Fan cycling (two-fan units only) shall include temperature actuated fan cycling switch, fan contactors, and low voltage terminal strip. Factory-mounted control cycles one fan in response to entering air-temperature to maintain head pressure.
5. Fan motor speed control shall be provided to allow operation to -20 F. Factory mounted controller modulates the speed of the lead condenser fan in response to discharge head pressure. Fan cycling control and contactors provided wired with controls. Control shall include all components of fan cycling control and a single-phase motor qualified for use with speed control and speed controller.
6. Totally Enclosed, Air Over (TEAO) condenser-fan motors shall be furnished for protection in harsh environments.
7. Final pass subcooling circuit shall be provided to allow additional cooling of refrigerant to compensate for long refrigerant line or applications with condenser below compressor.
8. Copper tube with copper fin or polyester or phenolic coated fins for corrosion protection.
9. Fused disconnect switch for 3 phase units.
10. Control transformer with 24 v output to operate condenser and/or compressor and evaporator.





Motores y ventiladores

1

Motores trifásicos

Tensión conmutable 220/440V. Arranque directo a 220V ó 440V. Arranque estrella-triángulo a partir del tipo 1LA5 130 tanto a 220V como a 440V. Ejecución B3, IP54, totalmente cerrados (TEFC). - IP55 para la serie 1LA7 y tamaños constructivos superiores al 250 M. **Los únicos aptos para ser accionados con Variador de Velocidad sin pérdida de potencia.**

Mar. 30/2000

No. Depósito	Descripción							Precio Lista Unit. - Bs (*)
								
			1LA7 071		1LA7 080			
	Tipo	Tamaño Constructivo	Potencia		FS	Corriente (A)		
			HP	KW		220V	440V	
	VELOCIDAD: 3.600 RPM (2 polos)							
836273	1LA7 070 - 2YA60	71	0.75	0.56	1.15	2.4	1.2	87.500
836290	1LA7 072 - 2YA60	71	0.9	0.67	1.05	3.2	1.6	91.100
836274	1LA7 073 - 2YA60	71	1.0	0.75	1.15	3.5	1.75	95.800
836201	1LA7 080 - 2YC60	80	1.2	0.90	1.05	4.0	2.0	99.900
836276	1LA7 080 - 2YA60	80	1.5	1.12	1.15	5.3	2.65	102.400
836202	1LA7 082 - 2YA60	80	1.8	1.34	1.05	5.8	2.9	107.200
836278	1LA7 083 - 2YA60	80	2.0	1.50	1.15	6.2	3.1	117.300
836203	1LA7 090 - 2YC60	90	2.4	1.79	1.05	7.0	3.5	141.900
836279	1LA7 090 - 2YA60	90	3.0	2.20	1.15	9.0	4.5	150.700
836204	1LA7 094 - 2YA60	90	3.6	2.70	1.05	10.6	5.3	166.800
836281	1LA7 096 - 2YA60	90	4.0	3.00	1.15	12.2	6.1	169.000
836206	1LA5 112 - 2YB60	112 M	5.0	3.73	1.15	16.0	8.0	209.200
836207	1LA5 113 - 2YB60	112 M	6.6	4.92	1.05	19.0	9.5	255.900
836283	1LA5 114 - 2YB60	112 M	7.5	5.60	1.15	21.8	10.9	287.200
836284	1LA5 131 - 2YB70	132 S/M	10	7.5	1.15	28.0	14.0	337.300
836212	1LA5 132 - 2YB70	132 S/M	12	9.0	1.05	32.0	16.0	386.000
836285	1LA5 133 - 2YB70	132 S/M	15	11.2	1.05	42.6	21.3	394.400
836286	1LA5 163 - 2YB70	160 M/L	20	14.9	1.05	53.0	26.5	592.300
836224	1LA5 164 - 2YB70	160 M/L	25	18.7	1.15	70.0	35.0	670.900
836230	1LA5 167 - 2YB70	160 M/L	30	22.4	1.05	81.0	40.5	850.000
	Motores de alta eficiencia (Eficiencias superiores a E-P Act.)							
856235	1LA4 183 - 2YC80	180 M	35	26.1	1.05	87	43.5	1'164.000
856242	1LA4 184 - 2YA80	180 L	40	29.8	1.05	102	51.0	1'662.300
856248	1LA4 206 - 2YC80	200 L	50	37.3	1.15	124	62.0	1'932.500
856250 ²⁾	1LA4 207 - 2YA80	200 L	60	44.5	1.15	148	74.0	2'144.200
856275 ²⁾	1LA6 224 - 2YC80	225 M	75	55.5	1.15	188	94.0	2'375.000
843275 ³⁾	1LA6 258 - 2BB90-Z	250 M	100	75	1.2	240	120.0	3'454.000
843210 ^{1) 3)}	1LA6 280 - 2AC60	280 S	125	93	1.0	-	143.6	4'665.000
843212 ^{1) 3)}	1LA6 283 - 2AC60	280 M	150	112	1.0	-	169.7	5'653.000
843218 ^{1) 3)}	1LA6 310 - 2AC60	315 S	185	138	1.0	-	212.3	6'812.000
843220 ^{1) 3)}	1LA6 313 - 2AC60	315 M	225	168	1.0	-	257.4	8'100.000
843225 ^{1) 3)}	1LA6 316 - 2AC60	315 L	275	205	1.0	-	309.9	10'273.000
843230 ^{1) 3)}	1LA6 317 - 2AC60	315 L	325	242	1.0	-	360.7	12'230.000
	Importante: Garantice la protección efectiva de su motor con el equipo de control Siemens que se encuentra en las páginas 3/2 a 3/10 de esta Lista de Precios.							
	Notas: - Motores hasta tamaño constructivo 225 en ejecución B5 tienen un sobreprecio del 10%.							
	¹⁾ Para tensión de servicio a 220 V, favor consultar.				³⁾ Consultar tiempo de entrega.			
	²⁾ Motores de fabricación bajo pedido.				^(*) El precio lista no incluye el IVA vigente.			
Cancela y sustituye a la página 1/2 de la lista con fecha Febrero 1/99 Precios sujetos a cambio sin previo aviso								

Motores Trifásicos

Tensión conmutable 220/440V. Arranque directo a 220V ó 440V. Arranque estrella-triángulo a partir del tipo 1LA5 130 tanto a 220V como a 440V. Ejecución B3, IP54, totalmente cerrados (TEFC). - IP55 para la serie 1LA7 y tamaños constructivos superiores al 250 M. **Los únicos aptos para ser accionados con Variador de Velocidad sin pérdida de potencia.**

Mar. 30/2000

**Nueva Serie
1LA7**



1LA7 090



1LA6 225

No. Depósito	Descripción							Precio Lista Unit. - Bs (*)
	Tipo	Tamaño Constructivo	Potencia		FS	Corriente (A)		
			HP	KW		220V	440V	
	VELOCIDAD: 1.800 RPM (4 polos)							
836440	1LA7 070 - 4YC60	71	0.4	0.29	1.05	1.6	0.80	77.800
836472	1LA7 070 - 4YA60	71	0.5	0.37	1.15	1.9	0.95	79.100
836460	1LA7 071 - 4YA60	71	0.6	0.45	1.05	2.2	1.10	82.600
836473	1LA7 073 - 4YA60	71	0.75	0.56	1.15	3.0	1.50	84.100
836490	1LA7 080 - 4YC60	80	0.9	0.67	1.05	3.1	1.55	87.800
836474	1LA7 080 - 4YA60	80	1.0	0.75	1.15	3.5	1.75	93.000
836401	1LA7 081 - 4YA60	80	1.2	0.90	1.05	4.0	2.00	97.100
836476	1LA7 083 - 4YA60	80	1.5	1.12	1.15	5.0	2.5	115.700
836402	1LA7 090 - 4YC60	90	1.8	1.34	1.05	6.4	3.2	139.500
836478	1LA7 090 - 4YA60	90	2.0	1.50	1.15	7.0	3.5	144.100
836479	1LA7 096 - 4YA60	90	3.0	2.20	1.15	9.6	4.8	177.600
836404	1LA5 111 - 4YB60	112 M	4.0	3.00	1.15	13.5	6.8	190.200
836406	1LA5 112 - 4YB60	112 M	5.0	3.73	1.15	17.0	8.5	213.300
836407	1LA5 113 - 4YB60	112 M	6.6	4.92	1.05	19.0	9.5	264.900
836483	1LA5 114 - 4YB60	112 M	7.5	5.60	1.15	23.2	11.6	280.900
836484	1LA5 131 - 4YB70	132 S/M	10	7.5	1.15	28.8	14.4	374.400
836412	1LA5 133 - 4YB70	132 S/M	12	9.0	1.05	34.0	17.0	394.000
836485	1LA5 134 - 4YB70	132 S/M	15	11.2	1.15	43.2	21.6	491.100
836486	1LA5 164 - 4YB70	160 M/L	20	14.9	1.15	53.0	26.5	606.400
836487	1LA5 167 - 4YC70	160 M/L	25	18.7	1.15	64.0	32.0	709.000
	Motores de alta eficiencia (Eficiencias superiores a E-P Act.)							
856431	1LA4 183 - 4YA80	180 M	30	22.4	1.05	78	39.0	1'052.000
856436	1LA4 186 - 4YA80	180 L	36	26.8	1.05	93	46.5	1'320.600
856440	1LA4 187 - 4YA80	180 L	40	29.8	1.05	104	52.0	1'511.200
856448	1LA4 207 - 4YC80	200 L	50	37.3	1.15	126	63.0	1'884.500
856450	1LA6 220 - 4YA80	225 S	60	44.5	1.15	148	74.0	2'130.800
856475	1LA6 224 - 4YC80	225 M	75	56.0	1.15	188	94.0	2'510.700
843475	1LA6 258 - 4BA90-Z	250 M	100	75	1.2	240	120.0	3'306.000
843410	1LA6 280 - 4BA90-Z	280 S	125	93	1.05	290	145.0	4'478.000
843412	1LA6 283 - 4BA90-Z	280 M	150	112	1.0	355	177.5	5'245.000
843418 ^{1) 3)}	1LA6 310 - 4AA60	315 S	185	138	1.0	-	222.2	6'343.000
843420 ^{1) 3)}	1LA6 313 - 4AA60	315 M	225	168	1.0	-	265.2	7'107.000
843425 ^{1) 3)}	1LA6 316 - 4AA60	315 L	275	205	1.0	-	323.1	8'703.000
843430 ^{1) 3)}	1LA6 317 - 4AA60	315 L	350	261	1.0	-	409.5	10'350.000
	Importante: Garantice la protección efectiva de su motor con el equipo de control Siemens que se encuentra en las páginas 3/2 a 3/10 de esta Lista de Precios.							
	Notas: - Motores hasta tamaño constructivo 225 en ejecución B5 tienen un sobreprecio del 10%.							
	¹⁾ Para tensión de servicio a 220 V, favor consultar.				³⁾ Consultar tiempo de entrega.			
	(*) El precio lista no incluye el IVA vigente.							
Cancela y sustituye a la página 1/3 de la lista con fecha Febrero 1/99 Precios sujetos a cambio sin previo aviso								

1

Motores trifásicos

Tensión conmutable 220/440V. Arranque directo a 220V ó 440V, en todos los tipos. Arranque estrella-triángulo a partir del tipo 1LA5 130 tanto a 220V como a 440V. Ejecución B3, IP54, totalmente cerrados (TEFC)-IP55 para la serie 1LA7 y tamaños constructivos superiores al 250M. **Los únicos aptos para ser accionados con Variador de Velocidad sin pérdida de potencia.** Mar. 30/2000

No. Depósito	Descripción							Precio Lista Unit. - Bs (*)
	Tipo	Tamaño Constructivo	Potencia HP	Potencia KW	FS	Corriente(A) 220V 440V		
VELOCIDAD: 1.200 RPM (6 polos)								
836640	1LA7 072 - 6YA60	71	0.4	0.29	1.05	1.6	0.80	97.900
836672	1LA7 073 - 6YA60	71	0.5	0.37	1.15	2.2	1.10	101.500
836660	1LA7 080 - 6YC60	80	0.6	0.45	1.05	2.4	1.20	104.700
836673	1LA7 080 - 6YA60	80	0.75	0.56	1.15	3.3	1.65	116.400
836690 ²⁾	1LA7 082 - 6YA60	80	0.9	0.66	1.05	3.2	1.60	129.100
836674	1LA7 083 - 6YA60	80	1.0	0.74	1.15	4.2	2.10	140.100
836601	1LA7 090 - 6YC60	90	1.2	0.90	1.05	5.2	2.60	153.700
836676	1LA7 090 - 6YA60	90	1.5	1.12	1.15	6.0	3.00	181.000
836678	1LA7 096 - 6YA60	90	2.0	1.50	1.15	7.8	3.90	187.900
836679	1LA5 112 - 6YB60	112 M	3.0	2.20	1.15	11.8	5.90	219.900
836681	1LA5 113 - 6YB60	112 M	4.0	3.00	1.15	15.0	7.50	281.600
836606	1LA5 130 - 6YB70	132 S/M	5.0	3.73	1.05	16.4	8.20	376.500
836683	1LA5 133 - 6YB70	132 S/M	7.5	5.60	1.15	25.0	12.5	423.900
836684	1LA5 135 - 6YB70	132 S/M	10	7.5	1.15	37	18.5	555.000
836612	1LA5 163 - 6YB70	160 M/L	12	9.0	1.05	38	19	606.100
836685	1LA5 164 - 6YB70	160 M/L	15	11.2	1.05	44	22	901.000
836686	1LA5 167 - 6YC70	160 M/L	20	14.9	1.05	60	30	1'020.000
Motores de alta eficiencia (Eficiencias superiores a E-P Act.)								
856624 ²⁾	1LA4 186 - 6YA80	180 L	25	18.7	1.05	67.5	33.8	1'326.400
856625 ²⁾	1LA4 206 - 6YA80	200 L	30	22.4	1.05	79.0	39.5	1'920.200
856630 ²⁾	1LA4 207 - 6YA80	200 L	36	26.8	1.05	95.0	47.5	2'170.300
856650 ²⁾	1LA6 223 - 6YC80	225 M	50	37.3	1.15	124.0	62.0	2'611.900
843606 ¹⁾³⁾	1LA6 253 - 6AA60	250 M	60	45	1.10	-	73.9	3'454.000
843608 ¹⁾³⁾	1LA6 280 - 6AA60	280 S	75	56	1.05	-	91.7	4'190.000
843609 ¹⁾³⁾	1LA6 283 - 6AA60	280 M	100	75	1.00	-	121.7	5'025.000
843610 ¹⁾³⁾	1LA6 310 - 6AA60	315 S	125	93	1.05	-	151.6	6'596.000
843612 ¹⁾³⁾	1LA6 313 - 6AA60	315 M	150	112	1.05	-	181.3	7'800.000
843618 ¹⁾³⁾	1LA6 316 - 6AA60	315 L	175	131	1.05	-	210.4	9'215.000
843620 ¹⁾³⁾	1LA6 317 - 6AA60	315 L	200	149	1.10	-	239.7	11'060.000
843625 ¹⁾³⁾	1LA6 318 - 6AA60	315 L	250	187	1.05	-	299.3	13'180.000
<p>Importante: Garantice la protección efectiva de su motor con el equipo de control Siemens que se encuentra en las páginas 3/2 a 3/10 de esta Lista de Precios.</p> <p>Notas: - Motores hasta tamaño constructivo 225 en ejecución B5 tienen un sobreprecio del 10%. - Para otras potencias y/o velocidades, favor consultar.</p> <p>¹⁾ Para tensión de servicio a 220 V, favor consultar. ³⁾ Consultar tiempo de entrega. ²⁾ Motores de fabricación bajo pedido. (*) El precio lista no incluye el IVA vigente.</p>								
<p>Cancela y sustituye a la página 1/4 de la lista con fecha Febrero 1/99 Precios sujetos a cambio sin previo aviso</p>								



Motores monofásicos semiabiertos IP23 (ODP)

Tensión conmutable 115/230V, 60 Hz.

Con condensador de arranque (alto par de arranque).

Factor de Servicio (FS) y características según norma NEMA.

Mar. 30/2000

No. Depósito	Descripción					Precio Lista Unit. - Bs (*)
						
	Ejecución NEMA 56 J		Ejecución B3			
	Tipo	Potencia HP	FS	Corriente con FS (A)		
				115V	230V	
	Ejecución Jet Pump NEMA 56 J - 3.600 rpm (2 polos)					
887203	1RF3 092 - 2YB99	1/3	1.75	8.6	4.3	89.600
887205	1RF3 093 - 2YB99	1/2	1.60	10.4	5.2	93.900
887207	1RF3 094 - 2YB99	3/4	1.50	13.6	6.8	103.900
887210	1RF3 095 - 2YB99	1.0	1.40	16.3	8.2	117.800
887215	1RF3 096 - 2YB99	1.5	1.30	22.0	11.0	129.700
887220	1RF3 097 - 2YB99	2.0	1.20	25.0	12.5	153.400
887230	1RF3 098 - 2YB99	3.0	1.15	35.0	17.5	186.800
	Ejecución B3 - 3.600 rpm (2 polos)					
889203	1RF3 092 - 2YB90	1/3	1.75	8.6	4.3	89.400
889205	1RF3 093 - 2YB90	1/2	1.60	10.4	5.2	90.000
889207	1RF3 094 - 2YB90	3/4	1.50	13.6	6.8	99.700
889210	1RF3 095 - 2YB90	1.0	1.40	16.3	8.2	113.600
889215	1RF3 096 - 2YB90	1.5	1.30	22.0	11.0	125.200
889220	1RF3 097 - 2YB90	2.0	1.20	25.0	12.5	143.300
889230	1RF3 098 - 2YB90	3.0	1.15	35.0	17.5	179.000
	Ejecución B3 - 1.800 rpm (4 polos)					
887403	1RF3 092 - 4YD90	1/3	1.35	7.0	3.5	90.100
887405	1RF3 093 - 4YD90	1/2	1.25	9.0	4.5	96.200
887407	1RF3 094 - 4YD90	3/4	1.25	13.6	6.8	115.200
887410	1RF3 095 - 4YD90	1.0	1.15	16.2	8.1	121.100
887415	1RF3 096 - 4YD90	1.5	1.15	22.8	11.4	145.600
887420	1RF3 097 - 4YD90	2.0	1.15	27.6	13.8	166.000
885430	1LF3 112 - 4YD90	3.0	1.15	37.0	18.5	282.300
	Notas: (*) El precio lista no incluye el IVA vigente.					
Cancela y sustituye a la página 1/6 de la lista con fecha Febrero 1/99 Precios sujetos a cambio sin previo aviso						

1

Repuestos para motores trifásicos

Mar. 30/2000

No. Depósito	Descripción			Precio Lista Unit. - Bs (*)
	Platillo de cojinete AS/B5 (11.0)			
897040	Para motor tamaño constructivo	071	(1LA7)	21.500
890040		071	(1LA3)	24.800
897041		080	(1LA7)	25.800
890041		080	(1LA3)	28.900
897042		090	(1LA7)	37.900
890042		090 S/L	(1LA3)	43.100
890043		100 L		50.500
895044		112 M	(1LA5)	61.300
890044		112 M	(1LA3)	68.700
895045		132 S/M	(1LA5)	82.900
890045		132 S/M	(1LA3)	88.600
890046		160 M/L		140.600
890047		180 M/L	(1LA4)	142.500
896047		180 M/L	(1LA6)	142.500
890048		200 L		144.300
R891049		225 S/M		151.600
	Ventiladores (51.3)			
897001	Para motor tamaño constructivo	071	(1LA7, 1LA3)	5.100
897002		080	(1LA7, 1LA3)	5.500
897003		090	(1LA7)	5.900
890003		090 S/L	(1LA3)	6.100
890004		100 L/112 M	(1LA3)	7.100
895004		112 M	(1LA5)	7.100
890005		132 S/M	(1LA3)	8.200
895005		132 S/M	(1LA5)	8.200
890009		160 M/L	2 polos	9.500
890010		160 M/L	4/6 polos	9.500
R891011		180 M/L	(1LA4, 1LA6) 2 polos	57.000
R891012		180 M/L	(1LA4, 1LA6) 4/6 polos	62.400
R891013		200 L, 225 M	2 polos	62.300
R891014		200 L, 225 S/M	4/6 polos	63.100
	Caperuza (52)			
R898001	Para motor tamaño constructivo	071	(1LA7)	15.200
R891001		071	(1LA3)	15.800
R898002		080	(1LA7)	17.100
R891002		080	(1LA3)	17.800
R898003		090	(1LA7)	20.200
R891003		090 S/L	(1LA3)	21.300
R891004		100 L		22.200
R891005		112 M	(1LA3, 1LA5)	23.500
R891006		132 S/M	(1LA3, 1LA5)	30.600
R891007		160 M/L	(1LA3, 1LA5)	35.600
R891008		180 M/L	(1LA4)	37.300
R891008		180 M/L	(1LA6)	37.300
R891009		200 L		42.400
R891010		225 S/M		46.200
	Regleta de bornes (66.5)			
897025	Para motor tamaño constructivo	71/80/90 (1LA7)	Tipo GK 030	7.900
890020		71/80 (1LA3)	GK 010	8.100
890025		090 S/L, 100L, 112M (1LA3, 1LA5)	GK 130	11.600
890026		132 S/M (1LA3, 1LA5)	GK 239	22.200
890027		160 M/L (1LA3, 1LA5)	GK 339	28.500
890028		180 M/L (1LA4, 1LA6); 225 S/M		37.900
	(La regleta completa consta de 4 borneras)			
Notas: (*) El precio lista no incluye el IVA vigente.				
Cancela y sustituye a la página 1/7 de la lista con fecha Febrero 1/99				
Precios sujetos a cambio sin previo aviso				

Repuestos para motores monofásicos

Mar. 30/2000

No. Depósito	Descripción	Precio Lista Unit. - Bs (*)
891060	Platillo de cojinetes AS/NEMA 56 J (11.0) Para motor 1RF3	18.100
891061	Platillo de cojinetes AS/B3 (11.1) Para motor 1RF3	16.900
891062	Platillo de cojinetes BS (41.1) Para motor 1RF3	14.800
890063	Interruptor centrífugo en herradura (40.1 - 40.2) Parte móvil, para motor de 3.600 rpm	8.500
890064	Parte móvil, para motor de 1.800 rpm	10.000
890065	Portacontacto - parte fija, para 3.600 y 1.800 rpm	9.900
891086	Ventiladores (50.1) Para motor 1RF3	4.200

Notas: (*) El precio lista no incluye el IVA vigente.

Cancela y sustituye a la página 1/8 de la lista con fecha Febrero 1/99
Precios sujetos a cambio sin previo aviso



1

Ventiladores axiales industriales

Repuestos para ventiladores

Con elevado caudal de aire.

Mar. 30/2000

No. Depósito	Descripción					Precio Lista Unit. - Bs (*)	
							
	Con motor monofásico		Con motor trifásico				
	Tipo	Diámetro (mm.)	Caudal (m3/s)	Potencia (kW)	Corriente (A)		
	1. Con motores monofásicos 110V, 1.800 rpm¹⁾						
821425	2CC2 254 - 5YC3	250	0.38	0.05	0.8	112.600	
821430	2CC2 314 - 5YC3	310	0.70	0.08	1.5	116.100	
821435	2CC2 354 - 5YC3	350	1.01	0.11	1.9	119.700	
821440	2CC2 404 - 5YC3	400	1.45	0.22	3.2	130.500	
821450	2CC2 504 - 5YA3	500	2.93	0.70	8.3	242.300	
	2. Con motores trifásicos 220/440V, 1.800 rpm¹⁾						
					220V	440V	
823440	2CC2 404 - 5YD6	400	1.45	0.20	1.14	0.57	116.000
823450	2CC2 504 - 5YB6	500	2.93	0.66	3.0	1.5	236.200
823460	2CC2 634 - 5YB6	630	5.33	1.60	6.4	3.2	332.600
823470	2CC1 714 - 5YB6	710	8.37	3.58	14.0	7.0	491.200
	3. Con motores trifásicos 220/440V, 1.200 rpm¹⁾						
823650	2CC2 506 - 5YB6	500	1.91	0.19	1.22	0.61	241.900
823660	2CC2 636 - 5YB6	630	3.55	0.51	3.1	1.55	273.800
823670	2CC2 716 - 5YB6	710	5.27	1.20	6.7	3.35	370.200
	<p>Importante: Asegure la protección efectiva de su ventilador con guardamotores 3RV (ver página 3/6).</p> <p>Notas: - ¹⁾ Los tipos 2CC2... vienen con aspa plástica y el tipo 2CC1... con aspa de aluminio. (*) El precio lista no incluye el IVA vigente.</p>						
<p>Cancela y sustituye a la página 1/9 de la lista con fecha Febrero 1/99 Precios sujetos a cambio sin previo aviso</p>							

1

Servicio Post-venta para motores eléctricos

Talleres de servicio autorizado

Caracas

Electro / Embobinado Galicia SR L
Calle Sánchez, Edf. Alda, Local PB
Santa Rosa con Andrés Bello
☎ (02) 573 2945
Fax. (02) 577 0281
Sr. Gilberth Fernández

Talleres JRIF, C.A.

Las Mayas, Sector Turmerito,
Kilómetro 1, Vía La Mariposa
☎ (02) 682 4210 - 682 4205
Fax. (02) 682 4281
Sr. José Ramiro Iglesias Fernández

Maracay

Electro Técnica Industrial
Calle Mariño Sur No.173, ETIL - VC
☎ (043) 467 853 - 469 955
Fax. (043) 463 267
Sr. Giovanni Tedoldi

Valencia

Sidelca - Servicios Industriales de
Electricidad, C.A.
Av. Circunvalación, Galpón No.114,
Zona Industrial La Quizanda
☎ (041) 345 754 - 345 775 - 345 886
Fax. (041) 343 530
Sr. Mario Melone

Zulia

Rimes, C.A.
Av. Intercomunal, Ed. "Rimes",
Ciudad Ojeda
☎ (065) 411 763 - 411 579 - 411 826
Fax. (065) 413 261
Sr. Mario Lanaro

El Tigre

Sertesa
Av. Fco. de Miranda No.301
☎ (088) 410 989 - 411 423
Fax. (088) 410 964
Sr. Tomás Iturregui

Oficinas de Siemens

Caracas

Av. Don diego Cisneros, Urbanización
Los Ruices,
Edificio Siemens,
Caracas 1010-A
☎ 3616
☎ (582) 203 8216 - 203 8116
Fax. (582) 203 8912
E-mail: a&d@siemens.com.ve

Valencia

Av. Norte Sur 5,
Zona Industrial Municipal Norte,
Edificio Siemens
☎ 455
☎ (5841) 342 482 - 334 211 - 344 208
Fax. (5841) 326 602 - 334 518

Maracaibo

Av.17 Los Haticos, No. 112-224,
Edificio Siemens
☎ 1089
☎ (5861) 651 338 - 651 832
Fax. (5861) 652 738 - 651 832

Puerto Ordaz

Carrera Ciudad Piar,
Edificio Uyapar, Piso 1
☎ 8015
☎ (5886) 230 306 - 225097
Fax. (5886) 230 031

Puerto La Cruz

Av. Intercomunal, Sector Las Garzas,
C.C. Sal Bahía, Locales 9 y 10,
Barcelona, Edo. Anzoátegui,
☎ (5881) 868 922 - 862 833 - 863 322
Fax. (5881) 868 544

Distribuidores mayoristas de productos y repuestos

Caracas

El Mundo del Motor Eléctrico, C.A.
Avenida Principal de Maripérez
entre 7ª y 8ª transversal, Quinta Tania.
☎ (02) 7930537 - 7933647
Fax. (02) 7812825

Servieleca - Servicios y Suministros Eléctricos, CA.

Centro Los Cortijos, Piso 1, Local 15/
Piso 2, Local 25
Av. Ppal. Los Cortijos de Lourdes.
☎ (02) 2380417 - 2382892
Fax. (02) 2399815

Talleres Ummon

Av. Rómulo Gallegos, Centro Industrial,
Local 3 - Boleita
☎ (02) 2352340 - 2347525
Fax. (02) 2397830

Distribuidora Luz y Control, C.A.

Av. Tamanaco, Res. Mónica, Local 1,
P.B. Urb. El Llanito
☎ (02) 2574239 - 2575896
Fax. (02) 2573859

Eléctrica Einoder

Calle 3-A. Oficina G, Edificio Centro
Profesional La Urbina, Piso 1
☎ (02) 2425191 - 2422781
Fax. (02) 2410192

Maracay

Electro Técnica Industrial

Calle Mariño Sur No.173, ETIL - VC
☎ (043) 467853 - 469955
Fax. (043) 463267

Instalaciones y Repuestos Salame, C.A.

Calle Mariño Sur, No. 76 B
☎ (043) 463815
Fax. (043) 463815

Saer de Venezuela

Calle Carabobo Sur No. 73, Santa Rosa
☎ (043) 510608 - 531646
Fax. (043) 514674

Cagua

La Instaladora Eléctrica

Calle Ayacucho Norte Centro 104,
No. 6023
☎ (044) 72897 - 78498
Fax. (044) 70178

Valencia

Dielesa

Centro Comercial "Arpe", nave D,
Locales 2 y 3
Avenida Pancho Pepe Croquer - Frente
a Jeep de Venezuela
☎ (041) 337137 - 322557
Fax. (041) 324555

Import - Import

Urb. Industrial Castillito, Av. 101,
C.C. Ligiana, Local 2
☎ (041) 716401 - 715907
Fax. (041) 718496

Motores y Protecciones

Big Low Center, Nave D, Local 39
☎ (041) 715523 - 714753
Fax. (041) 718229

Euromotores

Urb. Ind. Carabobo, Prolongación Av.
Michelena
☎ (041) 325074 - 320594
Fax. (041) 338692

Tivalca

Prolongación Av. Michelena,
C.C. Thema, No. 14
☎ (041) 325506 - 324496
Fax. (041) 322760

Maracaibo

Maelca - Materiales Eléctricos Perijá C.A.

Calle 85 (Falcón) con Av. 14A,
Locales 4 y 5
☎ (061) 973841 - 970092
Fax. (061) 979745

Marelca

Calle 100, Sabaneta N - 19E - 120
Residencias Paul II, Local 4
☎ (061) 237019 - 234556
Fax. (061) 234481

Barquisimeto

Sitca - Servicios de Ingeniería y Tecnología, C.A.

C. Ind. Libertador, Local 1-A, Avenida
☎ (051) 370583
Fax. (051) 373434

Pto. Ordaz

Sumicaba

Zona Ind. UD 321, Parc. 11-18, Calle 8,
Transv. H, Ed. Luedi PB
☎ (086) 942904
Fax. (086) 942777

Sicontrol

Carrera El Palmar, Edif. Maggiolo,
Piso 2, Oficina 5
☎ (086) 237484 / 016 - 6861729
Fax. (086) 237484

Sumeca - Suministros de Materiales Eléctricos, C.A.

Prolongación Av. Las Américas
☎ (086) 226621 - 222232
Fax. (086) 220466

Guanare

Emeica

Av. Unda con carrera 6
☎ (057) 511516 - 516620
Fax. (057) 514947

Pto. La Cruz

Siemelca

Calle Cementerio, Edif. Los Angeles,
Local 3
☎ (081) 688915 - 673648

Barinas

Teca - Talleres Electromecánicos, C.A.

Av. Industrial No. 1-135
☎ (073) 24058
Fax. (073) 335462

Guatire

Representaciones Insein, C.A.

Carretera Nacional Guarenas - Guatire,
C.C. El Refugio PB, Local PL - 02
☎ (02) 3810227
Fax. (02) 3811439
Ing. Ignacio Colangelo

Punto Fijo

Dica, C.A.

Edif. Dica, Avenida Girardot, Esq. con
calle Tuharusa
☎ (069) 468967 - 466498
Fax. (069) 468333

n [1/min]		700		950		1200		1450		1600		1750	
V _{th} [m ³ /h]		9,79		13,28		16,78		20,27		22,37		24,46	
to	tc	Q̇ _o	Pe	Q̇ _o	Pe	Q̇ _o	Pe	Q̇ _o	Pe	Q̇ _o	Pe	Q̇ _o	Pe
[°C]	[°C]	[kW]	[kW]	[kW]	[kW]	[kW]	[kW]	[kW]	[kW]	[kW]	[kW]	[kW]	[kW]
15	30	10,19	1,39	14,18	1,90	17,89	2,40	21,40	2,89	23,43	3,19	25,40	3,48
10		8,63	1,27	11,96	1,73	15,08	2,18	18,03	2,63	19,75	2,90	21,42	3,16
5		7,25	1,15	10,01	1,57	12,60	1,98	15,08	2,39	16,52	2,63	17,93	2,87
0		6,04	1,04	8,30	1,42	10,44	1,80	12,49	2,17	13,69	2,39	14,87	2,60
-5		4,99	0,94	6,82	1,28	8,56	1,62	10,25	1,95	11,24	2,15	12,21	2,35
-10		4,06	0,84	5,54	1,15	6,95	1,45	8,32	1,75	9,13	1,93	9,92	2,11
-15		3,26	0,75	4,45	1,02	5,58	1,29	6,68	1,56	7,33	1,71	7,97	1,87
-20		2,57	0,65	3,52	0,89	4,42	1,13	5,29	1,36	5,80	1,50	6,31	1,64
-25		1,97	0,56	2,74	0,76	3,46	0,96	4,14	1,16	4,53	1,28	4,91	1,40
-30		1,45	0,46	2,10	0,63	2,67	0,79	3,19	0,96	3,48	1,05	3,76	1,15
15	40	9,35	1,61	12,80	2,20	16,10	2,77	19,29	3,35	21,16	3,69	23,00	4,02
10		7,94	1,48	10,75	2,03	13,49	2,56	16,17	3,09	17,75	3,40	19,32	3,71
5		6,69	1,37	8,95	1,87	11,20	2,36	13,43	2,84	14,76	3,13	16,09	3,42
0		5,59	1,26	7,38	1,71	9,20	2,17	11,04	2,61	12,15	2,88	13,27	3,14
-5		4,63	1,15	6,02	1,57	7,47	1,98	8,97	2,39	9,88	2,63	10,82	2,87
-10		3,78	1,05	4,84	1,43	5,98	1,80	7,19	2,17	7,94	2,39	8,70	2,61
-15		3,05	0,94	3,84	1,28	4,72	1,62	5,68	1,96	6,28	2,15	6,90	2,35
-20		2,40	0,83	2,99	1,14	3,66	1,44	4,41	1,73	4,88	1,91	5,37	2,09
-25		1,84	0,72	2,28	0,99	2,79	1,25	3,35	1,50	3,71	1,66	4,09	1,81
-30		1,35	0,61	1,69	0,83	2,07	1,04	2,49	1,26	2,76	1,39	3,03	1,51
15	50	8,27	1,80	11,17	2,45	14,02	3,10	16,83	3,74	18,51	4,12	20,17	4,49
10		7,04	1,67	9,34	2,28	11,66	2,89	14,01	3,48	15,43	3,83	16,86	4,19
5		5,95	1,56	7,72	2,12	9,60	2,68	11,54	3,23	12,74	3,56	13,95	3,89
0		4,99	1,44	6,32	1,97	7,80	2,48	9,39	2,99	10,39	3,30	11,41	3,60
-5		4,13	1,33	5,10	1,81	6,24	2,29	7,53	2,76	8,35	3,04	9,21	3,32
-10		3,39	1,21	4,05	1,66	4,91	2,09	5,93	2,52	6,60	2,78	7,31	3,04
-15		2,73	1,10	3,15	1,50	3,79	1,89	4,58	2,28	5,12	2,51	5,70	2,74
-20		2,15	0,98	2,40	1,33	2,85	1,68	3,45	2,03	3,87	2,23	4,33	2,44
-25		1,63	0,85	1,77	1,15	2,08	1,46	2,52	1,76	2,84	1,94	3,19	2,11
-30		1,17	0,70	1,25	0,96	1,46	1,21	1,78	1,46	2,00	1,61	2,26	1,76
15	60	6,92	1,95	9,26	2,66	11,62	3,36	13,99	4,06	15,42	4,47	16,85	4,88
10		5,90	1,83	7,68	2,50	9,57	3,15	11,54	3,80	12,75	4,19	13,99	4,57
5		5,00	1,71	6,30	2,33	7,78	2,95	9,39	3,55	10,41	3,91	11,47	4,27
0		4,20	1,59	5,09	2,17	6,22	2,74	7,52	3,30	8,38	3,64	9,27	3,97
-5		3,49	1,47	4,04	2,00	4,87	2,53	5,91	3,05	6,62	3,36	7,37	3,67
-10		2,85	1,34	3,14	1,83	3,73	2,32	4,54	2,79	5,11	3,08	5,74	3,36
-15		2,29	1,21	2,38	1,66	2,77	2,09	3,38	2,52	3,84	2,78	4,35	3,03
-20		1,78	1,07	1,74	1,46	1,98	1,85	2,42	2,23	2,77	2,46	3,18	2,68
-25		1,32	0,92	1,21	1,25	1,33	1,58	1,65	1,91	1,90	2,10	2,21	2,30
-30		0,90	0,75	0,77	1,02	0,83	1,29	1,03	1,55	1,21	1,71	1,41	1,87
15	70	5,25	2,06	7,03	2,82	8,86	3,56	10,71	4,29	11,84	4,73	12,98	5,16
10		4,50	1,94	5,76	2,65	7,17	3,35	8,70	4,04	9,65	4,45	10,64	4,86
5		3,82	1,82	4,64	2,49	5,70	3,14	6,93	3,79	7,74	4,17	8,59	4,56
0		3,21	1,70	3,67	2,32	4,43	2,93	5,41	3,53	6,08	3,89	6,81	4,24
-5		2,66	1,57	2,83	2,14	3,34	2,70	4,10	3,26	4,65	3,59	5,26	3,92
-10		2,17	1,43	2,12	1,95	2,42	2,46	2,99	2,97	3,43	3,27	3,94	3,58
-15		1,71	1,28	1,51	1,75	1,66	2,21	2,06	2,66	2,41	2,93	2,82	3,20
-20		1,30	1,12	1,00	1,53	1,04	1,93	1,31	2,33	1,57	2,56	1,89	2,80
-25		0,91	0,94	0,59	1,28	0,55	1,62	0,71	1,95	0,89	2,15	1,12	2,34
-30		0,53	0,73	0,26	1,00	0,18	1,26	0,26	1,52	0,36	1,67	0,50	1,83

Die Kälteleistungen gelten

- bei 25 °C Sauggasttemperatur
- ohne Flüssigkeitsunterkühlung

Q̇_o = Kälteleistung

Pe = Leistungsbedarf

to = Verdampfungstemperatur

tc = Verflüssigungstemperatur

V_{th} = Theoretisches Hubvolumen

n = Verdichter-Drehzahl

☐ = Sauggasüberhitzung kleiner als 20K oder Zusatzkühlung erforderlich

The refrigerating capacities are valid

- at a suction gas temperature of 25 °C
- without liquid subcooling

Q̇_o = Refrigerating capacity

Pe = Power input

to = Evaporation temperature

tc = Condensing temperature

V_{th} = Theoretical displacement

n = Compressor speed

☐ = Suction gas temperature less than 20K or additional cooling required

Les puissance frigorifiques sont valables

- à une température d'aspiration de 25 °C
- sans sousrefroidissement de liquide

Q̇_o = Puissance frigorifique

Pe = Puissance absorbée

to = Température d'évaporation

tc = Température de condensation

V_{th} = Volume déplacé théorique

n = Nombre de tours du compresseur

☐ = Température de gaz aspiration moins 20K ou refroidissement additionnel nécessaire

n [1/min]		700		950		1200		1450		1750	
V _{th} [m ³ /h]		9,79		13,28		16,78		20,27		24,47	
t _o [°C]	t _c [°C]	Q _o [kW]	Pe [kW]	Q _o [kW]	Pe [kW]	Q _o [kW]	Pe [kW]	Q _o [kW]	Pe [kW]	Q _o [kW]	Pe [kW]
10	30	12,20	1,81	17,00	2,46	21,30	3,12	25,40	3,77	29,90	4,56
5		10,40	1,67	14,40	2,27	18,10	2,87	21,50	3,47	25,40	4,19
0		8,75	1,54	12,10	2,10	15,20	2,65	18,00	3,20	21,30	3,85
-5		7,32	1,42	10,10	1,94	12,60	2,44	15,00	2,94	17,70	3,53
-10		6,06	1,30	8,29	1,78	10,40	2,25	12,30	2,70	14,60	3,24
-15		4,96	1,20	6,75	1,64	8,42	2,06	10,00	2,48	11,80	2,96
-20		4,01	1,09	5,42	1,50	6,75	1,89	8,02	2,26	9,49	2,70
-25		3,20	0,99	4,29	1,36	5,32	1,71	6,32	2,05	7,48	2,45
-30		2,51	0,89	3,33	1,22	4,13	1,54	4,89	1,84	5,79	2,20
-35		1,92	0,79	2,54	1,08	3,14	1,36	3,72	1,63	4,39	1,94
-40		1,44	0,68	1,90	0,94	2,34	1,18	2,76	1,41	3,25	1,68
-45		1,05	0,57	1,40	0,78	1,72	0,98	2,02	1,18	2,36	1,40
10	40	11,10	2,07	15,50	2,83	19,50	3,59	23,20	4,33	27,40	5,23
5		9,39	1,91	13,10	2,61	16,50	3,30	19,60	3,98	23,20	4,80
0		7,91	1,75	11,00	2,40	13,80	3,03	16,40	3,66	19,40	4,40
-5		6,60	1,61	9,10	2,20	11,40	2,78	13,60	3,35	16,10	4,02
-10		5,45	1,47	7,47	2,02	9,35	2,55	11,10	3,06	13,20	3,68
-15		4,45	1,34	6,05	1,84	7,55	2,32	8,98	2,79	10,60	3,35
-20		3,59	1,22	4,83	1,67	6,01	2,11	7,15	2,53	8,46	3,03
-25		2,84	1,10	3,80	1,50	4,71	1,89	5,59	2,27	6,62	2,72
-30		2,21	0,97	2,93	1,33	3,62	1,68	4,30	2,02	5,09	2,41
-35		1,69	0,85	2,22	1,16	2,74	1,46	3,24	1,75	3,83	2,10
-40		1,25	0,71	1,65	0,97	2,03	1,23	2,40	1,48	2,82	1,78
-45		0,90	0,57	1,22	0,78	1,50	0,98	1,76	1,18	2,05	1,43
10	50	9,73	2,35	13,80	3,22	17,40	4,08	20,80	4,93	24,50	5,94
5		8,25	2,15	11,60	2,95	14,70	3,74	17,50	4,51	20,60	5,43
0		6,93	1,97	9,69	2,70	12,20	3,42	14,60	4,12	17,20	4,96
-5		5,77	1,80	8,00	2,46	10,10	3,12	12,00	3,76	14,20	4,51
-10		4,75	1,63	6,54	2,24	8,20	2,83	9,77	3,41	11,60	4,10
-15		3,86	1,48	5,26	2,03	6,58	2,56	7,84	3,08	9,28	3,70
-20		3,09	1,33	4,18	1,82	5,21	2,30	6,19	2,77	7,34	3,32
-25		2,44	1,18	3,26	1,61	4,05	2,04	4,81	2,45	5,70	2,95
-30		1,88	1,03	2,50	1,40	3,10	1,77	3,67	2,14	4,34	2,57
-35		1,42	0,87	1,89	1,19	2,33	1,50	2,76	1,82	3,25	2,19
-40		1,05	0,71	1,41	0,96	1,74	1,22	2,05	1,48	2,40	1,79
-45		0,75	0,53	1,06	0,71	1,32	0,91	1,54	1,11	1,78	1,36
10	60	8,17	2,64	11,80	3,63	15,00	4,60	17,90	5,56	21,10	6,69
5		6,90	2,41	9,88	3,31	12,60	4,19	15,00	5,06	17,70	6,08
0		5,78	2,19	8,21	3,01	10,40	3,81	12,40	4,60	14,70	5,52
-5		4,79	1,98	6,75	2,72	8,53	3,45	10,20	4,16	12,00	5,00
-10		3,92	1,79	5,48	2,46	6,90	3,11	8,24	3,75	9,75	4,50
-15		3,17	1,60	4,38	2,20	5,50	2,78	6,56	3,35	7,77	4,03
-20		2,52	1,42	3,45	1,95	4,32	2,46	5,14	2,97	6,09	3,57



Die Kälteleistungen gelten

- bei 25 °C Saugdampftemperatur
- ohne Flüssigkeitsunterkühlung
- Q_o = Kälteleistung
- Pe = Leistungsbedarf
- t_o = Verdampfungstemperatur
- t_c = Verflüssigungstemperatur
- V_{th} = Theoretisches Hubvolumen
- n = Verdichter-Drehzahl
- ☐ = Zusatzkühlung notwendig

The refrigerating capacities are valid

- at a suction gas temperature of 25 °C
- without liquid subcooling
- Q_o = Refrigerating capacity
- Pe = Power input
- t_o = Evaporation temperature
- t_c = Condensing temperature
- V_{th} = Theoretical displacement
- n = Compressor speed
- ☐ = Supplementary cooling necessary

Les puissances frigorifiques sont valables

- à une température d'aspiration de 25 °C
- sans sousrefroidissement de liquide
- Q_o = Puissance frigorifique
- Pe = Puissance absorbée
- t_o = Température d'évaporation
- t_c = Température de condensation
- V_{th} = Volume déplacé théorique
- n = Nombre de tours du compresseur
- ☐ = Refroidissement supplémentaire nécessaire

